



POWELL AGRICULTURAL SOLUTIONS ENGINEERING BRIEF

ISO 11783-2 Connectors for Modern Agricultural Technology

For more information:
aginfo@powell.com
856-241-5622



TABLE OF CONTENTS

- IBBC - ISOBUS Breakaway Connector 2.0
- IBBC-TP - Cost Optimized Twisted Pair IBBC
- IBIC™ ISOBUS Implement Connector
- IBIC™ Accessories
- IBIC-R™ Agricultural Inline Receptacle
- IBRC-3L - Three Latch Rear Connector
- TBC - Terminating Bias Circuit
- PAPIL4C Power Connectors
- OICC - ISOBUS Relay
- ISOBUS Jacketed Cables
- PAS HSI Gb Ethernet Switch
- PAS Dual Beam Radar
- Appendix: Technical Diagrams

The future of agriculture is smart farming performed with machines that support precision agriculture functions. This concept refers to modern farms using technology to reduce costs, gain higher yields and minimize environmental impact. Critical advancements in agricultural equipment have made it possible for farms to track crop life with great precision.

The utilization of IoT in agriculture is now the norm. Cameras and sensors are automatically used to monitor critical parameters such as soil nutrition, temperature, moisture, and more. Powell Agricultural Solutions focuses on the complex systems involved including connectivity, sensor fusion, position monitoring, telematics, and object identification. Integrated equipment is used to optimize crop potential by ensuring that the correct amount of seed, water, pesticide, and fertilizer are monitored and applied to the crops electronically via GPS. This new way of farming is accomplished with the help of monitors, sensors, and cross-brand computerized systems.

Powell Electronics provides components for Gb Ethernet, ISO 11783-2 and SAE J1939 applications. Over 70 years in electronics history with a vast array of related products such as ground radar, switches, connectors, lighting, circuit breakers, solenoids and value-added assemblies. Thank you for your interest in Powell Agricultural Solutions, and we look forward to engineering a solution for you.

Powell Agricultural Solutions provides all equipment makers the most advanced ISO 11783-2 connectors for the most demanding applications. Today, your system and design needs require high reliability, faster speeds, and world-class quality. From prototype to production, Powell has the solutions.



NEW! IBBC-TP for TPPL

The 2019 update to ISO 11783 defines and describes the network's 250 kbit/s, non-shielded, twisted pair-cable with physical layer. The new architecture is named twisted pair physical layer (TPPL). TPPL achieves a 250 kbit/s, un-shielded, twisted pair cable network layer which is fully backward compatible to twisted quad based machines and devices.

NEW PRODUCTS



PAPIL4C-R / PAPIL4C-P Power Connectors

The PAPIL series is a part of our exclusive Agricultural Solutions line. The PAPIL series is developed for ISO 11783-2 applications where the power needs to be split way from the CAN lines. Therefore it is developed to the same specifications as all ISOBUS connectors in the Powell Agricultural Solutions portfolio. It comes in a 4 pole version with 2 x AWG 12 and 2 x AWG 8.



PAS HSI Gb Ethernet Switch

The PAS88160007 offers 7 Ports of sealed single pair ethernet connectors with IEEE802.3bp Type A (15 M) & Type B (40 M) supported. Active link and passive link partners can be connected over 1 Gb/s network backbone. Perfect to connect smart cameras and displays over long lengths with additional controllers involved. TC9 Class 2 Shielded interfaces with IP67 and IP69 sealing performance.



Mechanical Features

- Compact design allows for ease of mounting in tight spaces
- Rear-mating IBRC connector allows for plug & play installation
- Retains functionality after many breakaways
- Corrosion resistant
- Latching handle allows for easy mating and release of connector
- Environmental protection of IP69 when mated, IP67 unmated

Electrical Features

- Little electrical de-rating and fretting after many breakaway cycles
- Rear-mating IBRC allows for easy power disconnect and safe replacement
- Replaceable PCB

Commercial Features

- Cost effective premium solution for ISO 11783-2 applications
- Readily available; can provide program supply worldwide

Specifications

Enclosure	Over molded polypropylene
Handle	Die cast aluminum
Connectors	Implement Side: 1x 9-pin Tractor Side: 2x 4-pin
Latch / Release	Spring loaded, holds securely onto locking tower
Connector Lid	Spring loaded to remain closed when mating connector is not in use; Automatically closes upon connector breakaway

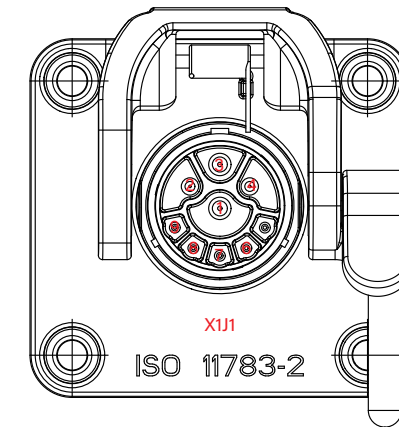
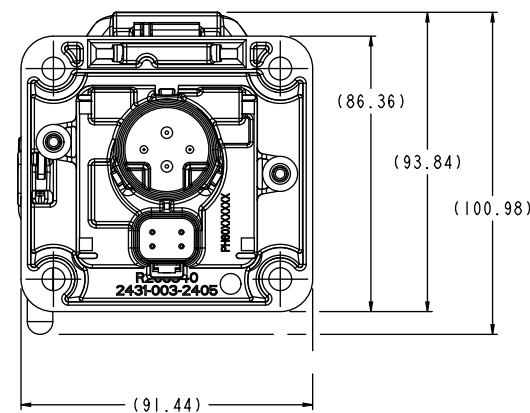
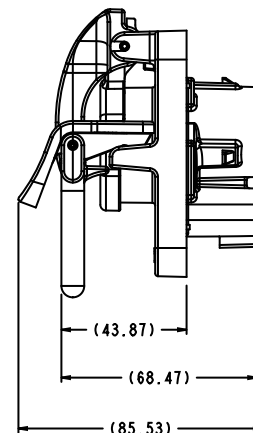
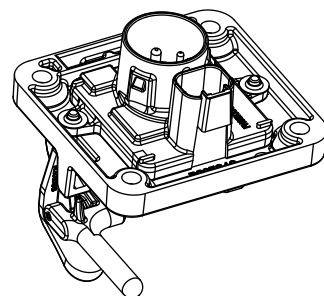
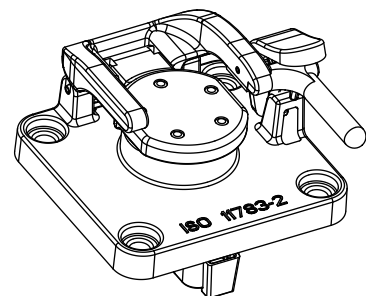
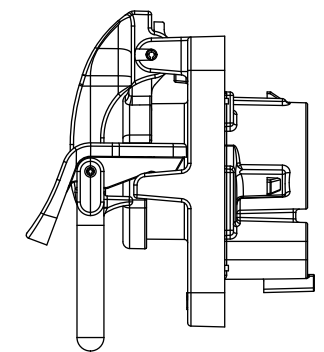
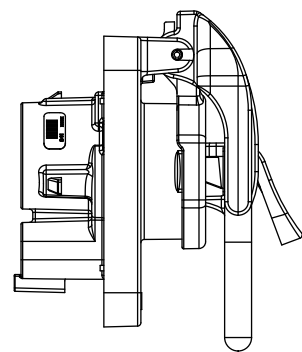
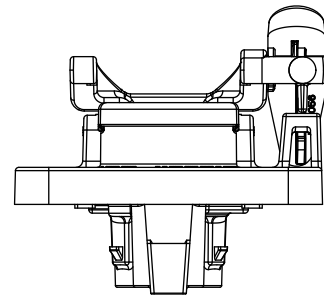
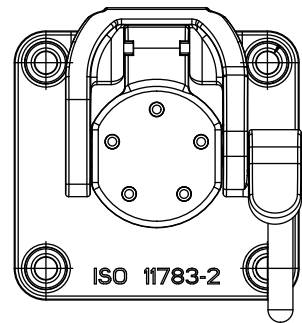

Implement Side Connection for IBIC™

Mating Connector IBIC™ (X1J1) for Implement Side Connections

- 1 Pass through ground
- 2 Electronic control unit (ECU) ground
- 3 Pass through power
- 4 ECU power (6-16 Vdc)
- 5 Return power to integrated relay
- 6 TBC power (6-26 Vdc)
- 7 TBC return
- 8 CAN high (2500, 75 ± 5 Ω termination resistance)
- 9 CAN low (2500, 75 ± 5 Ω termination resistance)

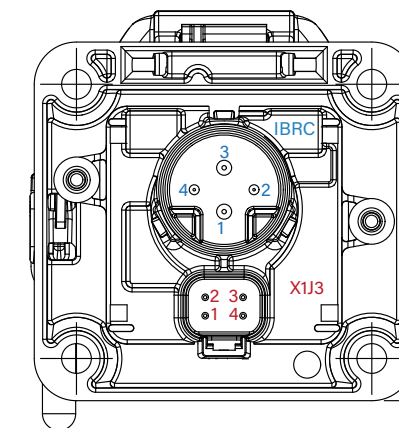

Tractor Side Connection for IBRC Connector and X1J3

Connector IBRC for Tractor Side Connections

- 1 Pass through ground
- 2 Electronic control unit (ECU) ground
- 3 Pass through power
- 4 ECU power (6-16 Vdc)

Connector X1J3 for Tractor Side Connections

- 1 TBC power (6-16 Vdc)
- 2 CAN high (2500, 75 ± 5 Ω termination resistance)
- 3 TBC return
- 4 CAN low (2500, 75 ± 5 Ω termination resistance)



Features

- Uses ECU power and FETs to dynamically connect/disconnect a 120 ohm resistor based on whether the implement harness is connected or not
- Creates a 250kbit/s network using unshielded twisted pair cable and is fully backwards compatible
- Terminates on tractor ECU for cost savings
- IBBC-TP design will not have a gold finish on the connector pins which saves cost without compromising signal integrity
- Gray over molding differentiates IBBC-TP from current 4-wire primary (black) and secondary (white) offerings
- No mechanical changes in form/fit

Specifications

Enclosure	Over molded polypropylene
Handle	Die cast aluminum
Connectors	Implement Side: 1x 9-pin Tractor Side: 2x 4-pin
Latch / Release	Spring loaded, holds securely onto locking tower
Connector Lid	Spring loaded to remain closed when mating connector is not in use; Automatically closes upon connector breakaway

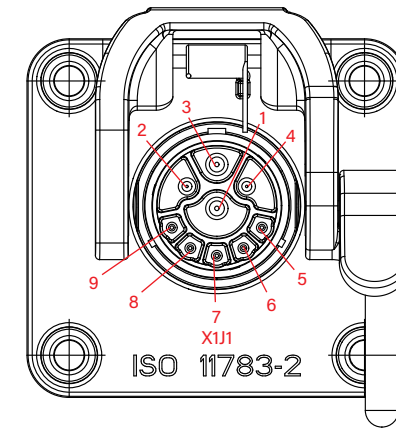
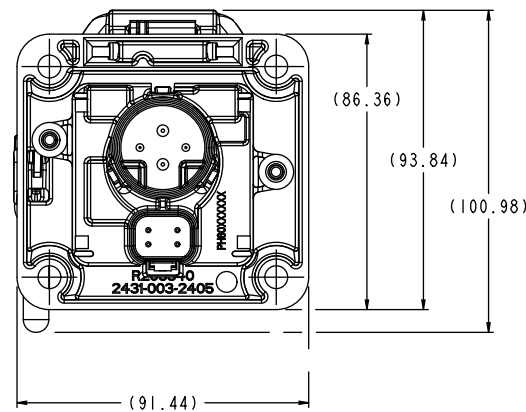
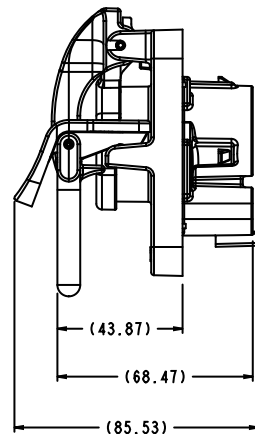
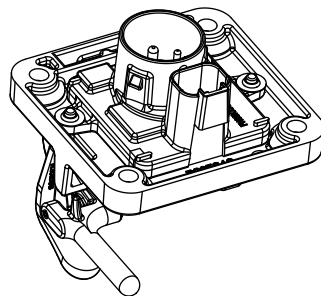
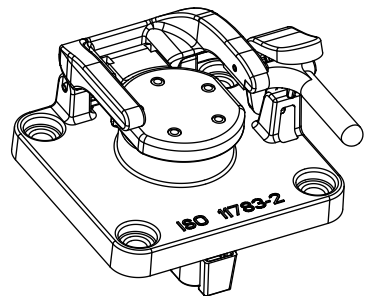
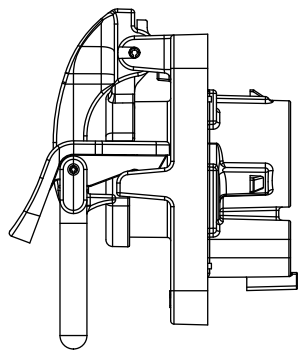
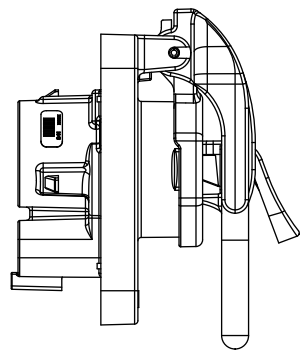
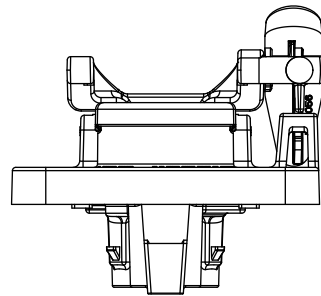
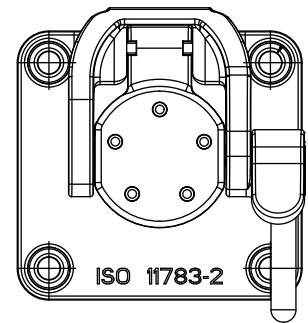

Implement Side Connection for IBIC™

Mating Connector IBIC™ (X1J1) for Implement Side Connections

- 1 Pass through ground
- 2 Electronic control unit (ECU) ground
- 3 Pass through power
- 4 ECU power (6-16 Vdc)
- 5 Return power to integrated relay
- 6 TBC power (6-26 Vdc)
- 7 TBC return
- 8 CAN high (2500, 75 ± 5 Ω termination resistance)
- 9 CAN low (2500, 75 ± 5 Ω termination resistance)

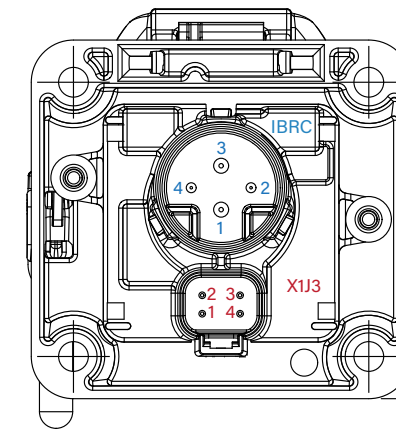

Tractor Side Connection for IBRC Connector and X1J3

Connector IBRC for Tractor Side Connections

- 1 Pass through ground
- 2 Electronic control unit (ECU) ground
- 3 Pass through power
- 4 ECU power (6-16 Vdc)

Connector X1J3 for Tractor Side Connections

- 1 TBC power (6-16 Vdc)
- 2 CAN high (2500, 75 ± 5 Ω termination resistance)
- 3 TBC return
- 4 CAN low (2500, 75 ± 5 Ω termination resistance)



Features

- Rapid population and simple assembly
- Ergonomic design, no sharp edges
- No special tooling required for assembly
- Strong, impact resistant construction
- Easily field-serviceable

Specifications	
Operating Temp	-30°C to +85°C
Storage Temp	Room Temperature
Weight	~100 grams excluding contacts
Cable OD	2x #8 AWG 2x #12 AWG 4x #16 AWG – 1x bridged
Maximum Power Capacity	2x 60 amp 2x 25 amp 4x 13 amp – 1x 13 amp bridged
Material	High-grade, non-corrosive plastic
Environmental Protection	IP67 mated and unmated

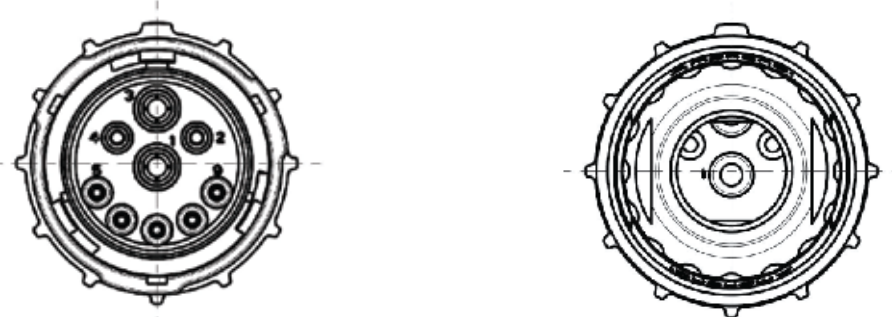
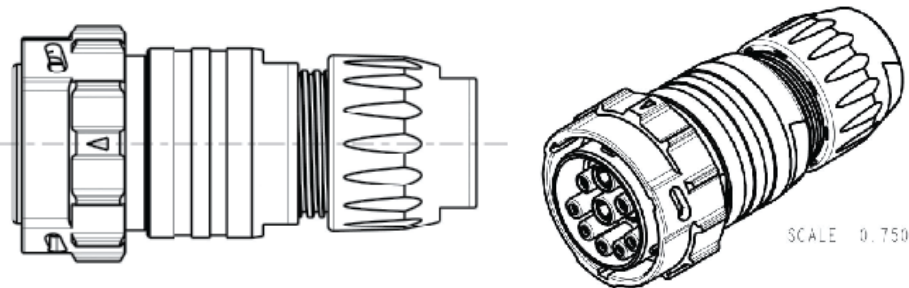
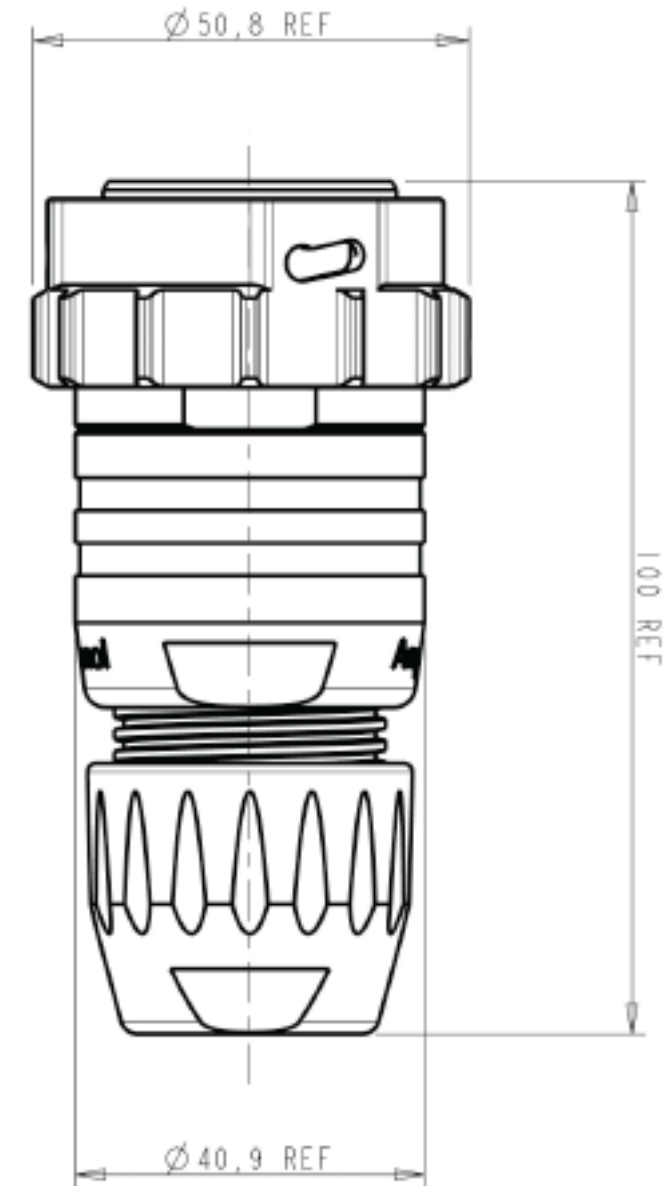



Waterproof Cap

Made from the same durable polymers as the IBIC™, the Waterproof Cap can be applied by direct connection to the IBIC™ with a strong lanyard or in a panel bracket.



Grommet Seals

Protects the IBIC™ wire and cable with flexible grommet seals. These seals are designed to handle UL Spec Wires (orange) or SAE Spec Wires (blue).

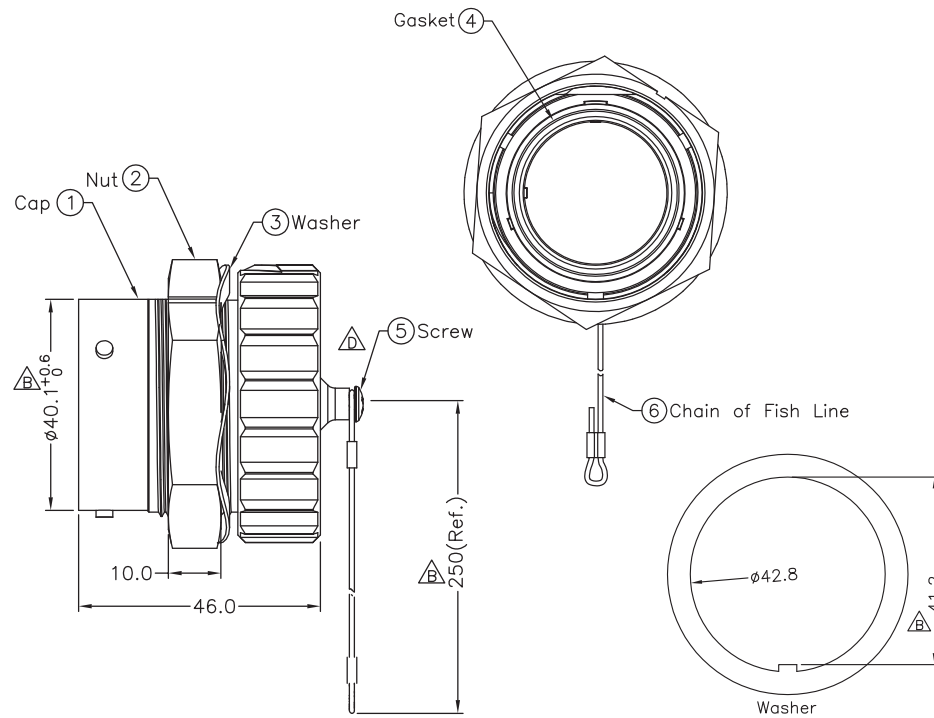
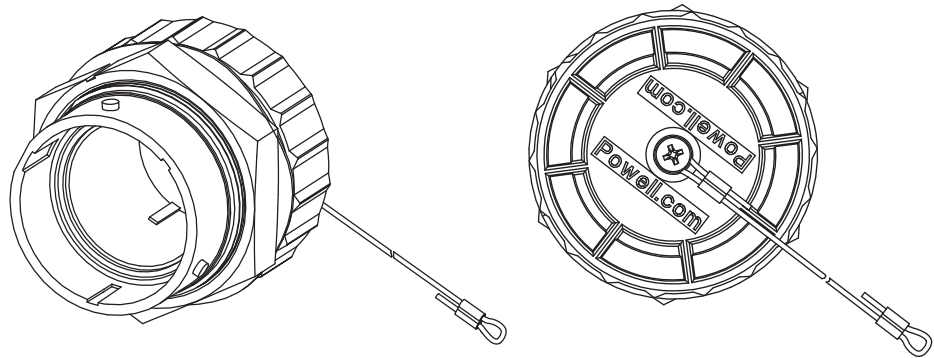

UL Spec Wires (Orange Wire Seal)			
Cavity Number	Conductor Diameter	Minimal Insulator Outer Diameter	Maximal Insulator Outer Diameter
1	#8	4.83 (0.190)	6.10 (0.240)
2	#12	3.40 (0.134)	4.23 (0.170)
3	#8	4.83 (0.190)	6.10 (0.240)
4	#12	3.40 (0.134)	4.23 (0.170)
5	#16	Need a terminal and sealing plug only	
6	#16	2.54 (0.100)	3.40 (0.134)
7	#16	2.54 (0.100)	3.40 (0.134)
8	#16	2.54 (0.100)	3.40 (0.134)
9	#16	2.54 (0.100)	3.40 (0.134)
Jacket Outer Diameter		14.0 (0.551)	18.0 (0.708)

SAE Spec Wires (Blue Wire Seal)			
Cavity Number	Conductor Diameter	Minimal Insulator Outer Diameter	Maximal Insulator Outer Diameter
1	#8	3.43 (0.135)	5.59 (0.220)
2	#12	2.46 (0.097)	4.01 (0.158)
3	#8	3.43 (0.135)	5.59 (0.220)
4	#12	2.46 (0.097)	4.01 (0.158)
5	#16	Need a terminal and sealing plug only	
6	#16	1.20 (0.047)	2.41 (0.095)
7	#16	1.20 (0.047)	2.41 (0.095)
8	#16	1.20 (0.047)	2.41 (0.095)
9	#16	1.20 (0.047)	2.41 (0.095)
Jacket Outer Diameter		14.0 (0.551)	18.0 (0.708)



Convolute Adapter

This adapter is extremely easy to mount and offers an IP 67 water resistance like the complete connector does. It's available in size 17 and 22, and offers UV and weathering resistance..



IBIC-R

IBIC-R

The IBIC-R is a standard receptacle with a hex nut to be mounted in a box or on a bracket on the tractor. This modular design enables it to be the most cost effective ISOBUS connector on the market

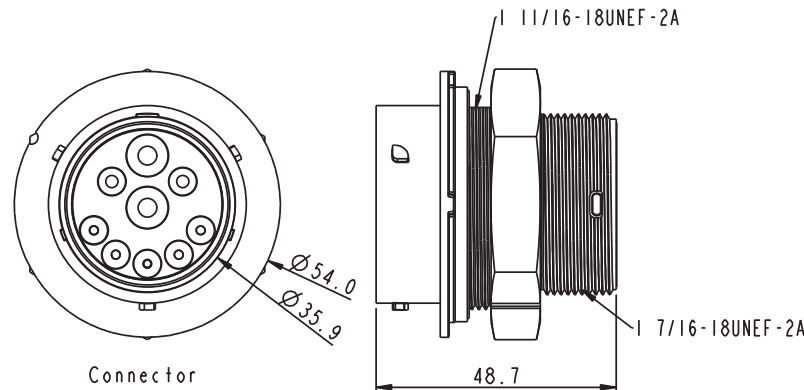

IBIC-RBS

IBIC-RBS

The IBIC-RBS is the same housing with a backshell and cable clamp to adopt a jacket cable used in all ISO 11783 applications throughout the world. It is meant to be mounted on a bracket and can be used to create an extension cable in ISOBUS applications or to equip TPPL architecture machinery.

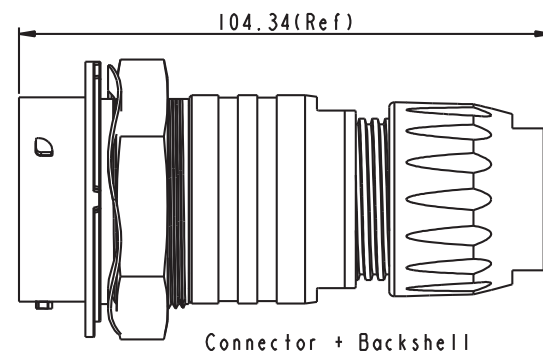

IBIC-RBSL

IBIC-RBSL

The IBIC-RBSL includes an IP69K lid to protect the interface when the implement is not connected. This can be used in all above applications and is constructed with the same high quality as all Powell Ag products.

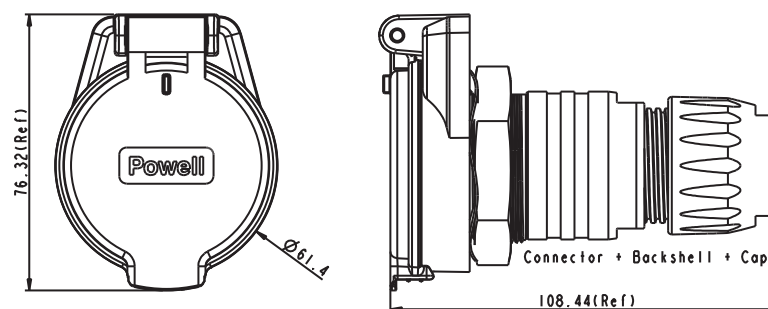

Specifications

Overall Dimensions	IBIC-R IBIC-RBS IBIC-RBSL	49 by ø 54 mm 105 by ø 54 mm 110 by ø 76 mm
Operational Temperature	-30° C to +85° C	
Storage Temperature	Room Temperature	
Populating Time	< 3 minutes	
Weight (excluding contacts)	IBIC-R IBIC-RBS IBIC-RBSL	71 grams 110 grams 140 grams
Cable Outer Diameter	< 18 mm / > 14 mm	
Contacts	2x #8 contacts 2x #12 contacts 4x #16 contacts 1x filler plug	
Max Power	2x 60 amp 2x 25 amp 4x 13 amp 1x plugged	
Material	High grade non-corrosive plastic	
Environmental Protection	IP69K mated or unmated with cap	

IBRC-3L

Three Latch Rear Connector



Features

- Three latch design provides increased mating stability and stress-free contact alignment
- Bright colored interfacial seal provides easy visual inspection for mating
- Environmentally protected to IP69K
- Allows for optional backshell or cable router
- Easy contact population

Grommet Seals

- Protect the IBRC™ wire and cable with flexible grommet seals.
- Designed to handle UL Spec Wires (orange) or SAE Spec Wires (blue) while sealing to IP69K.

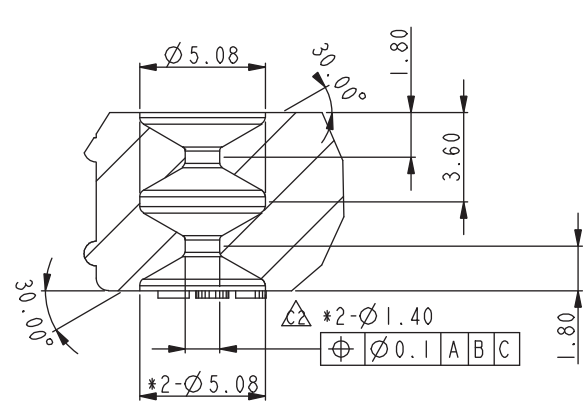
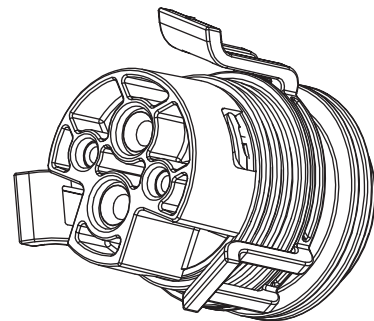
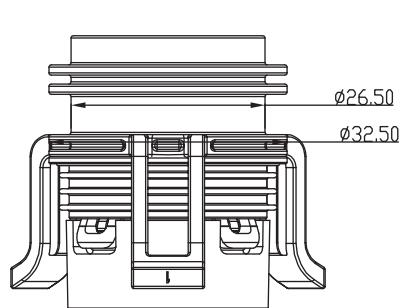
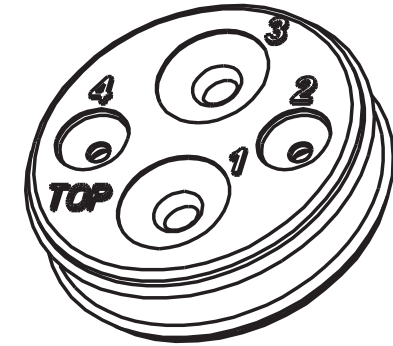

IBRC Grommet Seal for SAE spec wires

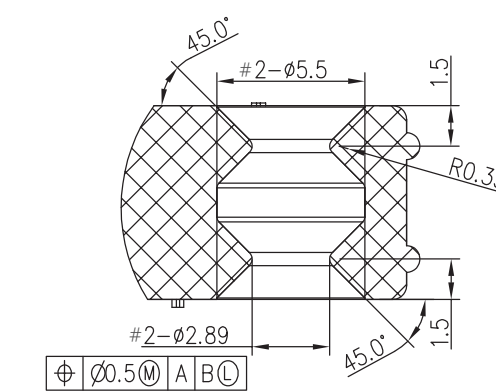
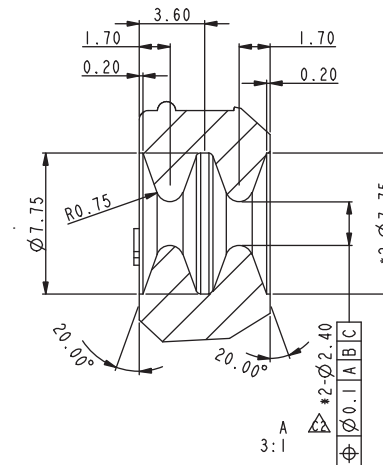

IBRC Grommet Seal for UL spec wires

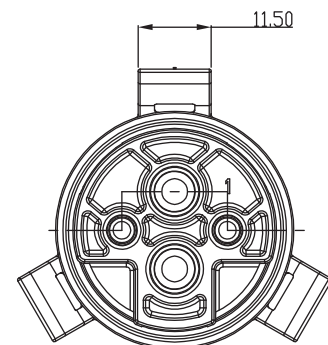
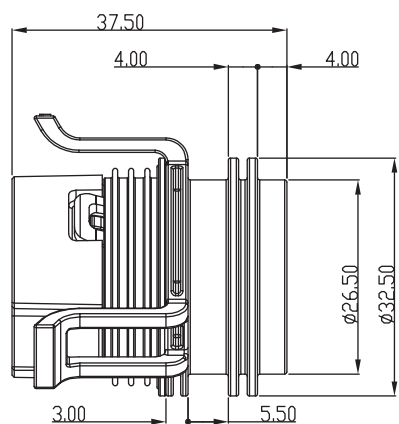
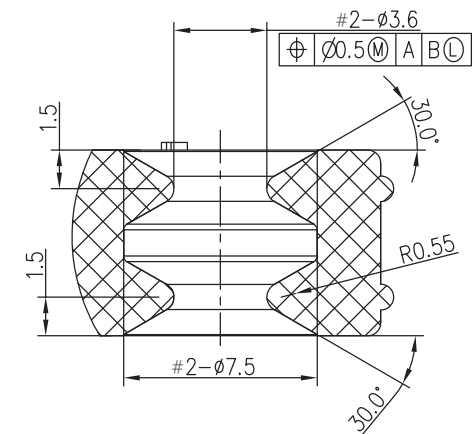

SAE Spec Wires (Blue Wire Seal)

Cavity Number	Conductor Diameter	Minimal Insulator Outer Diameter	Maximal Insulator Outer Diameter
1	#8	3.43 (0.135)	5.59 (0.220)
2	#12	2.46 (0.097)	4.01 (0.158)
3	#8	3.43 (0.135)	5.59 (0.220)
4	#12	2.46 (0.097)	4.01 (0.158)

UL Spec Wires (Orange Wire Seal)

Cavity Number	Conductor Diameter	Minimal Insulator Outer Diameter	Maximal Insulator Outer Diameter
1	#8	4.83 (0.190)	6.10 (0.240)
2	#12	3.40 (0.134)	4.23 (0.170)
3	#8	4.83 (0.190)	6.10 (0.240)
4	#12	3.40 (0.134)	4.23 (0.170)

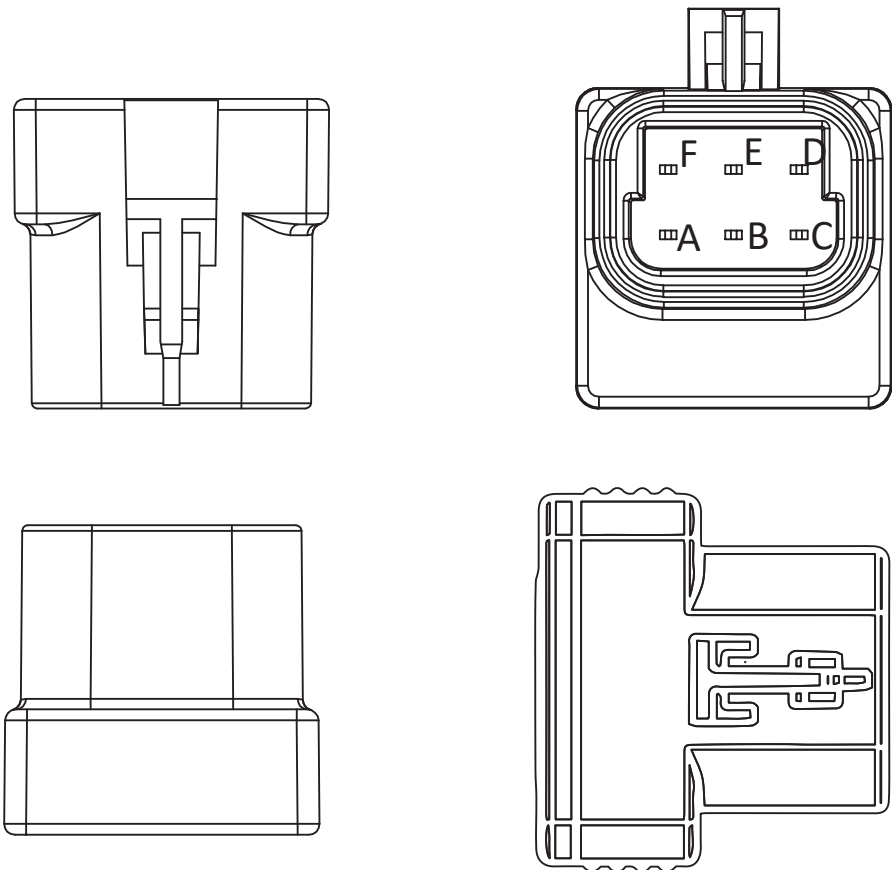

Features

- Cost-effective solution for providing active termination for CAN Bus vehicle networks
- Maintains full compatibility with ISO 11783-2 and SAE J1939 specs
- Plugs directly into vehicle harness without additional mounting hardware.

Specifications

Enclosure	Over molded polypropylene
Rated Voltage	13.5 Vdc
Operating Voltage Range	6 to 16 Vdc
Max Current	0.1 amp
Operating Temperature	-40°C to +75°C
Storage Temperature	-55°C to +105°C

Mating Connector - Delphi Part Numbers

Connector Shell	12052848-B
Terminal	12048074
Wire Seal	12048086
Cavity Plug	12059168

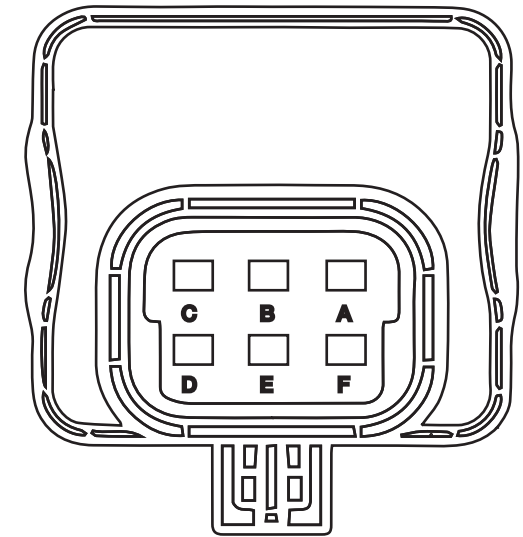

Pin Connections

A	Electronic Control Unit (ECU) Power
B	Terminator Power Line (6 to 16 Vdc)
C	Electronic Control Unit Ground
D	Terminator Return Line
E	CAN High (2500 V, 75 ± 5 Ω termination resistance)
F	CAN Low (2500 V, 75 ± 5 Ω termination resistance)

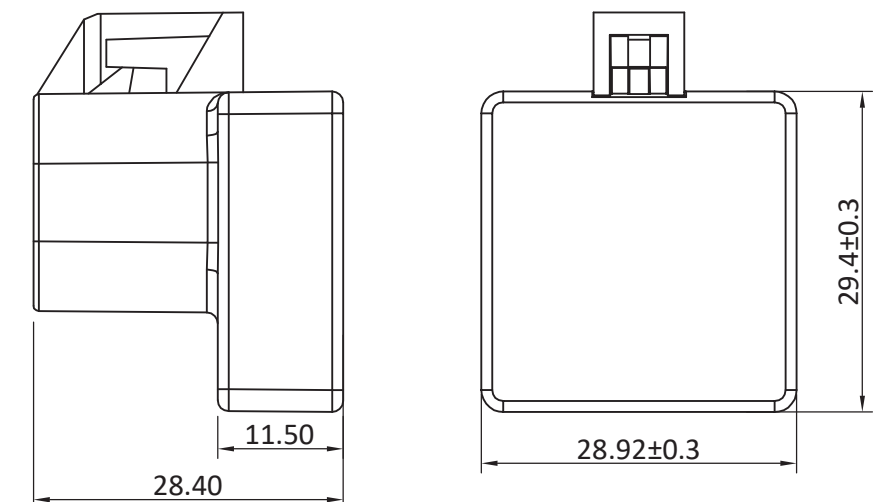



The PAPIL series is a part of our exclusive Agricultural Solutions line. The PAPIL series is developed for ISO 11783-2 applications where the power needs to be split way from the CAN lines. Therefore it is developed to the same specifications as all ISOBUS connectors in the Powell Agricultural Solutions portfolio. It comes in a 4 pole version with 2 x AWG 12 and 2 x AWG 8.

Features

- High-grade non-corrosive construction
- Easy to operate
- Fast and simple population process
- No special tooling required
- Will not damage when dropped
- Ease of mating due to clip marker

Specifications

Number of Cavities	4
Size of Cavities	2x #12 2x #8
PN Plug Housing	PAPIL4C-P
PN Receptacle Housing	PAPIL4C-R
Environmental Protection	IP67 (mated)

PAPIL4C-P

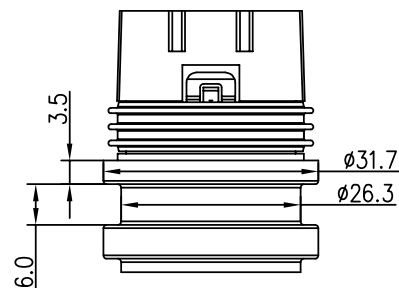
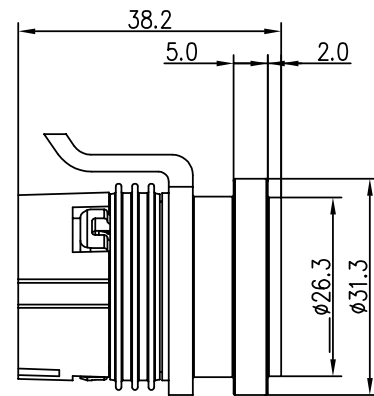
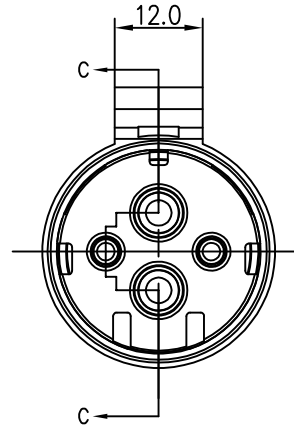

PAPIL4C-R

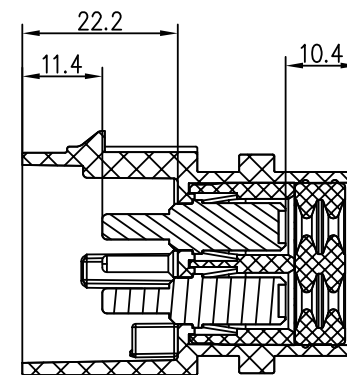
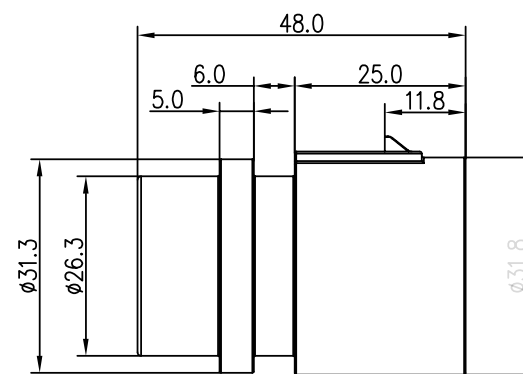
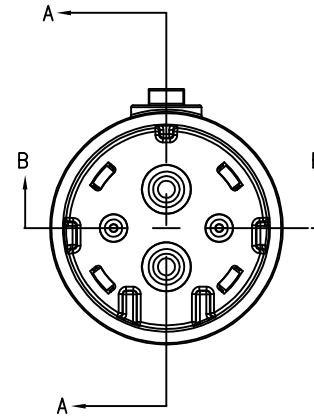

Grommet Seals

- Protect the IBRC™ wire and cable with flexible grommet seals.
- Designed to handle UL Spec Wires (orange) or SAE Spec Wires (blue) while sealing to IP69K.

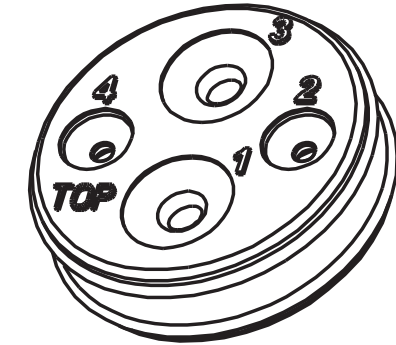

SAE Spec Wires (Blue Wire Seal)

Cavity Number	Conductor Diameter	Minimal Insulator Outer Diameter	Maximal Insulator Outer Diameter
1	#8	3.43 (0.135)	5.59 (0.220)
2	#12	2.46 (0.097)	4.01 (0.158)
3	#8	3.43 (0.135)	5.59 (0.220)
4	#12	2.46 (0.097)	4.01 (0.158)

UL Spec Wires (Orange Wire Seal)

Cavity Number	Conductor Diameter	Minimal Insulator Outer Diameter	Maximal Insulator Outer Diameter
1	#8	4.83 (0.190)	6.10 (0.240)
2	#12	3.40 (0.134)	4.23 (0.170)
3	#8	4.83 (0.190)	6.10 (0.240)
4	#12	3.40 (0.134)	4.23 (0.170)

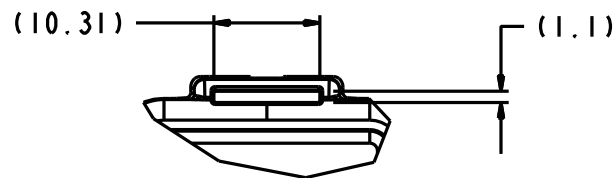
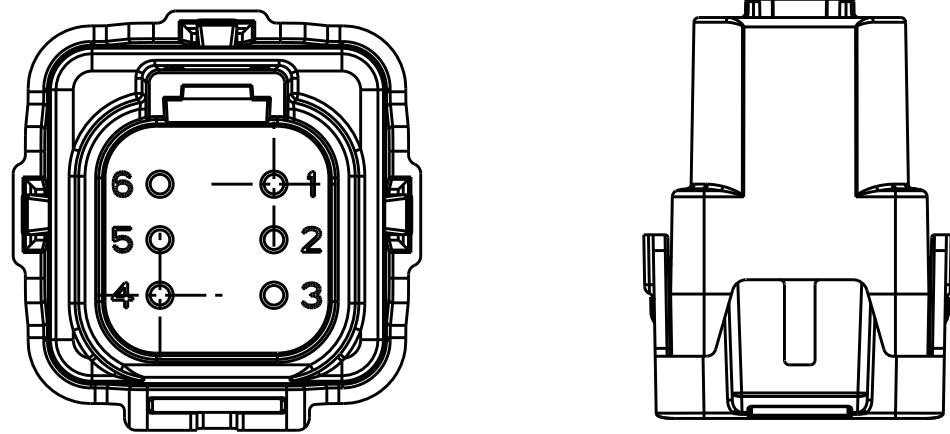

DETAIL A
SCALE 2:1

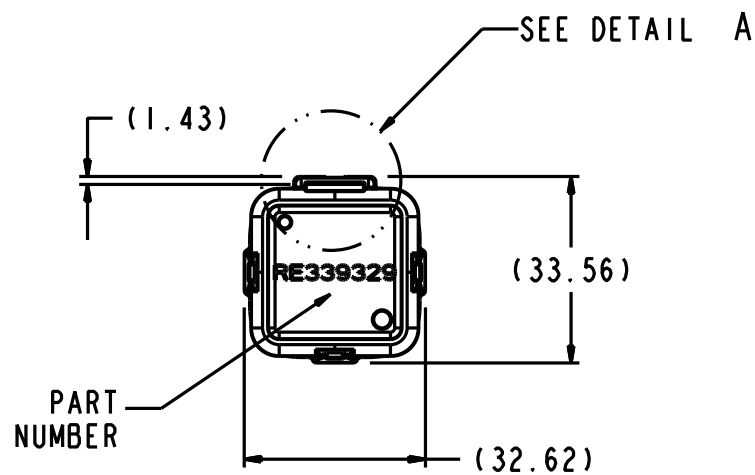

Features

- Meets requirements of the OICC as specified in ISO 11783-2
- Used to connect and disconnect CAN lines as part of the function of the system
- Allows optional CAN devices to be connected on the Implement CAN bus while maintaining topology requirements
- Compatible with any ISO 11783-2 device for in-cab use (e.g. display, rate controller, keypad, etc.)

ISOBUS Relay

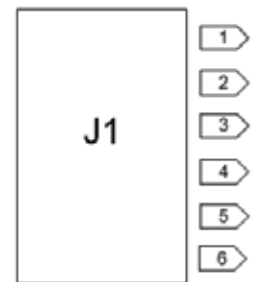

Mating Harness

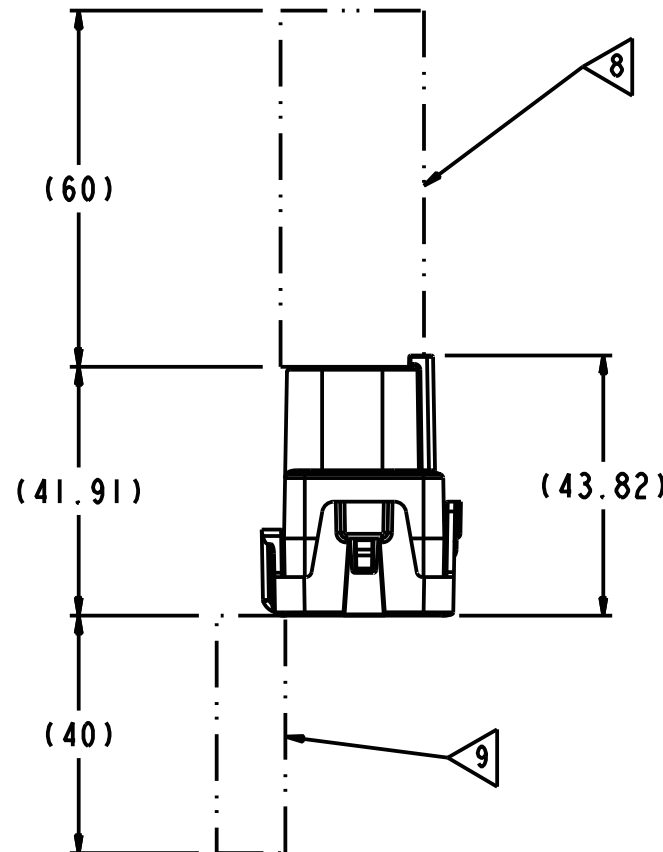
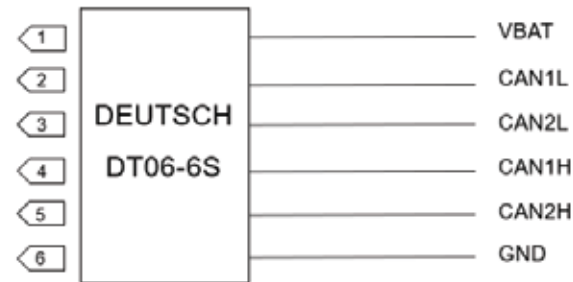

Wiring Guide

To wire this up with the in-cab connector, please follow ISO 11783-2 Physical layer standard (reference ISO 11783 console connector, pinout described in ISO 11783-2, section 7.6.4). This way will keep the main Bus passing through the OICC Relay.

When in need for additional components (ECUs, auxiliary inputs), those can be plugged into the ISO 11783 console connector and provide power to the relay to open it. This will break the main bus to extend it to the new devices and effectively extending the bus.

For the connectors, please use AT06-6S or DT06-6S variants. There are many variations available that depend on the type of wire, seal, covers, colors, etc.

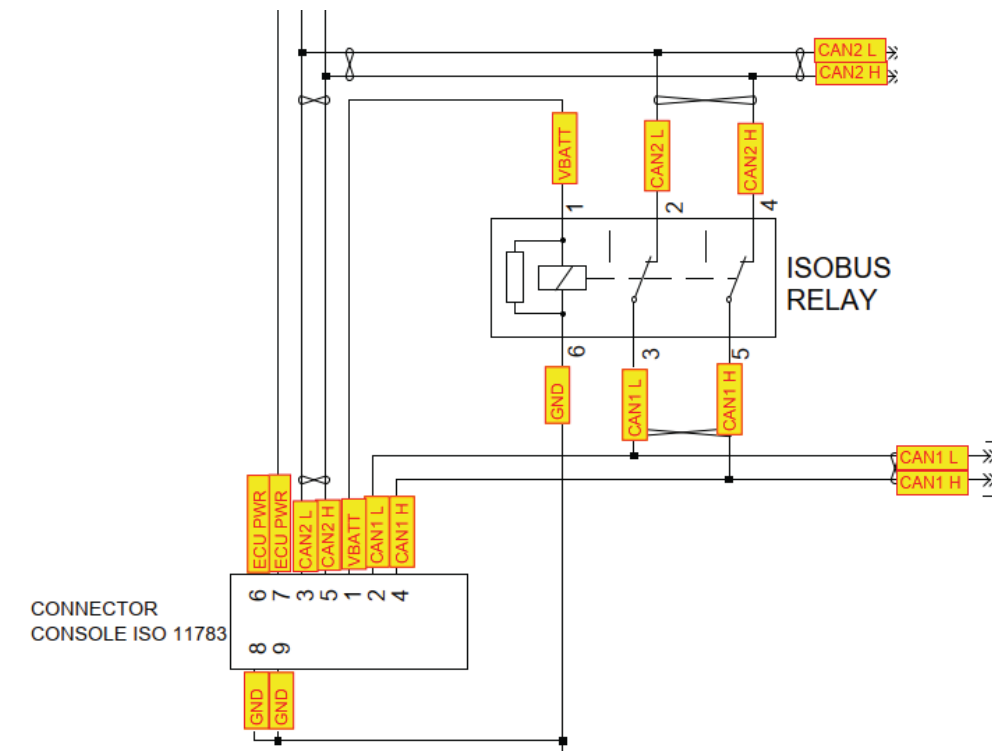

ISOBUS Jacketed Cable

Jacketed Cable PUR 6mm and PVC 10mm



PUR 6mm Jacketed Cable



PVC 10mm Jacketed Cable

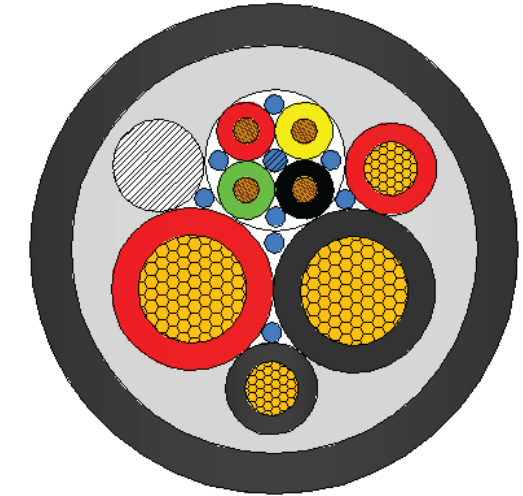

Features

Our ISOBUS Jacketed Cable is the heavy-duty cable design for connecting all of our Powell Ag components and more. The layered cable elements consist of stranded plain copper wires; a TPR and PVC insulation and a black PUR or PVC sheath. This allows for accelerated, reliable communication and sustained connection even in harsh temperatures. The four CAN wires are twisted 50 til 52 mm/turn – an important feature for reducing electromagnetic interference.

PAS Cables

We designed these heavy-duty vehicle cables with the latest in ISOBUS Connectors. Ordered to a custom length we provide ISO 11783 (9 pin) plugs and receptacles that can be used as extensions and adapters for the precision Ag machinery ISOBUS systems.

Both the plugs and receptacle have lids and are sealed from all types of moisture and sediment ingress to IP68. Made in the USA, these are the longest lasting and most cost-effective solutions for ISOBUS extensions and adapters..

Specifications	
Conductor	Stranded plain copper wire, IEC 60228 Class 5
Insulation	0.5 mm ² PVC
	2.5 mm ² TPR
	6.0 mm ² TPR
Colors of Insulation	0.5 mm ² red, yellow, black, green
	2.5 mm ² red, black
	6.0 mm ² red, black
Stranding	Cable elements are stranded together in layers
Filler	Halogen-free filling compound
Outer Sheath	PUR
Color of Sheath	Black

Specifications	
Conductor	Stranded plain copper wire, IEC 60228 Class 5
Insulation	0.5 mm ² PVC
	2.5 mm ² TPR
	10.0 mm ² TPR
Colors of Insulation	0.5 mm ² red, yellow, black, green
	2.5 mm ² red, black
	10.0 mm ² red, black
Stranding	Cable elements are stranded together in layers
Filler	Halogen-free filling compound
Outer Sheath	PVC
Color of Sheath	Black

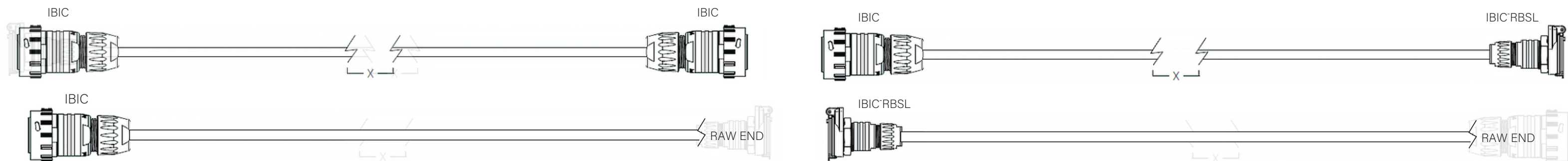

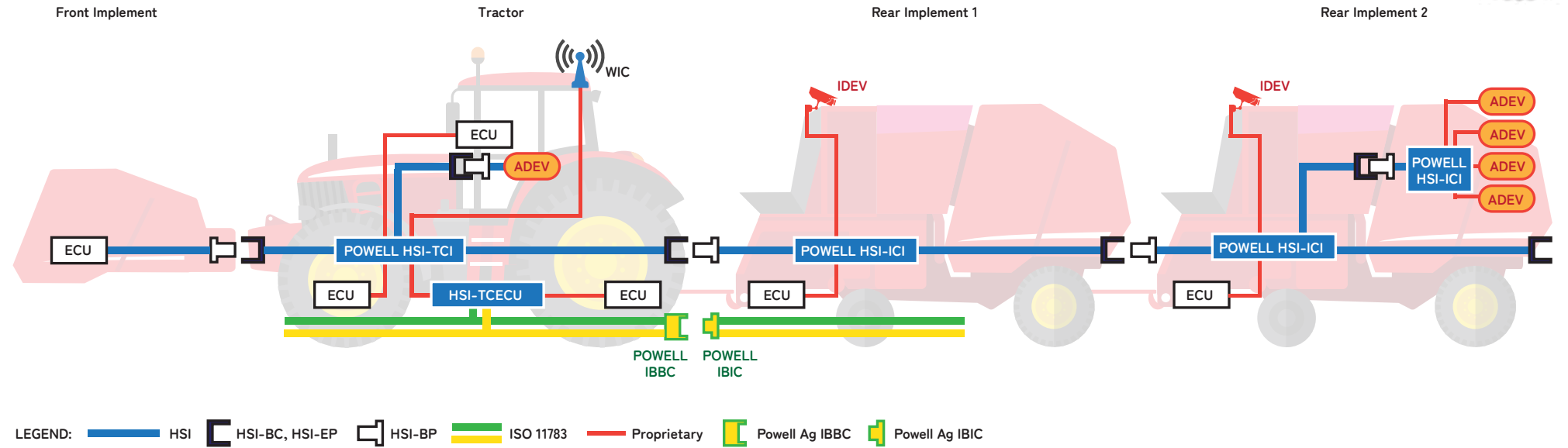
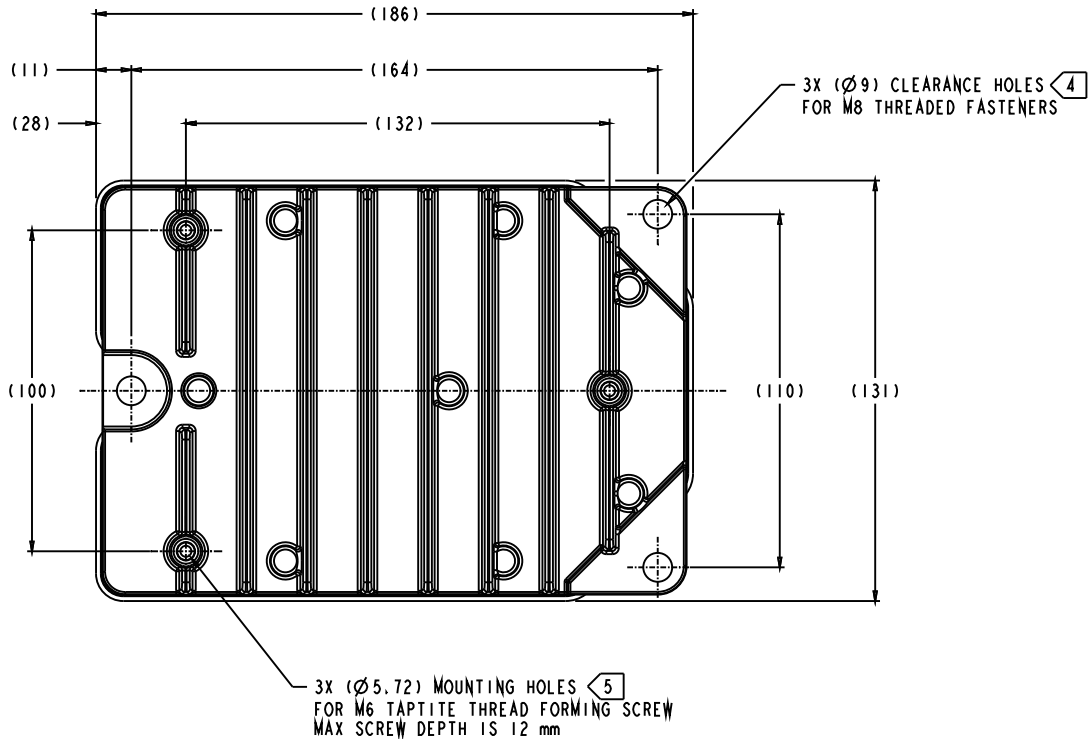
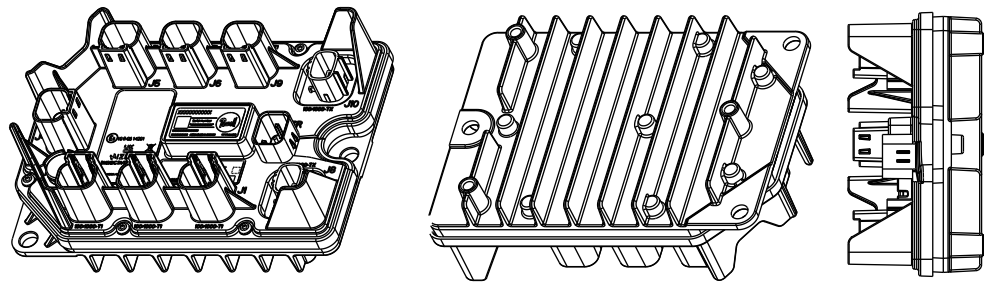

KEY:

- Powell HSI-TCI** (Tractor Control Interface, Network Switch)
- Powell HSI-ICI** (Implement Control Interface, Network Switch)
- ECU** (Electronic Control Unit)
- HSI-TECU** (Gateway between tractor private network(s) and HSI)
- IDEV** (Integrated Device)
- ADEV** (Aftermarket Device)
- WIC** (Wireless Infield Communication Device)

Features

- Supports 12/24 V
- IEEE802.3bp Type A (15 M) & Type B (40 M) supported
- Auto-negotiation for Ethernet at 100 Mbps or 1 Gbps
 - Auto-negotiation is still being defined
- Diagnostics – requirements are still being defined
- Meets AEF HS-ISOBUS requirements
- IP67 Enclosure with connectors mated
- Operating temperature of -40°C to +85 °

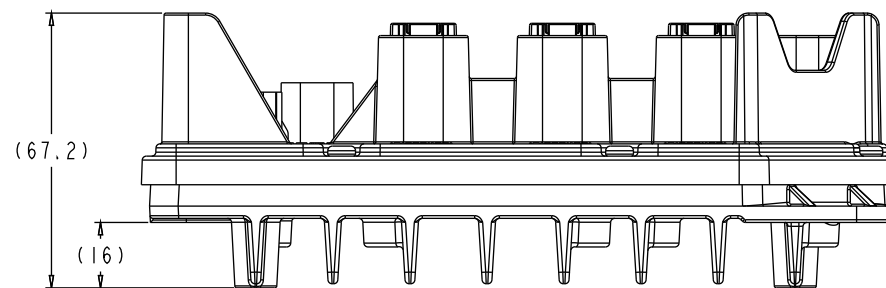

Machine Interfaces		PN
Primary Connector	TE-Ampseal-16, 4 POS	776487-1
(6) 100/1000BASE-T1 Ports with Link Partnership Negotiation	Header 2-Pin PCB Connector Mating Shell (Rev A Key)	9-2370706-1 9-2367337-1
(1) 1000BASE-T1 Port with Active Link Partnership	Header 2-Pin PCB Connector Mating Shell (Rev C Key)	9-2370706-1 9-2367337-3
(2) 10/100BASE-Tx Ports	Molex-HS AutolinkII	34858-0106

Programming and Application Development	
Boot Loader	Reprogrammable using UDS protocol Basic 100/1000 switch behavior Initializes all Ethernet ports
Programming Tool	vFlash
Application Options	Diagnostics via UDS protocol Configurable via UDS protocol MACsec Authenticator role settings available IEEE 802.1 settings available SOME/IP, ISN
Supported Transfer Protocols	RTSP/TCP IP/UDP

PAS Dual Beam Radar

Dual Beam Radar



Features

Two independent radar beams, 90 degrees offset from each other, are emitted from an antenna in each horn making the radar highly accurate. Having two sources of speed measurement reduces dropouts.

While this signal is useful for the information displays, it also enables closed-loop control systems, such as variable rate application techniques, and intelligent vehicle driveline management. A reliable true ground speed signal will also support emerging autonomous vehicle concepts.

The Dual Beam Radar has passed the full spectrum of tests specified in the ASAE EP-455 Standard for electronics on mobile equipment including temperature, vibration, moisture, dust, electrical, and electromagnetic compatibility (EMC) tests. The unit also meets the requirements of the R&TTE directive and is CE compliant.

Part Numbers

- PAS90212659 (+12V, 1.2W) – N. America
- PAS90212662 (+12V, 0.1W) – Europe
- PAS90212666 (+24V, 1.2W) – N. America
- RE324688C – Mounting Kit

Operational Control

- Speed output on the radar has been designed to interface with multiple user devices

Radar Enclosure

- Completely sealed unit can be submerged underwater
- Metal housing enhances the ESD performance, and acts as a heat sink for the transceivers

CAN Capabilities

- The Dual Beam Radar's design is CAN (Controller Area Network) based. CAN allows data to be transmitted to all controllers simultaneously. Vehicle direction is also determined and can be transmitted per ISO CAN standards.
- Transceivers and sensor can be disabled during operation
- Diagnostic capabilities

Specifications	
Velocity Range	0.5 to 62 mph (0.8 to 100 km/h)
Accuracy	≤±5% 0.5 to 1.3 mph (0.8 to 2.0 km/h)
	≤±2% 1.3 to 37.3 mph (2.0 to 60 km/h)
	≤±5% 37.3 to 62 mph (60 to 100 km/h)
Output Frequency	57.42 Hz/mph (35.6717 Hz/km/h)
Square Wave Output	VOH ≥ + V (battery)-1.5V @ IOH = 30 mA VOL ≤ 0.6 V @ IOL = 30 mA
Start/Stop Delay	≤ 250 milliseconds
	≤ 25 cm
Microwave Frequency	24.125 GHz (standard)
Mounting Angle	Horizontal ± 10°
Mounting Height	18 to 60 inches from target surface (457 to 1524 mm)
Mounting Fasteners	(4) 8 mm cap screws. Hand start screws (and nuts if used) prior to applying torque of 19-28 Nm each.
Overall Dimensions	6.2 x 6.3 x 6.0 in (158 x 161 x 153 mm)
Weight	4 lbs (1.8 kg)

Specifications	
Connector	Delphi Metri-Pack (10-pin) Mating Connector P/N: 12048226
	Pin A Reserved
	Pin B Reserved
	Pin C Speed Output
	Pin D CAN High
	Pin E Ground
	Pin F Supply Power
	Pin G CAN Low
	Pin H Reserved
	Pin J Reserved
Pin K Reserved	
Electrical Supply	+9 to +16 Vdc input voltage range ≤ 500 mA
	+9 to +32 Vdc input voltage range ≤ 500 mA (optional for some configurations)
Electrical Protection	Standard transient and steady state electrical protection (short circuit, reverse polarity, load dump, ESD, etc.) Product will survive submersion with mating harness connected
Output Power	1.8 W EIRP Standard
	100 mW EIRP EU Version
Regulatory Compliance	FCC IC CE
Storage Temperature	-104°F to +185°F (-40°C to +85°C)
Operating Temperature	-86°F to +185°F (-30°C to +85°C)

Appendix A

IBRC-3L Technical Drawing

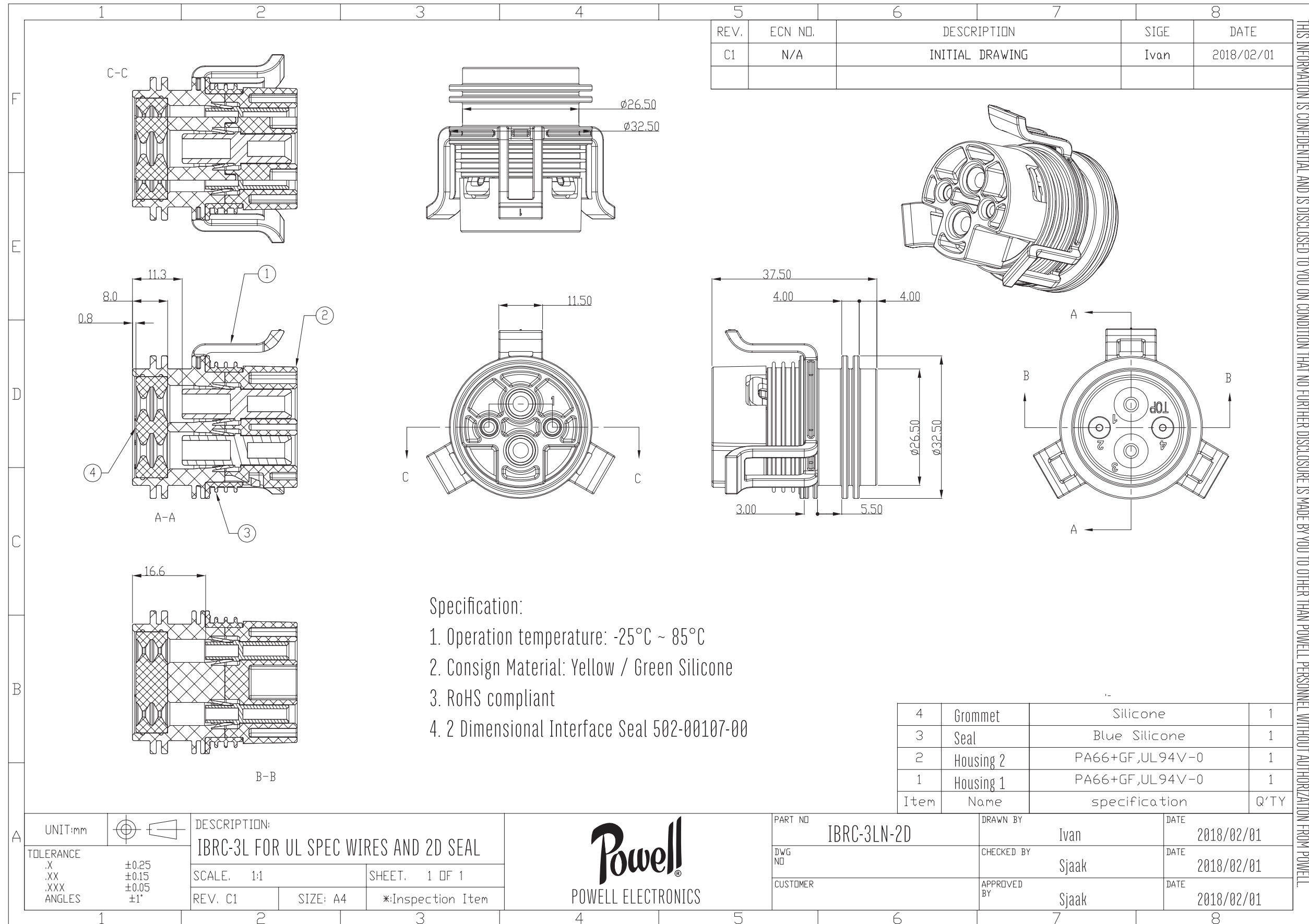

REV.	ECN NO.	DESCRIPTION	SIGE	DATE
C1	N/A	INITIAL DRAWING	Ivan	2018/02/01

THIS INFORMATION IS CONFIDENTIAL AND IS DISCLOSED TO YOU ON CONDITION THAT NO FURTHER DISCLOSURE IS MADE BY YOU TO OTHER THAN POWELL PERSONNEL WITHOUT AUTHORIZATION FROM POWELL.

- Specification:
1. Operation temperature: -25°C ~ 85°C
 2. Consign Material: Yellow / Green Silicone
 3. RoHS compliant
 4. 2 Dimensional Interface Seal 502-00107-00

Item	Name	specification	Q'TY
4	Grommet	Silicone	1
3	Seal	Blue Silicone	1
2	Housing 2	PA66+GF,UL94V-0	1
1	Housing 1	PA66+GF,UL94V-0	1

UNIT:mm		DESCRIPTION: IBRC-3L FOR UL SPEC WIRES AND 2D SEAL
TOLERANCE .X ±0.25 .XX ±0.15 .XXX ±0.05 ANGLES ±1°	SCALE: 1:1	SHEET. 1 OF 1
	REV. C1	SIZE: A4 *Inspection Item



PART NO IBRC-3LN-2D	DRAWN BY Ivan	DATE 2018/02/01
DWG NO	CHECKED BY Sjaak	DATE 2018/02/01
CUSTOMER	APPROVED BY Sjaak	DATE 2018/02/01

REV.	ECN NO.	DATE	SIGN	DESCRIPTION
01		2017/09/28	Neo	New

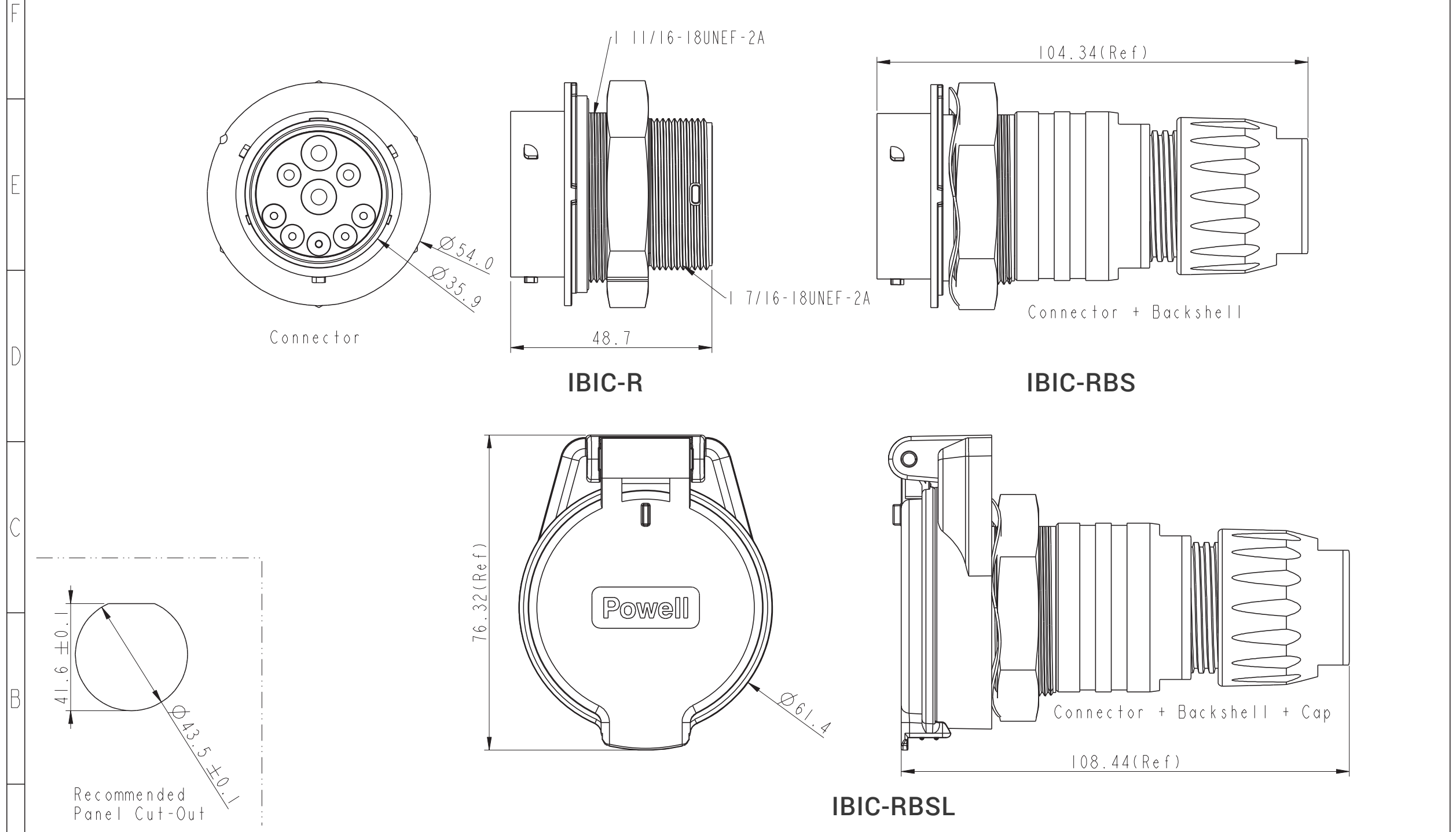

A	UNIT: mm	TITLE: IBIC Plane Connector			Powell Electronics Inc. IBIC-R IBIC-RBS IBIC-RBSL	ITEM NO: IBIC-RXXX	DRAWN BY: Neo	DATE: 2017/09/28
	TOLERANCE .X ±0.25 .XX ±0.1 .XXX ±0.05 ANGLES ±1°	SCALE: 4:5	SIZE: A4	SHEET: 1 OF 2		DWG NO: IBIC-RXXX	CHECKED BY: Sjaak	DATE: 2017/09/28
	REV: 01	WC-REV: A.6	QC: Inspection item			CAGE CODE: 20441	APPROVED BY: Max	DATE: 2017/09/28
						8 W10814-03-RW01A1		

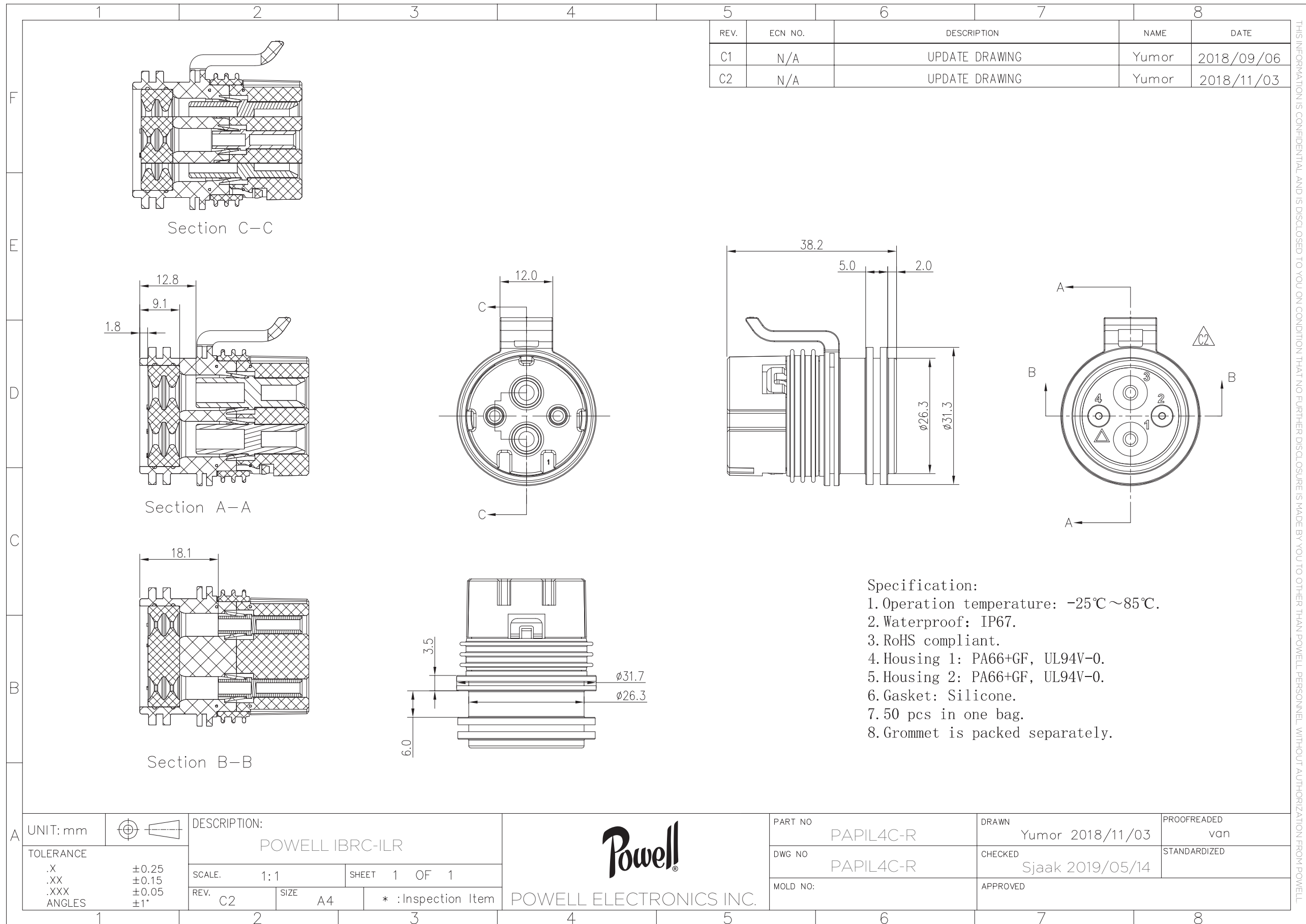

THIS INFORMATION IS CONFIDENTIAL AND IS DISCLOSED TO YOU ON CONDITION THAT NO FURTHER DISCLOSURE IS MADE BY YOU TO OTHER THAN POWELL PERSONNEL WITHOUT AUTHORIZATION FROM POWELL.

Appendix D

PAPIL4C-P Technical Drawing

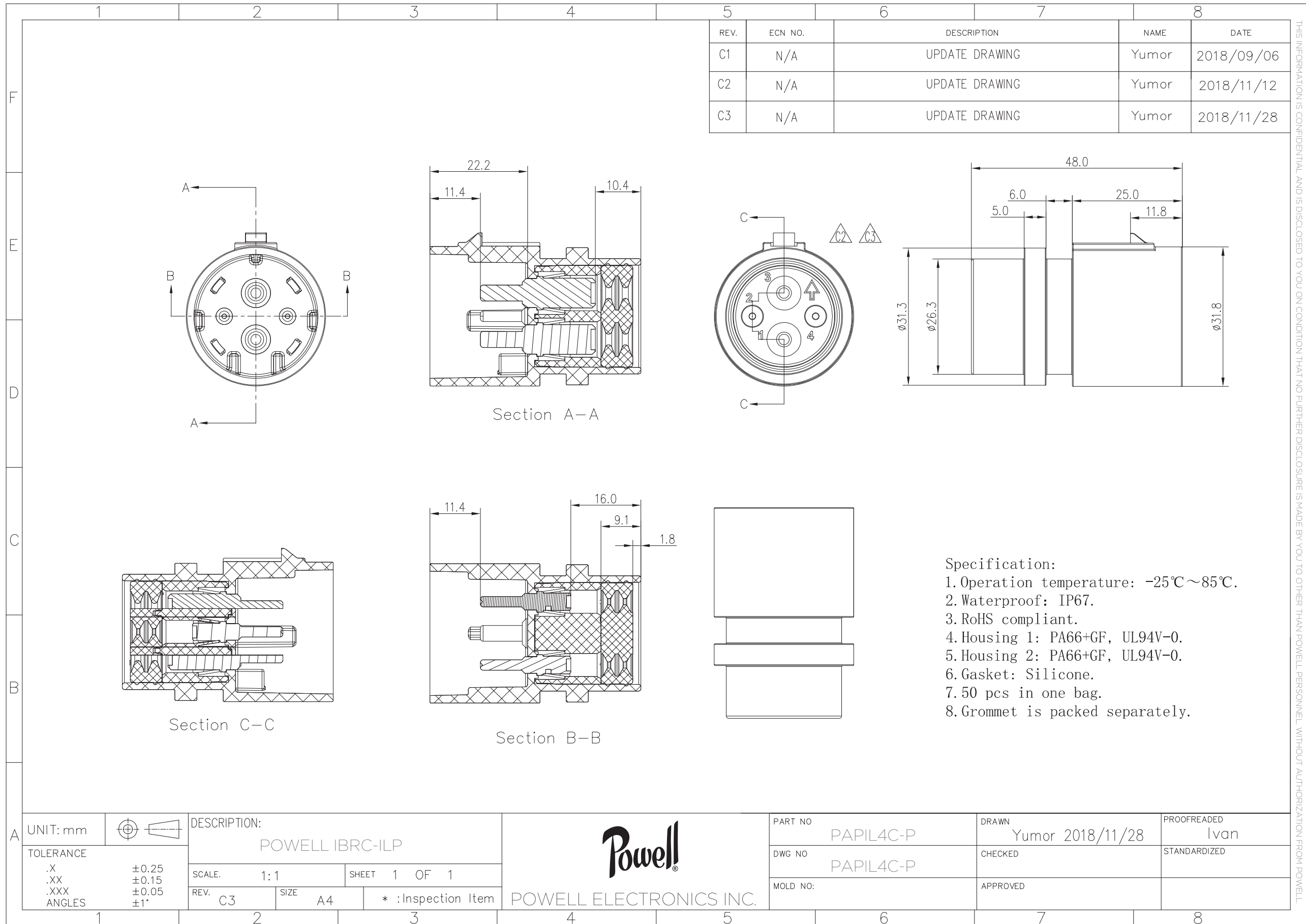

THIS INFORMATION IS CONFIDENTIAL AND IS DISCLOSED TO YOU ON CONDITION THAT NO FURTHER DISCLOSURE IS MADE BY YOU TO OTHER THAN POWELL PERSONNEL WITHOUT AUTHORIZATION FROM POWELL.

Appendix E

ISOBUS Relay Technical Drawing

REVISIONS			
REV	DESCRIPTION	DATE	APPROVED

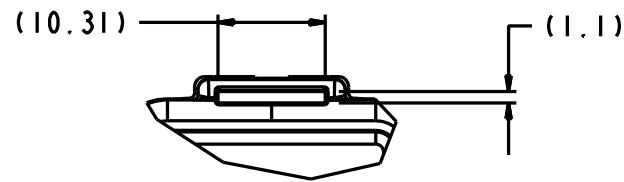
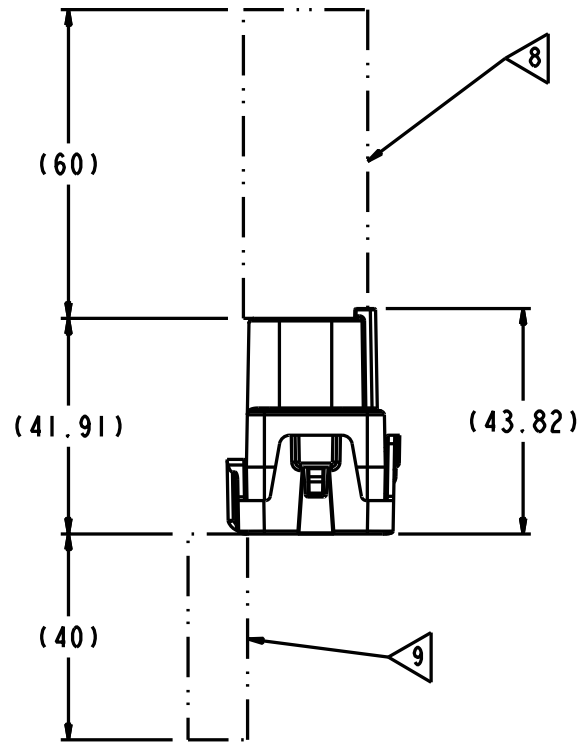

DETAIL A
SCALE 2:1

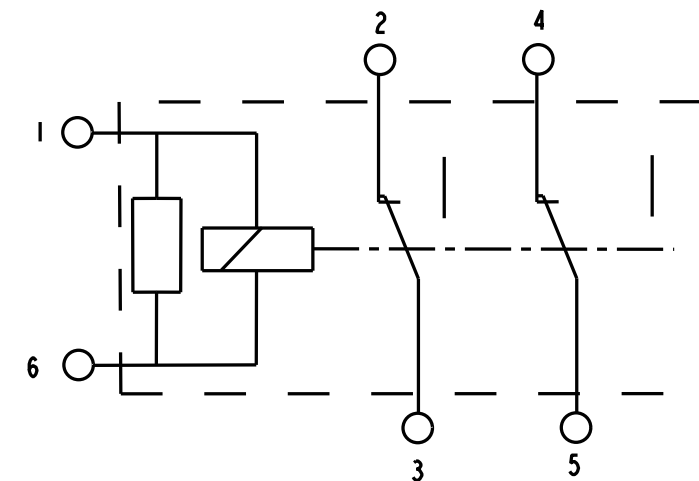
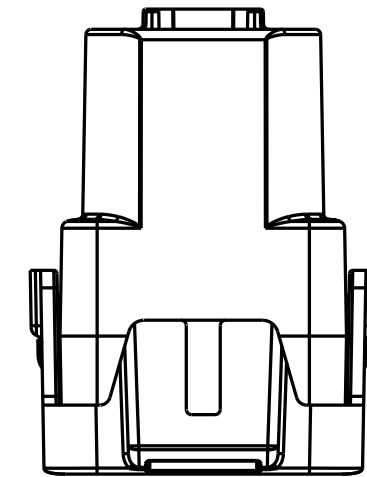
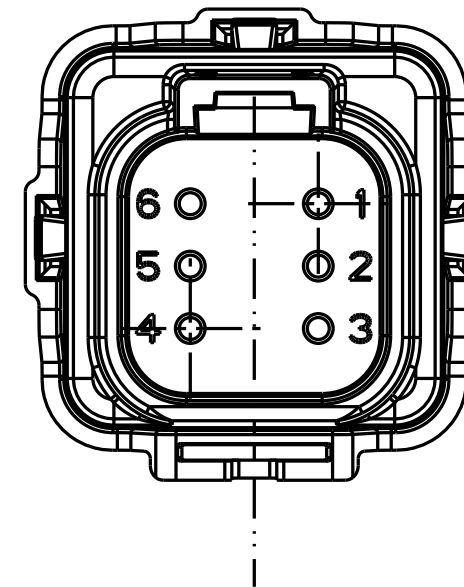
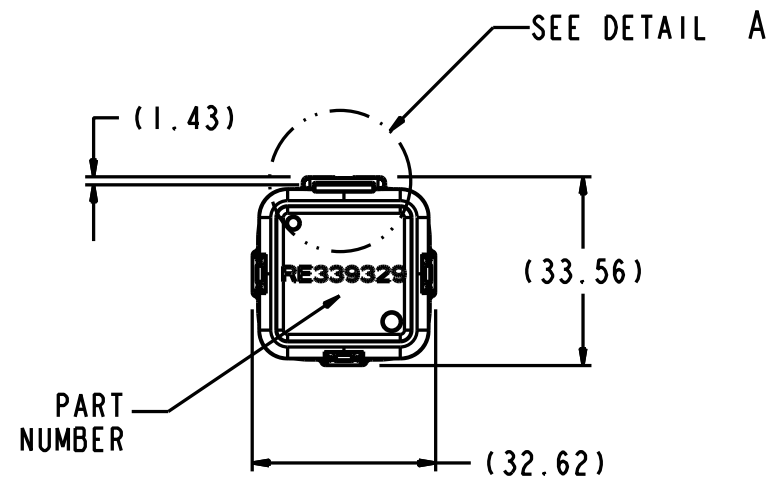

- THE FOLLOWING DOCUMENTS APPLY:
PHOENIX INTERNATIONAL P/N: 90-217188-XX
RE339329A ISOBUS RELAY ASSEMBLY
R339330A SCHEMATIC DIAGRAM
R339331A HARDWARE REQUIREMENTS
- THE AUTHORITY FOR ASSEMBLY CONTENT IS THE RELEASED BILL OF MATERIAL (BOM). REFER TO THE BOM FOR ASSEMBLY CONTENT AND DETAIL PART NUMBER REVISION LEVEL.
- THE AUTHORITY FOR EACH PART IS THE DETAIL PART DRAWING. REFER TO THE DETAIL PART DRAWING AND DATASET (AS APPLICABLE) FOR COMPLETE DETAIL PART DEFINITION.
- OPERATING TEMPERATURE RANGE: -40°C TO 85°C AMBIENT AIR TEMPERATURE. STORAGE TEMPERATURE RANGE: -55°C TO 105°C.
- THIS ISOBUS RELAY MUST BE MOUNTED USING BRACKET P/N: L171800 OR SIMILAR TO REDUCE VIBRATION.
- PRODUCTION MATING CONNECTOR IS:
DEUTSCH RECEPTACLE DT06-6S
- ISOBUS RELAY NOT TO BE MOUNTED WITH THE CONNECTOR FACING UP WHICH MAY CAUSE MOISTURE TO COLLECT AROUND CONNECTOR.

8 CLEARANCE NEEDED TO CONNECT MATING HARNESSSES.

9 CLEARANCE NEEDED TO CONNECT MOUNTING BRACKET.

- THE MATING CONNECTOR MUST BE CONNECTED TO THE ISOBUS RELAY FOR IT TO RESIST CHEMICAL INTRUSION AND FOR IT TO RESIST WATER INTRUSION FROM SPRAY OR IMMERSION.

11. MATING CONNECTOR PINOUT:

- PIN 1 = COIL+
- PIN 2 = CAN1L
- PIN 3 = CAN2L
- PIN 4 = CAN1H
- PIN 5 = CAN2H
- PIN 6 = COIL-

UNLESS OTHERWISE SPECIFIED ALL DIMENSIONS ARE INCHES [MM] TOLERANCES: EXCEPT AS NOTED INCHES HOLES .X ± .10 Ø.X ± .10 .XX ± .020 Ø.XX ± .015 .XXX ± .015 Ø.XXX ± .010	DESIGN ACTIVITY:		POWELL ELECTRONICS 200 Commodore Drive Swedesboro, NJ 08085	
	DATE	04-30-2012		
THIS DRAWING CONTAINS INFORMATION THAT IS PROPRIETARY AND SHOULD NOT BE USED WITHOUT PRIOR WRITTEN PERMISSION FROM POWELL ELECTRONICS	PREPARED	VS	SIZE	CAGE CODE
	CHECKED	RW	20441	DRAWING NO.
	ENGINEER	RM	RE339329	REV
APPROVED			SCALE NTS	SHEET 1 OF 1

Appendix G

Dual Beam Radar Mounting Kit Technical Drawing

