



BUILDING AUTOMATION SYSTEMS

Pressure | Temperature | Air Quality | Flow | Level | Process Control

dwyer-inst.com



The **trusted leader** in manufacturing innovative instrumentation solutions for the **worldwide** HVAC and process automation markets

CUSTOMER SATISFACTION

Meet and exceed customer and market expectations

INNOVATIVE

Sustained R&D and product development

COMPETITIVE

Highly automated and flexible manufacturing capabilities

TRUSTED

High-quality, reliable, and readily available products and solutions

GLOBAL SUPPORT

Global sales and marketing presence

ESTABLISHED DWYER BRANDS



DWYER AROUND THE GLOBE

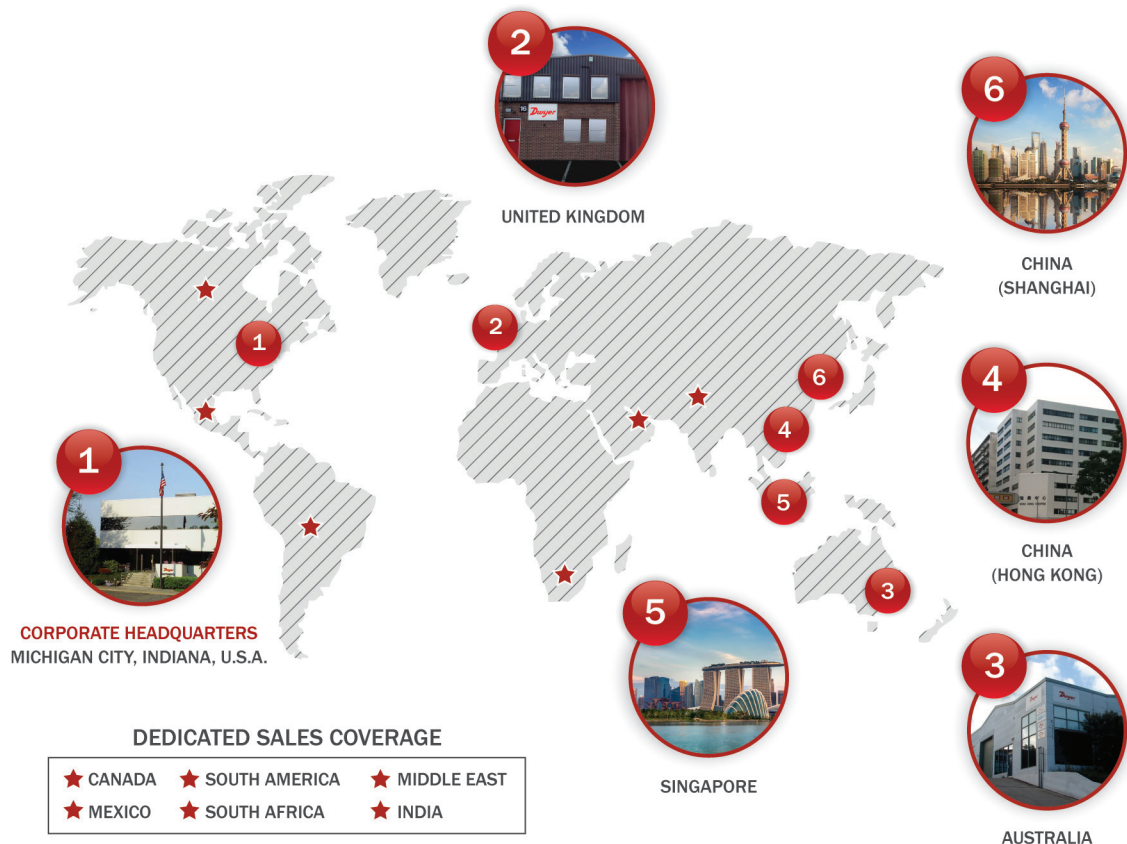

CONTACT INFORMATION

CORPORATE HEADQUARTERS

DWYER INSTRUMENTS, INC.
102 Indiana Highway 212
P.O. Box 373
Michigan City, IN 46360, U.S.A.

DWYER-INST.COM

Phone | (219) 879-8000
Toll-Free | (800) 872-9141
Fax | (219) 872-9057

UNITED KINGDOM

DWYER INSTRUMENTS LTD
Unit 16, The Wye Estate, London Road
High Wycombe, Bucks HP11 1LH-U.K.

DWYER-INST.CO.UK

Phone | +44 (0) 1494 461707
Fax | +44 (0) 1494 465102

AUSTRALIA

DWYER INSTRUMENTS, PTY. LTD.
Unit 1, 11 Waverley Drive
P.O. Box 359
Unanderra, NSW 2526 Australia

DWYER-INST.COM.AU

Phone | +61 (0) 2 4272 2055
Fax | +61 (0) 2 4272 4055

HONG KONG

DWYER INSTRUMENTS HK, LTD.
Unit 605A, 6/F, Shui Hing Centre
13 Sheung Yuet Road,
Kowloon Bay, Hong Kong

DWYER-INST.COM.HK

Phone | +852-23181007
Fax | +852-27561565

OTHER CONTACTS

ORDERS

orders@dwyermail.com

TECHNICAL SUPPORT

tech@dwyermail.com

LITERATURE REQUESTS

lit@dwyermail.com

QUOTATION/BID REQUESTS

quotes@dwyermail.com

GENERAL INFORMATION

info@dwyermail.com

INTERNATIONAL CUSTOMERS

Dwyer has local distributors in over 79 countries. Contact the office of your country or contact the corporate headquarters to find your local distributor. You can also go to our website at the following address to be contacted by your local distributor: dwyer-inst.com/Distributor

ABOUT US

Since the company was founded in 1931, customers have come to recognize Dwyer Instruments, Inc. to stand for quality, reliability, and readily available competitively priced products. As a leading manufacturer in the controls and instrumentation industry, we continue to grow and serve major markets including, but not limited to: HVAC, chemical, agriculture, food, oil and gas, water, wastewater, powder and bulk, and pollution control.

Dwyer holds over 650 technical patents and that number grows every year. We are an enthusiastic group of people headquartered in Michigan City, Indiana, with satellite locations around the globe. We take great pride in the intellect and integrity of our employees, who are passionate about the work we do, the products we develop, and the industries we serve.

MANUFACTURING EXCELLENCE

At Dwyer, it all starts with commitment to meeting the needs of our customers. We strive to make dependable, easy-to-use products.

With nearly 90 years of manufacturing expertise, we stand behind our high quality products. Dwyer products are trusted in applications all over the world in nearly every industry.

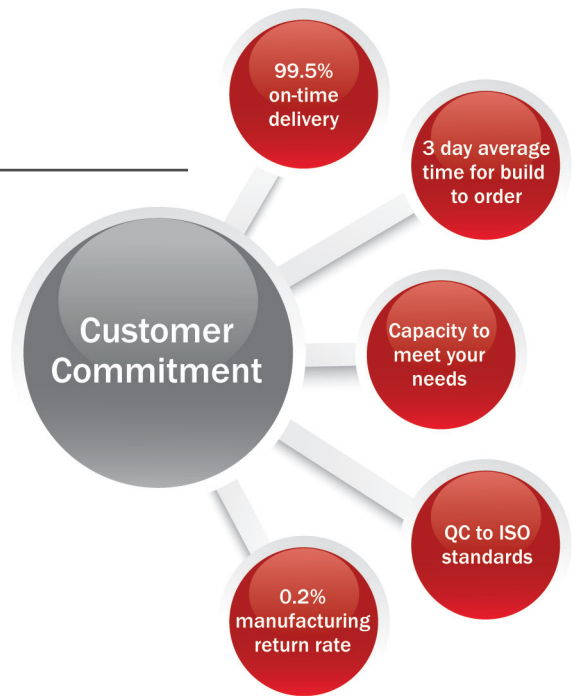

MANUFACTURING & DESIGN CENTER LOCATIONS

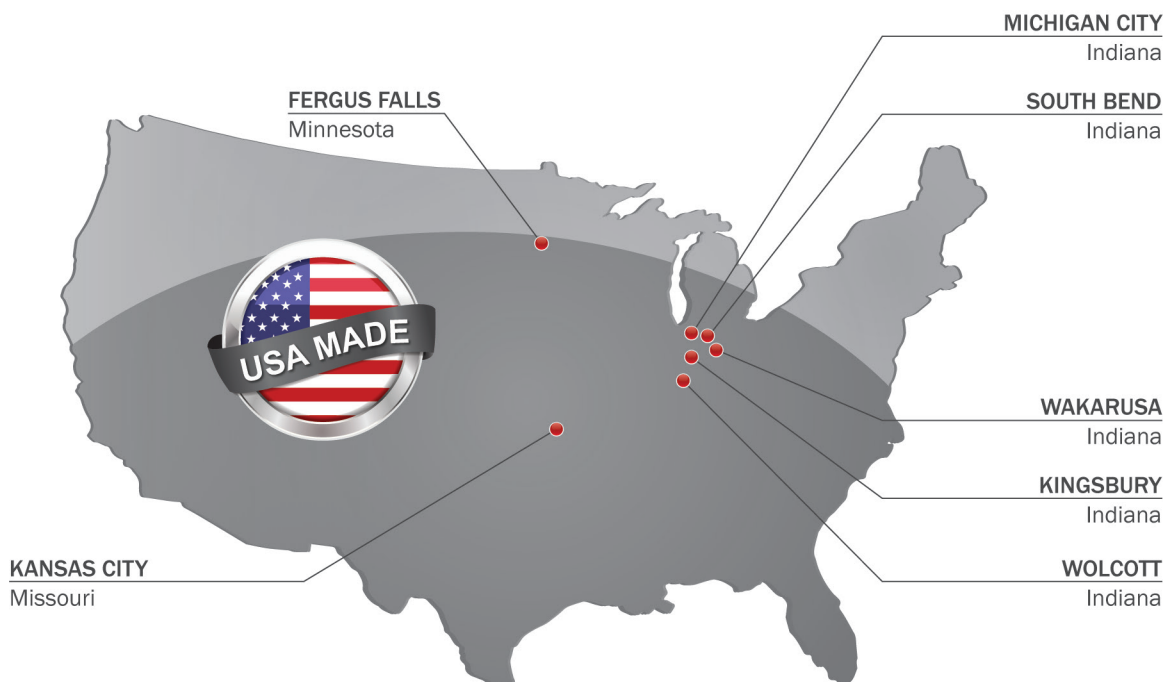

OUR PEOPLE MAKE THE DIFFERENCE

CUSTOMER SERVICE

CUSTOMER CARE

Courteous and professional customer service representatives are available via phone and email to process and provide assistance with your order. Dwyer provides industry leading response time to answer your call quickly without waiting.

PRICING

Contact us for formal quotes. Dwyer offers bids and project quotes. Discounts are available for particular customer types based on quantities purchased.

PRODUCT DELIVERY

LARGE INVENTORY LOCATED CENTRALLY IN THE U.S.A.

Dwyer is committed to process and ship your order as quickly as possible, with more than 5,000 items stocked in our South Bend, Indiana warehouse. In most cases lead time is less than one week for non-stocked products.

FAST PROCESSING & PACKING

Our dedicated shipping staff packs and ships your order same day on stocked items ordered before 1:00 PM U.S. Eastern Time.

FLEXIBLE SHIPPING

Dwyer offers blanket orders for OEMs to schedule out your product shipments for when you need them. Contact us for details.

TECHNICAL SUPPORT

All of our technical sales staff members are degreed engineers trained to be product and industry experts. We listen to your needs and get you the answers you want quickly.

WE HELP YOU FIND A SOLUTION

- Product Selection
- Application Assistance
- Regulatory and Agency Approval Compliance
- Installation Guidance
- Maintenance and Repair
- Product Customization for OEMs

TO CONTACT AN APPLICATIONS ENGINEER

PHONE: (219) 879-8000 | FAX: (219) 872-9057 | EMAIL: tech@dwyermail.com

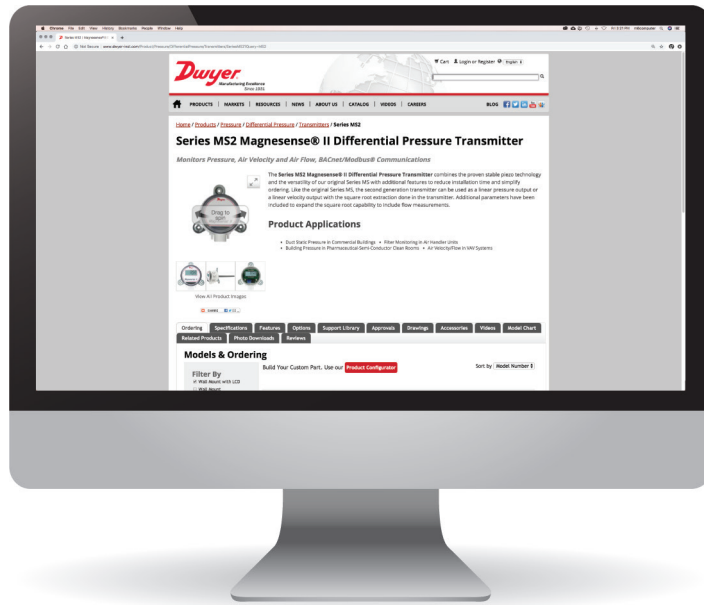

DWYER ONLINE

WEBSITE FEATURES

- Product Search
- Free Literature – Catalogs, Brochures and Product Selection Guides
- Product Application and Technical Guides
- Digital Catalogs
- Dedicated Support Product Pages
- Video Library

PRODUCT PAGE FEATURES

- Easy Online Ordering
- Product Support Library – Instruction Manuals, Catalog Pages and Data Sheets
- Product Configurator – Customize a Dwyer product to your specific application needs
- Agency Approval Certificates – CE, IECEx, FM, UL, CSA and ATEX
- Instructional and Informational Videos
- Product Drawings and Photography

DWYER CATALOG APP

Browse the Dwyer catalog online or download it for instant access offline. The Dwyer Catalog App is available in the iTunes® and Google Play™ stores.



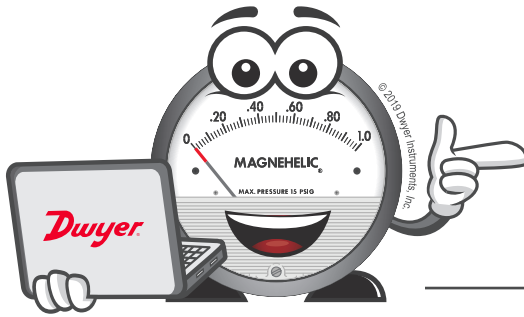

RELEASE A LITTLE PRESSURE BY **ORDERING ONLINE!**

- Save time, save money
- Repeat quick orders
- Receive special incentives

DID YOU KNOW, YOU CAN...

REVIEW PREVIOUS ORDERS

See a list of all previous orders for the past year, and sort by PO number, order number or confirmation number. Quickly obtain order shipping dates and tracking information for any specific order.

REVIEW PREVIOUS PRODUCT PURCHASES

Create quotes online that can be easily printed, emailed or converted to an order. Quotes are valid for 60 days, and are stored for 120 days.

CREATE PROJECTS

Create and view stored projects for up to three years. Projects can later be easily converted into a quotation.

STAY CONNECTED



Stay connected with Dwyer Instruments, Inc. throughout the year.

Our social media platforms allow you to stay up-to-date on Dwyer happenings and product offerings.

Visit us at: [dwyer-inst.com/social](https://www.dwyer-inst.com/social)

DWYER BLOG

Constantly expanding, consistently informative, the Dwyer Instruments, Inc. blog brings the latest HVAC and Process Automation market news to your desktop, tablet, or mobile device. The Dwyer executive and product management teams strive to honestly and authentically provide customers with industry insights through thought leadership.

CALIBRATION & REPAIR SERVICES

NO TIME FOR DOWNTIME
FAST & ACCURATE CALIBRATION SERVICES
dwyer-inst.com/calibration-nist/

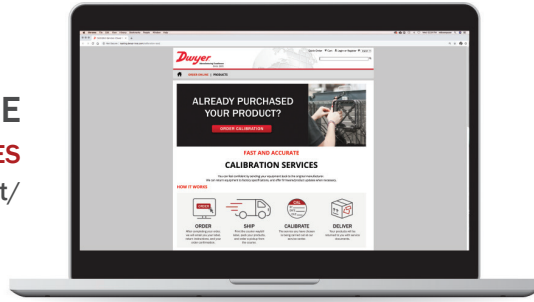

DEDICATED

Dwyer's dedication to quality is unmatched in the industry. We go above and beyond to provide impeccable service paired with quality calibrations.

COMMITTED

We understand being without your instrument can cost you money. We are committed to getting you your instrument back as fast as possible.

ACCURATE

You can feel confident by sending your equipment back to the original manufacturer.

SEE HOW IT WORKS



ORDER

Submit your online order and you'll receive a return label, instructions and confirmation.

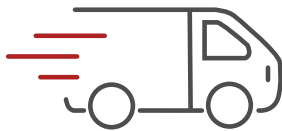

SHIP

Print the shipping label, pack your product(s) and send to Dwyer.



CALIBRATE

Monitor the status of your equipment through the entire calibration process.

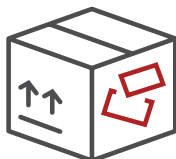

DELIVER

Once complete, your products and service documents will be shipped back to you.

CALIBRATION & REPAIR SERVICES

MARKET HIGHLIGHTS



PRESSURE

At Dwyer we understand that precise and accurate measurements are essential to our customers. Our pressure and vacuum calibrations will be performed with reliable and calibrated measuring and test equipment that is traceable to the SI through NIST.



FLUID & AIR FLOW

Why worry about the accuracy of your rotameter when you can send it straight to Dwyer Instruments? We do the work so that you can have peace of mind in knowing that a calibrated, reliable, and economically sound industrial flowmeter is installed at your location. Our flowmeters can be calibrated using various media, be it water or air.



VELOCITY & AIR FLOW

We calibrate the SMART Air Hood® Balancing Instrument in our facility using a state of the art wind tunnel (designed to satisfy the test requirements of the ISO 5167) to ensure your product is the most accurate on the market. We also calibrate our handheld anemometers!



TEMPERATURE & HUMIDITY

We strive to meet the crucial environmental precision measurement requirements of our customers. We offer fast, reliable, and affordable calibrations on our temperature and humidity transmitters that are designed to improve efficiency for you! You can customize the humidity and temperature outputs to satisfy your needs.

CERTIFICATE OF NIST CALIBRATION

A Certificate of NIST Calibration is available for most indicating and transmitting instrumentation products at an additional charge. This certificate is created in our testing lab to NIST traceable test instruments and includes test points with recorded data and the reference standard. Pricing and availability varies by product. Please consult the options listing for the product on the catalog page or see the product on our website for availability. For some products customer specified test points can be specified for an additional charge.

Customer Information		ID/Serial	Device Make and Model
Customer Name		000000	000000
Address		Type:	Thermal Anemometer
City		Description:	Air Velocity Measurement Device
State		MFG:	Dwyer Instruments
Zip		Model:	
Accuracy:		Serial:	
Unit:		Output 1:	
Output 2:		Output 2:	
Address Where Calibration Was Performed		Calibration Procedure	
Dwyer Instruments		Procedure:	
800 Highway 212		Reference:	As Found As Left
Michigan City, IN 46340		Test Range:	
Customer Reference Used		Note:	Final Case calibration and rig uncertainty: +/- 2% of reading
Variable	ID#	Last Cal	Due Date
		Temp:	°C 32.0 °F
		RH:	%RH
		Humidity:	g/kg
		Pressure:	MPa 0.0 bar(ga) (a)
As Found As Left Calibration Data (All values in)			
RESULT	Target Test Point	Calibration Standard Reading	DEV Reading (1) DEV Reading (2)
PASSED			Corrected to
PASSED			to
PASSED			to
PASSED			to
PASSED			to
PASSED			to
This document certifies that only the devices under test (DUT) identified above have been calibrated against a reference standard having a measurement uncertainty as listed. Uncertainty is given at a k=1 confidence interval.			
Calibrated By: _____		Job Function: _____	Technician: _____

STANDARD TERMS & CONDITIONS OF SALE

DWYER INSTRUMENTS, INC. - TERMS AND CONDITIONS OF SALE – MARCH 15, 2017

- 1. Prices and Specifications** are subject to change without notice.
- 2. Shipping dates** are approximate. They are dependent upon credit approval and subject to delays beyond our control.
- 3. Terms:** Net 30 days to companies with established credit rating. In the event Buyer fails to fulfill previous terms of payment, or in case Seller shall have any doubt at any time as to Buyer's financial responsibility, Seller may decline to make further deliveries except upon receipt of cash in advance or other special arrangements.
- 4. Point and Title:** All material is sold EXW Ex Works Dwyer Instruments, Inc. Title to all material sold shall pass to buyer upon delivery by Seller to carrier at shipping point.
- 5. State and Local Taxes:** Any taxes which the Seller may be required to pay or collect upon or with respect to the sale, purchase, delivery, use or consumption of any of the material covered hereby shall be for the account of the Buyer and shall be added to the purchase price.
- 6. Special tooling,** dies, silk screens and molds acquired specially to produce goods for Buyer remain the property of Dwyer Instruments, Inc., and may not be removed. They will be maintained in good condition for a minimum period of three years from the date of the original purchase order.
- 7. Trade Compliance:** Buyer acknowledges that the products, software, and technology, including technical information and documents (collectively "Items"), of Dwyer Instruments, Inc., are subject to regulation by agencies of the U.S. government including, but not limited to, the U.S. Department of Commerce. Buyer shall comply with the Export Administration Regulations (EAR) and all applicable U.S. laws and regulations regarding the sale, delivery and transfer of said Items. Buyer shall not, without first obtaining the required licenses, authorizations or approvals from the appropriate U.S. government agency; (i) export, re-export, transfer or divert any Item directly or indirectly to any country or national resident thereof, or any person, entity or country that has restrictions imposed upon them by the U.S. government, (ii) engage in, or knowingly sell to any party engaged in activity related to the development, production, use, testing, or maintenance of Weapons of Mass Destruction, including uses related to nuclear, missile, chemical or biological warfare, or (iii) engage in, or knowingly sell to any party engaged in activity related to the development, production, use, or maintenance of any safeguarded or unsafeguarded nuclear fuel facility or components for such facilities. Buyer shall fully cooperate with Seller, without charge, in any official audit or inspection by an authorized agent, official, employee, or accredited representative of the U.S. government. Buyer shall indemnify and hold Seller harmless from, or in connection with, any violation of this Section by Buyer, its employees, consultants, agents, or customers. The obligations, requirements and claims described herein shall survive the expiration of any business relationship with Dwyer Instruments, Inc., including its divisions, subsidiaries and affiliated companies.
- 8. Distribution:** Products sold to any entity located in the U.S. must remain in the U.S. unless a Global Distribution Agreement is in force with said entity. OEM's are excluded from this requirement. Those who violate this term are subject to a reduction of discount, loss of discount, or exclusion from purchasing future products. If you want to be a Global Distributor, please contact your Global Sales Manager in your region.
- 9. Limited Warranty:** The Seller warrants all Dwyer instruments and equipment to be free from defects in workmanship or material under normal use and service for a period of one year from date of shipment. Products qualifying for an extended warranty period will have the extended warranty as expressly indicated on the catalog page, web page, IOM, or will be covered by a specific written agreement that is (i) approved by an officer of Dwyer Instruments, Inc. and (ii) defines the warranty period. If no express statement of extended warranty is made, then the standard 1 year warranty applies. The Extended Limited Warranty only applies to products manufactured after April 1, 2017. The Warranty period extends from the date of shipment to the initial customer and not the project installation date or use.

Specific warranty exclusions include, but are not limited to:

- Specific product components not covered by the extended warranty:
 - o Humidity Sensors
 - o Batteries
 - o Electro-Chemical Gas Sensors
 - o Snap Switches
 - o Any component which exceed its normal life cycle
 - o Other Specific items added as required.
- Normal or excessive wear and tear is not cause for warranty replacement.
- Products not properly maintained, operated, installed, or use in an application not suited for the product.
- Modifications, alterations, changes, or additions outside those which are required for normal operation.
- Failure to notify Dwyer of any defect within a reasonable time.
- Damage which the customer has not taken timely action to minimize or mitigate.
- Products on which the labels, markings, nameplates, etc. have been tampered with.
- Products which contain broken factory seals or have been tampered with shall void warranty.

Liability under this warranty is limited to repair or replacement EXW Ex Works Dwyer Instruments, Inc. of any parts which prove to be defective within that time or repayment of the purchase price at the Seller's option. All products must be returned to the Seller, transportation prepaid, unless other arrangements have been pre-approved by Seller. All technical advice, recommendations and services are based on technical data and information which the Seller believes to be reliable and are intended for use by persons having skill and knowledge of the business, at their own discretion. In no case is Seller liable beyond replacement of equipment EXW Ex Works Dwyer Instruments, Inc. or the full purchase price. This warranty does not apply if the maximum ratings label is removed or if the instrument or equipment is abused, altered, used at ratings above the maximum specified, or otherwise misused in any way.

THIS EXPRESS LIMITED WARRANTY IS IN LIEU OF AND EXCLUDES ALL OTHER REPRESENTATIONS MADE BY ADVERTISEMENTS OR BY AGENTS AND ALL OTHER WARRANTIES, BOTH EXPRESS AND IMPLIED. THERE ARE NO IMPLIED WARRANTIES OF MERCHANTABILITY OR OF FITNESS FOR A PARTICULAR PURPOSE FOR GOODS COVERED HEREUNDER.

- 10. Buyer's Remedies:** THE BUYER'S EXCLUSIVE AND SOLE REMEDY ON ACCOUNT OF OR IN RESPECT TO THE FURNISHING OF NON-CONFORMING OR DEFECTIVE MATERIAL SHALL BE TO SECURE REPLACEMENT THEREOF AS AFORESAID. THE SELLER SHALL NOT IN ANY EVENT BE LIABLE FOR THE COST OF ANY LABOR EXPENDED ON ANY SUCH MATERIAL OR FOR ANY SPECIAL, DIRECT, INDIRECT, CONSEQUENTIAL OR INCIDENTAL DAMAGES TO ANYONE BY REASON OF THE FACT THAT IT SHALL HAVE BEEN NON-CONFORMING OR DEFECTIVE.
- 11. Acceptance:** All orders shall be subject to the terms and conditions contained or referred to in the Seller's quotation, acknowledgment, and to those listed here and to no others whatsoever. By placing an order you accept our terms and conditions. No waiver, alteration or modification of these terms and conditions shall be binding unless in writing and signed by an executive officer of the Seller. All orders are subject to written acceptance by Dwyer Instruments, Inc., Michigan City, Indiana, U.S.A.

1-28

PRESSURE

Magnesense® II Differential Pressure Transmitter | **MS2** 1
 Magnesense® Differential Pressure Transmitter | **MS** 2
 DigiHelic® 3 Differential Pressure Controllers | **DH3** 3
 DigiMag® Digital Differential Pressure and Flow Gage | **DM-1000** . 4
 Differential Pressure Transmitters | **DM-2000** 5
 Differential Pressure Transmitter | **616W** 6
 Differential Pressure Transmitter | **616WL** 6
 Magnehelic® Differential Pressure Gages | **2000** 7-8
 Magnehelic® Gage Options 9
 Magnehelic® Gage Mounting Accessories 10
 Instrument Enclosures | **A-320** 10
 Magnehelic® Differential Pressure Indicating Transmitter | **605** . 11
 Capsuhelic® Differential Pressure Gage | **4000** 12
 Photohelic® Switch/Gages | **3000MR & 3000MRS** 13
 DIN Rail Differential Pressure Transmitter | **616D** 14

TEMPERATURE

Wall Mount Temperature Sensors | **TE-E/N** 29
 Stainless Steel Wall Plate Temperature Sensor | **TE-WSS** 29
 Duct and Immersion Building Automation Temperature Sensors
TE 30
 Immersion Temperature Sensors | **TE-I** 31
 Thermowells | **TE-TNS** 31
 Outdoor Temperature Sensors | **TE-OND/TE-RND/TE-OSA** 32
 Averaging Temperature Sensor | **TE-A** 33

AIR QUALITY

Wall Mount Humidity/Temperature/Dew Point Transmitters
RHP-E/N 39
 Wall Mount Humidity/Temperature Transmitter | **RHPLC** 40
 Humidity/Temperature Transmitters | **RHP** 41
 Outside Air Humidity Radiation Shields | **RHRS** 42
 Weather-Resistant Humidity/Temperature Transmitter | **WHT** . . . 42
 Humidity/Temperature Transmitter | **RH-R** 43
 Relative Humidity/Temperature Transmitters | **657** 43
 Carbon Dioxide/Temperature Transmitters | **CDT** 44
 Communicating Carbon Dioxide Detectors | **CDTA** 45
 Carbon Dioxide/RH/Temperature Transmitters | **CDTR** 46
 Carbon Dioxide/Volatile Organic Compound Transmitters
CDTV 47
 Carbon Dioxide Transmitter | **CDWP** 48
 Occupancy Sensors | **OSC-200 & OSW-100** 48
 Carbon Monoxide/Nitrogen Dioxide Gas Transmitters
GSTA & GSTC 49

FLOW

Insertion Thermal Energy Meter | **IEFB** 61-62
 Remote Display for Series IEF and IEFB | **A-IEF** 62
 Insertion Electromagnetic Flow Transmitter | **IEF** 63
 Ultrasonic Energy Meters | **TUF** 64
 Paddlewheel Flow Sensor | **PFT** 65
 Multi-Jet Hot Water Meter | **WMH** 66
 Multi-Jet Brass Body Water Meter | **WNT** 66

LEVEL

Water Leak Detectors | **WD3** 72
 Water Detector and Sensor Tape | **WD** 72
 Cable Float Switch | **CFS2** 73
 Flotect® Liquid Level Switches | **L8** 73
 Level Switches - Horizontal/Specialty | **F6 & F7** 74

PROCESS CONTROL

Miniature Current Switches | **MCS** 79
 Current Switches | **CCS** 79
 Miniature Current Switches | **MSCS** 80
 Sure-Set Current Switches | **SSCS** 80
 Current Switches | **SCS** 81
 Current Transformers | **CCT40/50** 82
 True RSM Current Transformers | **CCT60/70** 82
 Low Cost DC Power Supply | **BPS-005** 83
 Low Cost DC Power Supply | **BPS-015** 83
 Power Supply | **A-700** 83

ACCESSORIES

Static Pressure Tips 92
 Accessories - Kits for Air Filter Switches 92

Differential Pressure Transmitters ±0.25, ±1, or ±2% Accuracy
616KD 15
 Differential Pressure Transmitters - Low Ranges | **616KD-LR** 16
 Wet/Wet Differential Pressure Transmitter | **647** 17
 Wet/Wet Differential Pressure Switch | **DX** 18
 Compact Differential Pressure Transmitters | **668B/D** 19
 HVAC Differential Pressure Switches
ADPS/EDPS/BDPA/BYDS 20
 Compact Low Differential Pressure Switches | **1900** 21
 DPDT Low Differential Pressure Switches | **1831** 22
 Wet/Wet Differential Pressure Transmitters | **645** 22
 Differential Pressure Transmitters | **629HLP** 23
 Wet/Wet Differential Pressure Transmitters | **629C** 24
 Smart Differential Pressure Transmitter | **3500** 25-26
 Industrial Pressure Transmitters | **626 & 628** 27-28

Outside Air Temperature Sensor | **O-4** 33
 Weather Resistant Surface Temperature Sensor | **TE-SNW** 34
 Surface Mount Temperature Sensor | **S2-1** 34
 Temperature Transmitter | **BTT-E/N** 35
 Temperature Transmitters | **BTT** 36
 Weatherproof Immersion Temperature Transmitter | **TTW** 37
 Temperature Transmitter | **TBU-00** 37
 Explosion-Proof RTD Temperature Transmitter | **TTE** 38

Carbon Monoxide Transmitters | **CMT200** 50
 Carbon Monoxide Transmitter and Switch | **CMS300** 50
 Duct Smoke Detector | **SL-2000** 51
 Air Velocity Transmitters | **AVUL** 52
 Air Velocity Transmitter | **AVLV** 53
 Pencil Style Air Velocity Transmitter | **AVPT** 54
 Air Velocity Transmitters | **641** 55
 Air Flow Switch | **AVFS** 56
 Adjustable Air Flow Paddle Switch | **AAFS** 56
 Fume Hood Monitor | **670** 57
 Averaging Flow Grid | **AFG** 57
 Metal Averaging Flow Sensor | **MAFS** 58
 Averaging Flow Sensors | **PAFS-1000** 58
 Duct Mounted Airflow Measurement Stations | **FLST** 59
 Duct Mounted Airflow Measurement Stations | **STRA** 60

Ultrasonic Flowmeter Sets | **UFB & UFC** 67
 Compact Ultrasonic Flowmeters | **UFM** 68
 Ultrasonic Thickness Gage | **UTG** 68
 Vane Flow Switch | **FS-2** 69
 Flotect® Vane Operated Flow Switch | **V7** 70
 Flotect® Mini-Size Flow Switch | **V10** 70
 Flotect® Vane Operated Flow Switches | **V8** 71

Submersible Level Transmitters | **SBLT2 & SBLTX** 75
 Submersible Level Transmitters | **PBLT2 & PBLTX** 76
 Ultrasonic Level Transmitter | **ULT** 77
 Ultrasonic Level Sensors | **ULSS, ULSM & ULSL** 78

AC Power Transformers | **APT** 84
 Graphical User Interface Panel Meter | **SPPM2** 85
 Smart Programmable Panel Meters | **SPPM** 86
 LCD Digital Panel Meters | **DPMA, DPMW, DPMP, & DPML** 87
 Extra Large Digital Panel Meter | **DPMX** 88
 Compact Process Indicator | **LCI32** 88
 Electromechanical Relays | **9** 89
 Ice Cube Relays | **781 & 782** 89
 Galvannealed Steel Enclosures | **CSE-3R** 90
 Carbon Steel Enclosures | **CSE-N1 & CSE-KN** 91

Static Pressure Accessories 93
 Gage Tubing Accessories 93

29-38

39-60

61-71

72-78

79-91

92-93

AIR HANDLER

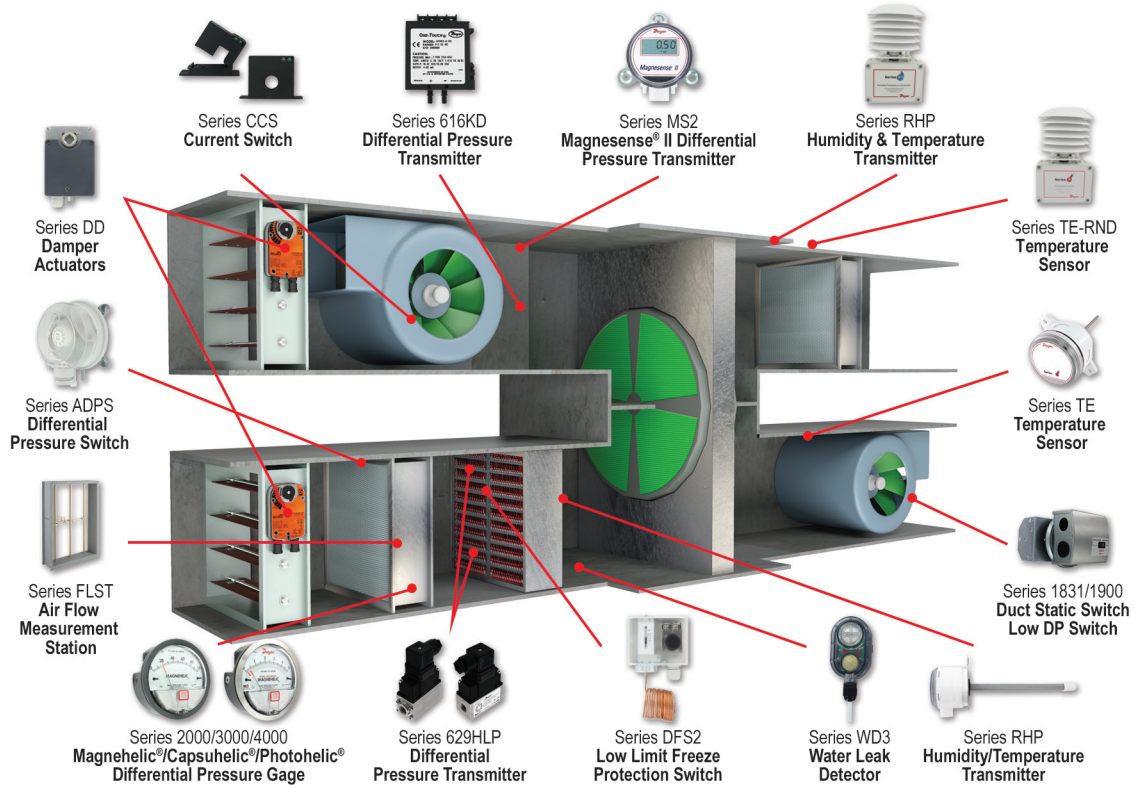

TERMINAL UNIT

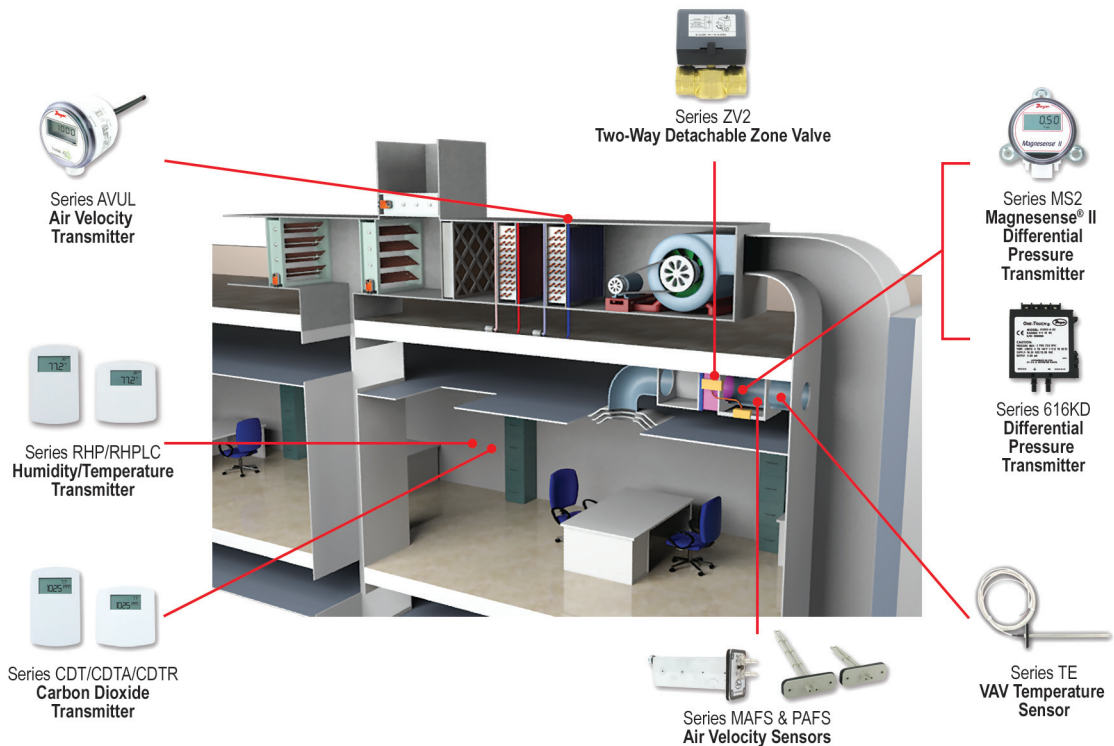

CHILLER PLANT

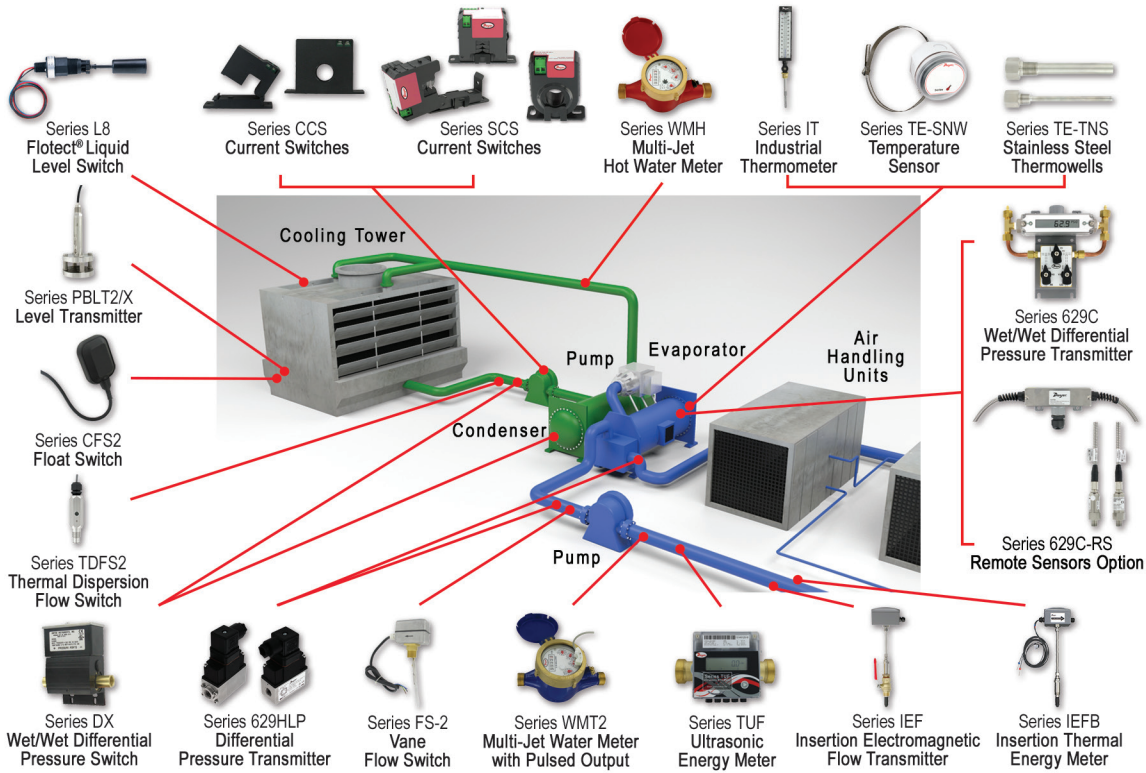

CLEAN ROOM

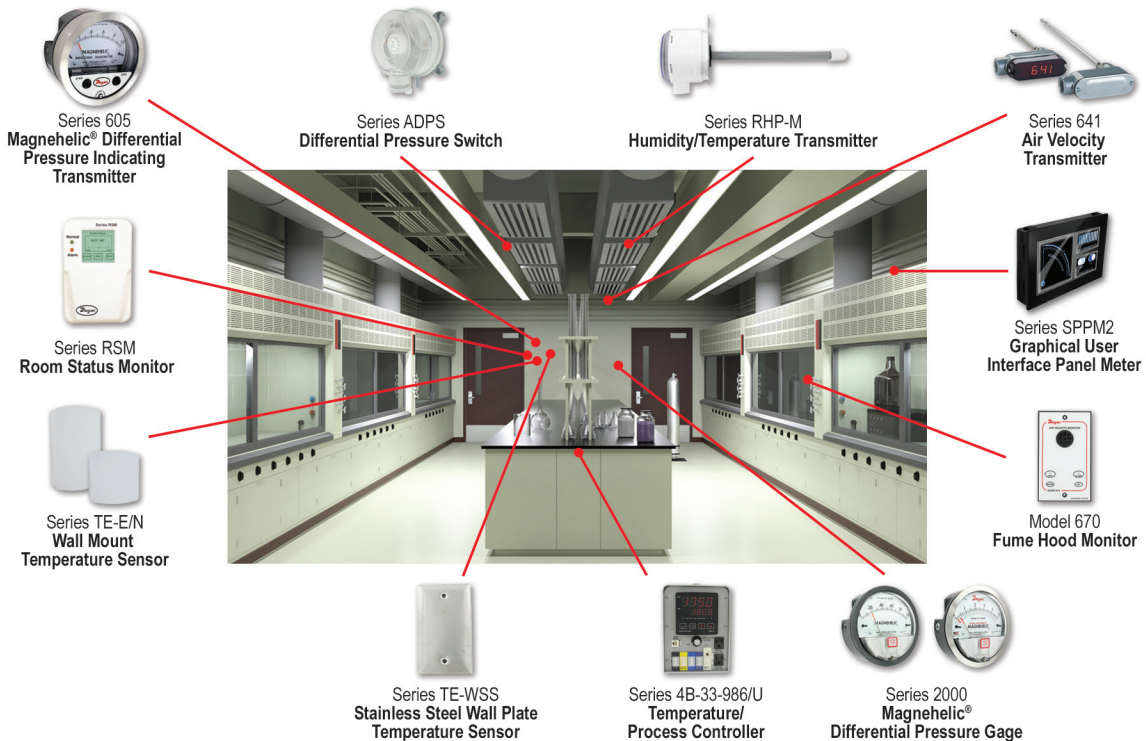

MAGNESENSE® II DIFFERENTIAL PRESSURE TRANSMITTER

Monitors Pressure, Air Velocity and Air Flow, BACnet or Modbus® Communications

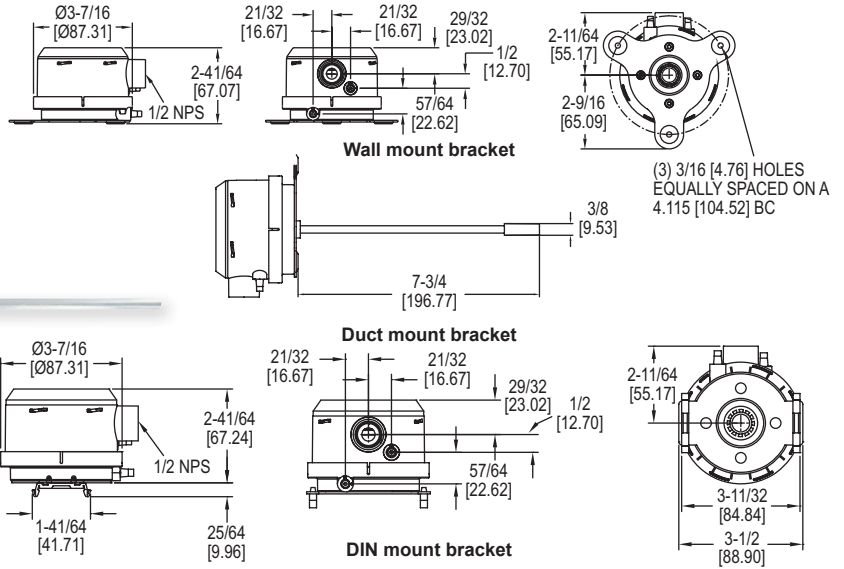
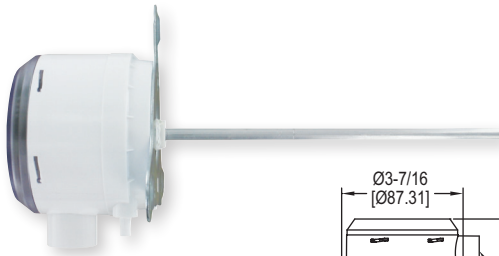

The Series MS2 Magnesense® II Differential Pressure Transmitter combines the proven stable piezo technology and the versatility of our original Series MS with additional features to reduce installation time and simplify ordering. Like the original Series MS, the second generation transmitter can be used as a linear pressure output or a linear velocity output with the square root extraction done in the transmitter. Additional parameters have been included to expand the square root capability to include flow measurements.

FEATURES/BENEFITS

- Field selectable ranges and output signal reduce inventory and the chances of ordering an incorrect part
- BACnet or Modbus® serial communications reduce wiring cost by daisy-chaining the transmitters
- Our integral field-upgradeable display or plug-in remote display tool save upfront material cost and allow for local viewing of measurements

APPLICATIONS

- Filter monitoring in air handler units
- Building pressure in pharmaceutical-semiconductor clean rooms
- Duct static pressure in commercial buildings
- Air velocity/flow in VAV systems

SPECIFICATIONS

Supported Baud Rates: 9600, 19200, 38400, 57600, 76800, 115200.
Data Size: 8.
Parity: None.
Stop Bits: 1.
Service: Air and non-combustible, compatible gases.
Wetted Materials: Consult factory.
Typical Accuracy: ±1% FS for 0.15 in w.c. (40 Pa), 0.25 in w.c. (50 Pa), 0.5 in w.c. (125 Pa), 2 in w.c. (500 Pa), 3 in w.c. (750 Pa), 5 in w.c. (1250 Pa), 10 in w.c. (2 kPa), 15 in w.c. (3 kPa), 25 in w.c. (5 kPa), 28 in w.c. (6.975 kPa); ±2% FS for 0.1 in w.c. (25 Pa), 1 in w.c. (250 Pa), and all bi-directional ranges.
Stability: ±1% / year FSO.
Temperature Limits: 0 to 150°F (-18 to 66°C).
Pressure Limits: 1 psi max., operation; 10 psi burst.
Power Requirements: 10-35 VDC (2-wire), 17-36 VDC or isolated 21.6-33 VAC (3-wire).
Output Signals: 4-20 mA (2-wire), 0-5 VDC, 0-10 VDC (3-wire).
Response Time: Adjustable: 0.5 to 15 sec. time constant. Provides a 95% response time of 1.5 to 45 seconds.
Zero & Span Adjustments: Digital push-buttons.
Loop Resistance: Current output: 0 to 1250 Ω max; Voltage output: Min. load resistance 1 kΩ.
Current Consumption: 40 mA max.
Display (Optional): 5 digit LCD.
Electrical Connections: 3-wire removable European style terminal block for 16 to 22 AWG.
Electrical Entry: 1/2" NPS thread.
Process Connection: 3/16" ID tubing (5 mm ID); Max. OD 9 mm.
Enclosure Rating: IP66.
Mounting Orientation: Not position sensitive.
Weight: 8.0 oz (230 g).
Agency Approvals: BTL, CE.

MODEL CHART

Model	in w.c.	Pa	mm w.c.	kPa
MS2-W101	0.10, 0.15, 0.25, 0.50	25, 40, 50, 125	2.5, 4, 6, 10	0.025, 0.04, 0.05, 0.125
MS2-W111	±0.10, ±0.15, ±0.25, ±0.50	±25, ±40, ±50, ±125	±2.5, ±4, ±6, ±10	±0.025, ±0.04, ±0.05, ±0.125
MS2-W102	1, 2, 3, 5	250, 500, 750, 1250	25, 50, 75, 125	0.25, 0.5, 0.75, 1.25
MS2-W112	±1, ±2, ±3, ±5	±250, ±500, ±750, ±1250	25, 50, 75, 125	0.25, 0.5, 0.75, 1.25
MS2-W103	10, 15, 25, 28	2500, 3500, 5000, 6975	250, 350, 500, 697.5	2.5, 3.5, 5.0, 6.975
	±10, ±15, ±25, ±28	±2500, ±3500, ±5000, ±6975	±250, ±350, ±500, ±697.5	±2.5, ±3.5, ±5.0, ±6.975

Note: For duct mount static probe change W to D. **Example:** MS2-D101
 For DIN rail mounting change W to N. **Example:** MS2-N101

OPTIONS

To order add suffix:	Description
-LCD	Units with display
Example: MS2-W101-LCD	
-BC	BACnet Communications
Example: MS2-W101-BC	
-MC	Modbus® Communications
Example: MS2-W101-MC	
-NIST	NIST traceable calibration certificate
Example: MS2-W101-NIST	
-FC	Factory calibration certificate
Example: MS2-W101-FC	

ACCESSORIES

Model	Description
A-151	Cable gland for 5 to 10 mm diameter cable
A-MS2-LCD	Field upgradeable display
A-435-A	Remote display tool
A-480	Plastic static pressure tip
A-481	Installer kit; includes 2 plastic static pressure tips and 7 ft (2.1 m) of PVC tubing
A-489	4" 303 SS straight static pressure tip with flange
A-302F-A	4" 303 SS static pressure tip with mounting flange; for 3/16" ID rubber or plastic tubing
SCD-PS	100-240 VAC/VDC to 24 VDC power supply

Modbus® is a registered trademark of Schneider Automation, Inc.
 Process Tubing Options: See page 93 (Gage Tubing Accessories)

MAGNESENSE® DIFFERENTIAL PRESSURE TRANSMITTER

Monitors Pressure and Air Velocity



Standard MS with optional LCD

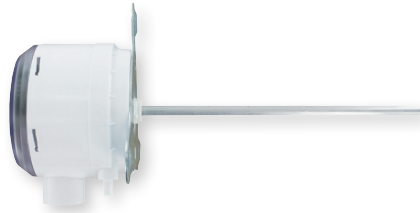
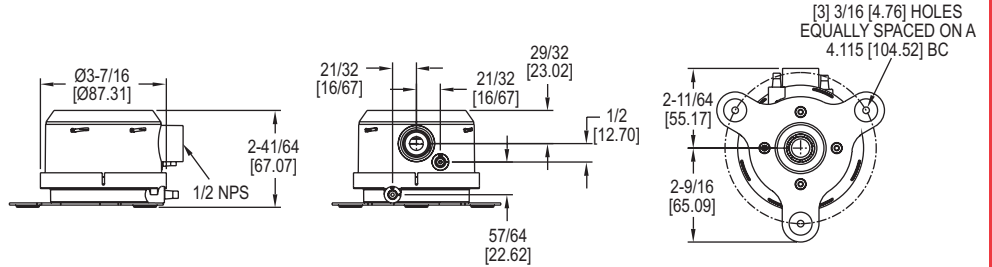

MS with optional LCD and static probe

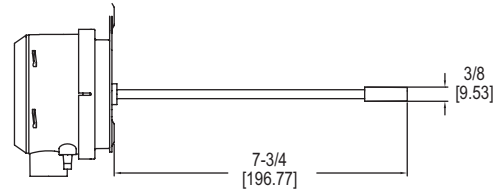

The Series MS Magnesense® Differential Pressure Transmitter is an extremely versatile transmitter for monitoring pressure and air velocity. This compact package is loaded with features such as:

FEATURES/BENEFITS

- Field selectable English or Metric ranges
- Field upgradeable LCD display
- Adjustable damping of output signal (with optional display)
- Ability to select a square root output for use with pitot tubes and other similar flow sensors

APPLICATIONS

- Building pressure monitoring
- Duct pressure monitoring
- Fan velocity measurement
- Zone differential pressure monitoring
- Filter condition monitoring

Along with these features, the patented magnetic sensing technology provides exceptional long term performance and enables the Magnesense® Differential Pressure Transmitter to be the single solution for your pressure and flow applications.

SPECIFICATIONS

Service: Air and non-combustible, compatible gases.	Zero & Span Adjustments: Digital push-button.
Wetted Materials: Consult factory.	Loop Resistance: Current output: 0-1250 Ω max; Voltage output: min. load resistance 1 kΩ.
Accuracy: ±1% for 0.25" (50 Pa), 0.5" (100 Pa), 2" (500 Pa), 5" (1250 Pa), 10" (2 kPa), 15" (3 kPa), 25" (5 kPa); ±2% for 0.1" (25 Pa), 1" (250 Pa) and all bi-directional ranges.	Current Consumption: 40 mA max.
Stability: ±1% FS/year.	Display (optional): 4 digit LCD.
Temperature Limits: 0 to 150°F (-18 to 66°C).	Electrical Connections: 4-20 mA, 2-Wire: European style terminal block for 16 to 26 AWG; 0-10 V, 3-Wire: European style terminal block for 16 to 22 AWG.
Pressure Limits: 1 psi maximum, operation; 10 psi, burst.	Electrical Entry: 1/2" NPS thread; Accessory (A-151): Cable gland for 5 to 10 mm diameter cable.
Power Requirements: 10-35 VDC (2-wire); 17-36 VDC or isolated 21.6-33 VAC (3-wire).	Process Connections: 3/16" (5 mm) ID tubing. Maximum OD 9 mm.
Output Signals: 4-20 mA (2-wire); 0-5 V, 0-10 V (3-wire).	Enclosure Rating: NEMA 4X (IP66).
Response Time: Adjustable 0.5 to 15 s time constant. Provides a 95% response time of 1.5 to 45 seconds.	Mounting Orientation: Diaphragm in vertical position.
	Weight: 8.0 oz (230 g).
	Agency Approvals: CE.

MODEL CHART		
Model	Output	Selectable Ranges
MS-121*	4-20 mA	0.1 in, 0.25 in, 0.5 in w.c. (25, 50, 100 Pa)
MS-321*	0-10 V	0.1 in, 0.25 in, 0.5 in w.c. (25, 50, 100 Pa)
MS-721*	0-5 V	0.1 in, 0.25 in, 0.5 in w.c. (25, 50, 100 Pa)
MS-111*	4-20 mA	1 in, 2 in, 5 in w.c. (250, 500, 1250 Pa)
MS-311*	0-10 V	1 in, 2 in, 5 in w.c. (250, 500, 1250 Pa)
MS-711*	0-5 V	1 in, 2 in, 5 in w.c. (250, 500, 1250 Pa)
MS-131	4-20 mA	10 in w.c. (2 kPa)
MS-141	4-20 mA	15 in w.c. (3 kPa)
MS-151	4-20 mA	25 in w.c. (5 kPa)
MS-331	0-10 V	10 in w.c. (2 kPa)
MS-341	0-10 V	15 in w.c. (3 kPa)
MS-351	0-10 V	25 in w.c. (5 kPa)
MS-021	4-20 mA	±0.1 in, 0.25 in, 0.5 in w.c. (±25, 50, 100 Pa)
MS-221	0-10 V	±0.1 in, 0.25 in, 0.5 in w.c. (±25, 50, 100 Pa)
MS-621	0-5 V	±0.1 in, 0.25 in, 0.5 in w.c. (±25, 50, 100 Pa)

*Note: For duct mount static pressure probe, change last digit from 1 to 2. **Example:** MS-122

ACCESSORIES	
Model	Description
A-435	Field upgradeable LCD
A-480	Plastic static pressure tip
A-481	Installer kit. Includes 2 plastic static pressure tips and 7 ft (2.1 m) of PVC tubing
A-489	4" straight static pressure tip with flange
A-302F-A	303 SS Static Pressure Tip with mounting flange. For 3/16" ID rubber or plastic tubing. 4" insertion depth. Includes mounting screws
SCD-PS	100-240 VAC/VDC to 24 VDC Power supply

OPTIONS	
To order add suffix:	Description
-LCD	Units with display
Example: MS-121-LCD	
-NIST	NIST traceable calibration certificate
Example: MS-021-NIST	
-FC	Factory calibration certificate
Example: MS-021-FC	

DIGIHELIC® 3 DIFFERENTIAL PRESSURE CONTROLLERS

Digihelic® Controller in Photohelic® Gage, Square Root Output for Flow



Note: Shown with optional -SS bezel.
Backward compatible* with Magnehelic® gage.

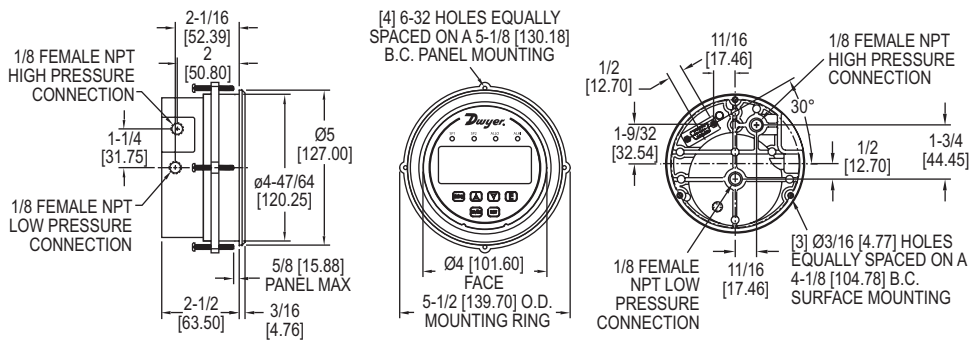

The Series DH3 Digihelic® 3 Differential Pressure Controllers are 3-in-1 instruments possessing a digital display gage, control relay switches, and a transmitter with current output all packed in the popular Photohelic® gage style housing. Combining these 3 features allows the reduction of several instruments with one product, saving inventory, installation time and money. The Digihelic® controller is the ideal instrument for pressure, velocity and flow applications, achieving a 1% full-scale accuracy on ranges down to the extremely low 0.25 in w.c. to 2.5 in w.c. full-scale. Ranges of 5 in w.c. and greater maintain 0.5% FS accuracy. Bi-directional ranges are also available. The Series DH3 Digihelic® controller allows the selection of pressure, velocity or volumetric flow operation in several commonly used engineering units. 2 SPDT control relays with adjustable deadbands are provided along with a scalable 4-20 mA process output.

Programming is easy using the menu key to access 5 simplified menus which provide access to: security level; selection of pressure, velocity or flow operation; selection of engineering units; K-factor for use with flow sensors; rectangular or circular duct for inputting area in flow applications; set point control or set point and alarm operation; alarm operation as a high, low or high/low alarm; automatic or manual alarm reset; alarm delay; view peak and valley process reading; digital damping for smoothing erratic process applications; scaling the 4-20 mA process output to fit your applications range and field calibration.

FEATURES/BENEFITS

- 3-in-1 instrument allows the reduction of several instruments with one product, saving inventory, installation time and money
- Full-scale accuracy of 1% even on extremely low ranges, and 0.5% for ranges above 5 in w.c. provide for greater measurement precision
- Secure menu program provides access to device operation only for the right skill level
- Optional stainless steel bezel is the same installation diameter as Magnehelic® gage and simplifies field upgrade to DH3 pressure controller

APPLICATIONS

- SCFM duct flow
- Filter status
- Duct or building static pressure
- Damper and fan control

MODEL CHART

Model	Ranges	Model	Ranges
DH3-002	0 to 0.25 in w.c.	*DH3-010	0 to 50 in w.c.
DH3-003	0 to 0.5 in w.c.	*DH3-011	0 to 100 in w.c.
DH3-004	0 to 1 in w.c.	*DH3-013	0 to ±0.25 in w.c.
DH3-005	0 to 2.5 in w.c.	*DH3-014	0 to ±0.5 in w.c.
DH3-006	0 to 5 in w.c.	*DH3-015	0 to ±1 in w.c.
DH3-007	0 to 10 in w.c.	*DH3-016	0 to ±2.5 in w.c.
DH3-009	0 to 25 in w.c.	*DH3-017	0 to ±5 in w.c.
		*DH3-018	0 to ±10 in w.c.

*Velocity and volumetric flow not available on bi-directional range units and models DH3-010 and DH3-011.

SPECIFICATIONS

Service: Air and non-combustible, compatible gases.	Output Signal: 4-20 mA DC into 900 Ω max.
Wetted Materials: Consult factory.	Zero & Span Adjustments: Accessible via menus.
Housing Material: Die cast aluminum case and bezel.	Response Time: 250 ms (damping set to 1).
Accuracy: ±1.5% for 0.25 in and ±0.25 in w.c. ranges. Ranges 0.5 in to 5 in w.c. and corresponding bi-directional (except ±2.5 in w.c.) ±1%; All other ranges: ±0.5% @ 77°F (25°C) including hysteresis and repeatability (after 1 hour warm-up).	Display: Backlit 4 digit LCD 0.4" height LED indicators for set point and alarm status.
Stability: < ±1% per year.	Electrical Connections: 15 pin male high density D-sub connection. 18" (46 cm) cable with 10 conductors included.
Pressure Limits: Ranges ≤ 2.5 in w.c.: 25 psi; ±2.5"; 5 in w.c.: 5 psi; 10 in w.c.: 5 psi; 25 in w.c.: 5 psi; 50 in w.c.: 5 psi; 100 in w.c.: 9 psi.	Process Connections: 1/8" female NPT. Side or back connections.
Temperature Limits: 32 to 140°F (0 to 60°C).	Mounting Orientation: Mount unit in vertical plane.
Compensated Temperature Limits: 32 to 140°F (0 to 60°C).	Size: 5" (127 mm) OD x 3-1/8" (79.38 mm); -SS bezel: 4-3/4" (120.7 mm) OD x 2-21/32 (67.5 mm).
Thermal Effects: 0.020%/°F (0.036%/°C) from 77°F (25°C). For 0.25 in and ±0.25 in w.c. ranges: ±0.03%/°F (±0.054%/°C).	Weight: 1.75 lb (794 g).
Power Requirements: 12-28 VDC, 12-28 VAC 50 to 400 Hz.	Agency Approvals: CE.
Power Consumption: 3 VA max.	SWITCH SPECIFICATIONS
	Switch Type: 2 SPDT relays.
	Electrical Rating: 1 A @ 30 VAC/VDC.
	Set Point Adjustment: Adjustable via keypad on face.

ACCESSORIES

Model	Description
A-298	Flat aluminum bracket for flush mounting
A-301	Static pressure tip for 1/4" metal tubing connection
A-302	Static pressure tip for 3/16" and 1/8" I.D. plastic or rubber tubing
A-302F-A	303 SS static pressure tip with mounting flange; for 3/16" I.D. rubber or plastic tubing; 4" insertion depth; includes mounting screws
A-370	Mounting bracket flush mount bracket; bracket is then surface mounted; steel with gray hammertone epoxy finish
A-489	4" straight static pressure tip with flange

OPTIONS

To order add suffix:	Description
-SS	304 brushed stainless steel bezel. *Backward compatible with standard Magnehelic® gage installation diameter
Example:	DH3-004-SS
-NIST	NIST traceable calibration certificate
Example:	DH3-004-NIST
-FC	Factory calibration certificate
Example:	DH3-004-FC

Process Tubing Options: See page 93 (Gage Tubing Accessories)

DIGIMAG® DIGITAL DIFFERENTIAL PRESSURE AND FLOW GAGE

24 Volt or Battery Powered, Fits in Magnehelic® Gage Cut-Out

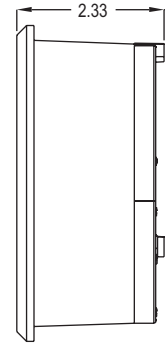
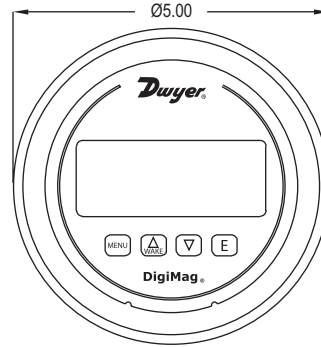

The Series DM-1000 DigiMag® Digital Differential Pressure and Flow Gage monitors the pressure of air and compatible gases just as its famous analog predecessor the Magnehelic® differential pressure gage. All models are factory calibrated to specific ranges. The 4-digit LCD can display readings in common English and metric units so conversions are not necessary. The simplified four button operation reduces set up time and simplifies calibration with its digital push-button zero and span.

FEATURES/BENEFITS

- Field programmed reduces installation time
- User selectable parameters for pressure, air velocity or flow permits same device for multiple applications
- Specialized filter set point for alerts when maintenance is due
- Security levels permit matches the correct access to right skill
- Power versatility works with 9-24 VDC or 9 V battery allows deployment in a variety of spaces wired or not

APPLICATIONS

- Filter monitoring
- Air velocity or flow
- Blower vacuum monitoring
- Fan pressure indication
- Duct, room or building pressures
- Clean room positive pressure indication

ACCESSORIES

Model	Description
A-300	Flat flush mounting bracket
A-286	4-1/2" gage panel mounting flange
A-489	4" straight static pressure tip with flange
A-480	Plastic static pressure tip

SPECIFICATIONS

Service: Air and non-combustible, compatible gases.
Wetted Materials: Consult factory.
Housing Materials: Glass filled plastic.
Accuracy: ±1% FS including linearity, hysteresis and repeatability; ±2% FS for ranges 1 in w.c. and below.
Temperature Limits: 0 to 140°F (-18 to 60°C).
Compensated Temperature Limits: 32 to 122°F (0 to 50°C).
Long Term Stability: ±1% FS per year.
Thermal Effect: ±0.05% FS/°F typ.; ±0.10% FS/°F for ranges 1 in w.c. and below.
Display: 4-digit LCD (digits: 0.60H x 0.33W).
Display Update: Selectable for 1 second to 10 minutes or update only from button push.
Pressure Limits: Normal and bi-directional ranges 5 in w.c. and lower = 2 psi (13.7 kPa); Normal and bi-directional ranges 10 in w.c. and higher = 11 psi (75 kPa).
Selectable Engineering Units: in w.c., psi, kPa, Pa, mm w.c., mBar, in Hg, mm Hg, FS (0-100%).
Power Requirements: 9 V alkaline battery, included, user replaceable or external power supply 9-24 VDC.
Battery Service Life: Battery life depending on the display update setting: 150 hours (typical) if display update = 1 second; 9 month (typical) if display update = 10 minutes; 1.5 years (typical) if display update is disabled. Battery may last up to four times longer when using lithium-based battery ULTRALIFE U9VL-J.
Current Consumption: 5 mA max.
Electrical Connections: Removable terminal block for 16 to 26 AWG.
Electrical Entry: Cable gland for 0.114 to 0.250" (2.9 to 6.4 mm) diameter cable.
Process Connections: 1/8" (3 mm) ID tubing.
Enclosure Rating: NEMA 4X (IP66).
Weight: 1.18 lb (535 g).
Size: 5" (127 mm) OD front face.
Agency Approvals: CE.

MODEL CHART

Model	Range									Resolution in w.c.
	in w.c.	psi	kPa	Pa	mbar	mm w.c.	in Hg	mm Hg	% of FS	
DM-1102	0.250	—	0.062	62.20	0.622	6.35	—	0.467	100.0	0.001
DM-1103	0.500	—	0.124	124.5	1.245	12.70	—	0.934	100.0	0.001
DM-1104	1.000	—	0.249	249.1	2.492	25.40	—	1.868	100.0	0.001
DM-1105	2.000	—	0.498	498.2	4.982	50.80	—	3.736	100.0	0.001
DM-1107	5.000	0.181	1.245	1245	12.45	127.0	0.368	9.34	100.0	0.002
DM-1108	10.00	0.361	2.491	2491	24.91	254.0	0.736	18.68	100.0	0.010
DM-1109	15.00	0.543	3.738	3738	37.38	381.0	1.104	28.02	100.0	0.010
DM-1110	25.00	0.903	6.227	6227	62.27	635.0	1.839	46.71	100.0	0.010
DM-1111	50.00	1.806	12.45	—	—	1270	3.678	93.42	100.0	0.020
DM-1112	100.0	3.613	24.91	—	—	2540	7.355	186.8	100.0	0.100

Contact the factory for available bi-directional ranges from ±0.25 to ±10 in w.c.

Note: For air flow models change -11XX to -12XX.

OPTIONS

To order add suffix:	Description
-NIST	NIST traceable calibration certificate
Example: DM-1103-NIST	

DIFFERENTIAL PRESSURE TRANSMITTERS

Same Size as Standard Magnehelic® Differential Pressure Gage



DM-2000-LCD



DM-2100-LCD

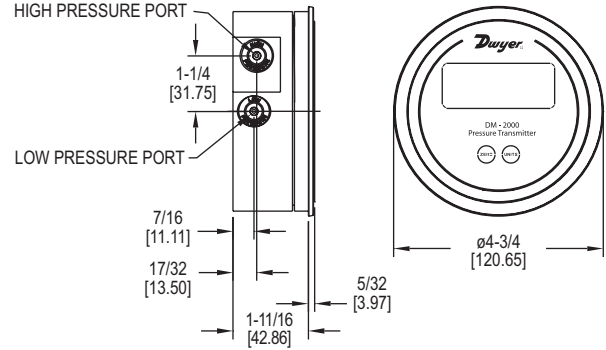

The Dwyer **Series DM-2000 Differential Pressure Transmitters** sense the pressure of air and compatible gases and sends a standard 4-20 mA output signal. The DM-2000 housing is specifically designed to mount in the same diameter cutout as a standard Magnehelic® gage. A wide range of models are available factory calibrated to specific ranges.

Pressure connections are inherent to the glass filled plastic molded housing making installation quick and easy. Digital push-button zero and span simplify calibration over typical turn-potentiometers. An optional 3.5 digit LCD shows process and engineering units. A single push-button allows field selection of 4 to 6 engineering units depending on range.

FEATURES/BENEFITS

- Zero and span controls provide easy calibration checks and shorter installation time to get device running and monitoring
- Quick response to pressure changes means no delay in signaling and alerting to critical situations
- Easy to read LCD display provides immediate local alerts allowing corrective action to be taken quicker to eliminate the problem from becoming widespread
- Same size as Magnehelic® simplifies field upgrade to digital pressure gage by reducing install steps
- Tamper proof button configuration to prevent accidental changes to the settings

APPLICATIONS

- Differential pressure across filters
- Fan control
- Static pressures in ducts or buildings

MODEL CHART						
Model	Range (in w.c.)	Pa	mm w.c.	mBar	kPa	psi
DM-2001-LCD	0 to .100	24.9	2.54	.249	-	-
DM-2002-LCD	0 to .250	62.2	6.35	.622	-	-
DM-2003-LCD	0 to .500	124.3	12.70	1.243	.124	-
DM-2004-LCD	0 to 1.000	249	25.4	2.49	.249	-
DM-2005-LCD	0 to 2.00	497	50.8	4.97	.497	-
DM-2006-LCD	0 to 3.00	746	76.2	7.46	.746	.108
DM-2007-LCD	0 to 5.00	1243	127.0	12.43	1.243	.180
DM-2012-LCD	0 to ±.250	0 to ±62.2	0 to ±6.35	0 to ±.622	-	-
DM-2013-LCD	0 to ±.500	0 to ±124.3	0 to ±12.70	0 to ±1.243	-	-
DM-2019-LCD	0 to ±.200	0 to ±49.8	0 to ±5.08	0 to ±.498	-	-

Note: For white overlay change -20 to -21. **Example:** DM-2102-LCD

SPECIFICATIONS

- Service:** Air and non-combustible, compatible gases.
- Wetted Materials:** Consult factory.
- Accuracy:** ±1% FS at 70°F.
- Stability:** ±1% FS/yr.
- Temperature Limits:** 20 to 120°F (-6.67 to 48.9°C).
- Pressure Limits:** 10 psig (0.69 bar).
- Thermal Effect:** ±0.055% FS/°F (0.099% FS/°C).
- Power Requirements:** 10-35 VDC (2 wire).
- Output Signal:** 4-20 mA.
- Zero and Span Adjustments:** Digital push-button zero and span.
- Loop Resistance:** DC: 0 to 1250 Ω maximum.
- Current Consumption:** DC: 38 mA max.
- Electrical Connections:** Screw-type terminal block.
- Display:** 3.5 digit LCD, 0.7" H.
- Process Connections:** 1/8" ID tubing.
- Mounting Orientation:** Vertical.
- Weight:** 4.8 oz (136 g).

ACCESSORIES	
Model	Description
A-299	Surface mounting bracket
A-300	Flat flush mounting bracket
A-302F-A	303 SS static pressure tip with mounting flange; for 3/16" ID rubber or plastic tubing; 4" insertion depth; includes mounting screws
A-320-A	Instrument enclosure
A-489	4" straight static pressure tip with flange
SCD-PS	100-240 VAC/VDC to 24 VDC power supply

OPTIONS	
To order add suffix:	Description
-NIST	NIST traceable calibration certificate
Example: DM-2002-LCD-NIST	
-FC	Factory calibration certificate
Example: DM-2002-LCD-FC	

DIFFERENTIAL PRESSURE TRANSMITTER

NEMA 4X Enclosure, 0.25% FS Accuracy

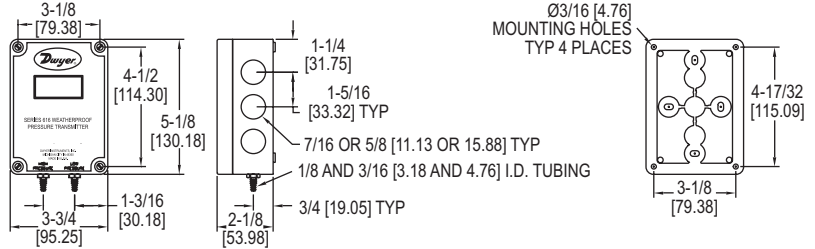

Positive, negative and differential pressures can be measured within a full span accuracy of ± 0.25 with the **Series 616W Differential Pressure Transmitter**. Units are enclosed in a polycarbonate case, rated NEMA 4X (IP66) and operate by sensing the pressure of air and compatible gases then sending a standard 4-20 mA output signal. Design enables operation in 2-wire current loops. A wide range of models are available factory calibrated to specific ranges. The span and zero controls are for use when checking calibration. They are not intended for re-ranging to a significantly different span. The LCD display allows local indication of pressure.

FEATURES/BENEFITS

- NEMA 4X rated enclosure provides protection in harsh environments permitting outdoor monitoring or in areas where dust and particulate matter exists
- Easy to read LCD display provides immediate local alerts allowing corrective action to be taken quicker to eliminate the problem from becoming widespread
- Zero and span controls provides easy calibration checks and shorter installation time to get device running and monitoring

APPLICATIONS

- Dust collection
- Outdoor HVAC
- Roof-top equipment

MODEL CHART

Model	Range	Max. Pressure
616W-2-LCD	0 to 6 in w.c.	10 psig
616W-3-LCD	0 to 10 in w.c.	10 psig
616W-4-LCD	0 to 20 in w.c.	20 psig
616W-5-LCD	0 to 40 in w.c.	20 psig
616W-6-LCD	0 to 100 in w.c.	15 psig
616W-7-LCD	0 to 200 in w.c.	45 psig
616W-20B-LCD	0 to ± 10 in w.c.	10 psig
616W-3M-LCD	0 to 2.5 kPa	68.9 kPa

Note: Units with "M" in the model number are metric units.

SPECIFICATIONS

Service: Air and non-combustible, compatible gases.
Wetted Materials: Consult factory.
Accuracy: $\pm 0.25\%$ FS @ 77°F (25°C), display accuracy $\pm 0.5\%$.
Stability: $\pm 1\%$ FS/yr.
Temperature Limits: 14 to 185°F (-10 to 85°C).
Pressure Limits: See chart.
Power Requirements: 10-35 VDC (2-wire), 17-36 VDC, or isolated 21.6-33 VAC (3-wire).
Output Signal: 4-20 mA (2-wire), 0-5 VDC, or 0-10 VDC (3-wire).
Zero and Span Adjustments: Push-buttons.

Loop Resistance: Current output: 0 to 1250 Ω max; Voltage output: Load resistance 1 k Ω (min).
Current Consumption: 40 mA (max).
Electrical Connections: 3-wire removable European style terminal block for 16 to 26 AWG.
Process Connections: Barbed, dual size to fit 1/8" and 3/16" (3.12 and 4.76 mm) ID rubber or vinyl tubing.
Enclosure Rating: NEMA 4X (IP66).
Mounting Orientation: Any orientation.
Weight: Without LCD 8.8 oz. (249 g); with LCD 9.6 oz (272 g).
Agency Approvals: CE.

OPTIONS

To order add suffix:	Description
-NIST	NIST traceable calibration certificate
Example: 616W-3-LCD-NIST	

Process Tubing Options: See page 93 (Gage Tubing Accessories)

SERIES 616WL

DIFFERENTIAL PRESSURE TRANSMITTER

Low Ranges Down to 0.25 in w.c. (60 Pa), NEMA 4X Housing (IP66)

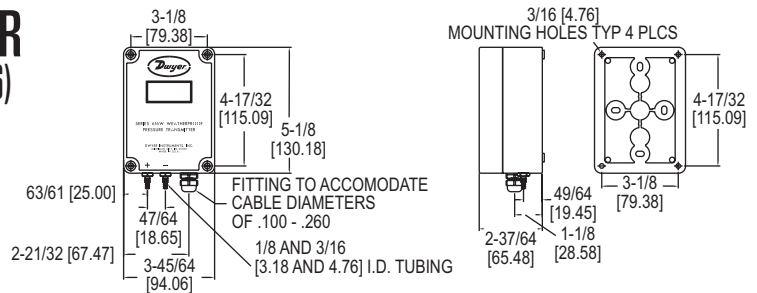

The **Series 616WL Differential Pressure Transmitter** senses very low pressures of air and non-combustible, compatible gases and sends a standard 4-20 mA output signal. All models, including those featuring the 3 digit LCD digital read-out, are factory calibrated to specific ranges as listed in the chart below. Positive, negative and differential pressures can be measured within a full span accuracy of $\pm 0.50\%$. This weatherproof unit is enclosed in a polycarbonate case, designed to meet (IP66/ NEMA 4X). Internal digital push-button zero and span allow for quick and simple field calibration.

FEATURES/BENEFITS

- NEMA 4X rated enclosure provides protection in harsh environments permitting outdoor monitoring or in areas where dust and particulate matter exists
- Easy to read LCD display provides immediate local alerts allowing corrective action to be taken quicker to eliminate the problem from becoming widespread
- Zero and span controls provides easy calibration checks and shorter installation time to get device running and monitoring
- High precision accuracy at low pressure ranges provides exceptional accuracy for insuring tight-control and minimizing costly out of specification conditions

APPLICATIONS

- Low pressure applications
- Outdoor HVAC
- Dust collection
- Roof-top equipment

OPTIONS

To order add suffix:	Description
-NIST	NIST traceable calibration certificate
Example: 616WL-4-LCD-NIST	

SPECIFICATIONS

Service: Air and non-combustible, compatible gases.
Wetted Materials: Consult factory.
Accuracy: $\pm 0.50\%$ FS, display accuracy $\pm 0.5\%$.
Stability: $\pm 1\%$ FS/yr.
Temperature Limits: 0 to 140°F (-17.8 to 60°C).
Compensated Temperature Limits: 20 to 120°F (-6.67 to 48.9°C).
Pressure Limits: See chart.
Thermal Effect: $\pm 0.02\%$ FS/°F (0.036% FS/°C).
Power Requirements: 12-30 VDC (2-wire).
Output Signal: 4-20 mA.

Zero and Span Adjustments: Digital, push-button adj.
Loop Resistance: DC; 0 to 900 Ω max.
Current Consumption: DC; 38 mA max.
Electrical Connections: Screw-type terminal block.
Process Connections: Barbed, dual size to fit 1/8" and 3/16" (3.12 and 4.76 mm) ID rubber or vinyl tubing.
Enclosure Rating: NEMA 4X (IP66).
Mounting Orientation: Vertical, consult factory for other position orientations.
Weight: Without LCD 17 oz (482 g); with LCD 18 oz (510 g).
Agency Approvals: CE.

MODEL CHART

Model	Range	Max. Pressure
616WL-2-LCD	0 to 0.25 in w.c.	2 psig
616WL-4-LCD	0 to 1 in w.c.	4 psig
616WL-12-LCD	0 to ± 0.25 in w.c.	2 psig
616WL-14-LCD	0 to ± 1 in w.c.	4 psig
616WL-22-LCD	0 to 60 Pa	2 psig
616WL-32-LCD	0 to ± 60 Pa	2 psig
616WL-25-LCD	0 to 250 Pa	4 psig
616WL-35-LCD	0 to ± 250 Pa	4 psig

Process Tubing Options: See page 93 (Gage Tubing Accessories)

MAGNEHELIC® DIFFERENTIAL PRESSURE GAGES

Indicate Positive, Negative or Differential, Accurate within 1%



Standard Magnehelic® gage



High Accuracy Magnehelic® gage
Note: Shown with optional -SS bezel

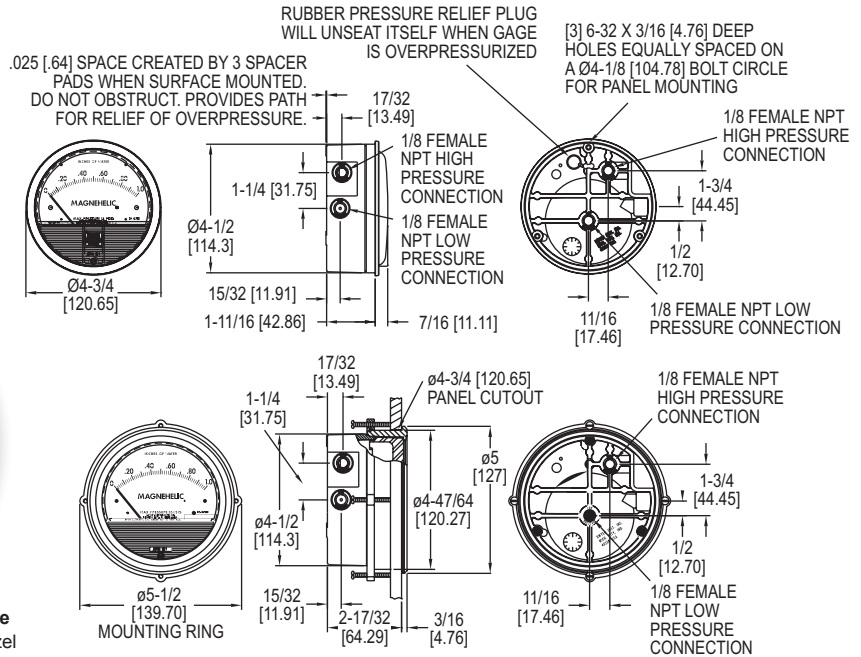

Select the **Series 2000 Magnehelic® Differential Pressure Gages** for a versatile low differential pressure gage with a wide choice of 81 models and 27 options to choose from. Using Dwyer's simple, frictionless Magnehelic® gage movement, it quickly indicates air or non-corrosive gas pressures--either positive, negative (vacuum) or differential. The design resists shock, vibration, over-pressures and is weatherproof to IP67.

Select the -HA High Accuracy Magnehelic® gage option for an accuracy within 1% of full-scale. Also included with the -HA option at no extra cost are a mirrored scale overlay and a 6 point calibration certificate.

FEATURES/BENEFITS

- Easy to read gage through undistorted plastic face permits viewing from far away
- Patented design provides quick response to pressure changes means no delay in assessing critical situations
- Durable and rugged housing and high-quality components combine to provide long-service life and minimized down-time
- High accuracy option is twice as accurate as the standard Magnehelic® gage

APPLICATIONS

- Filter monitoring
- Air velocity with Dwyer pitot tube
- Blower vacuum monitoring
- Fan pressure indication
- Duct, room or building pressures
- Clean room positive pressure indication

ACCESSORIES

Model	Description
A-432	Portable kit; combine carrying case with any Magnehelic® gage of standard range, except high pressure connection. Includes 9 ft (2.7 m) of 3/16" ID rubber tubing, standhang bracket and terminal tube with holder
A-605	Air filter gage accessory kit; adapts any standard Magnehelic® gage for use as an air filter gage. Includes aluminum surface mounting bracket with screws, two 5 ft (1.5 m) lengths of 1/4" aluminum tubing, two static pressure tips and two molded plastic vent valves, integral compression fittings on both tips and valves
A-605B	Air filter gage accessory kit; air filter kit with two plastic open/close valves, two 4" steel static tips, plastic tubing and mounting flange
A-605C	Air filter gage accessory kit; air filter kit with two plastic open/close valves, two plastic static tips, plastic tubing and mounting flange

SPECIFICATIONS

Service: Air and non-combustible, compatible gases (natural gas option available).
Note: May be used with hydrogen. Order a Buna-N diaphragm. Pressures must be less than 35 psi.
Wetted Materials: Consult factory.
Housing: Die cast aluminum case and bezel, with acrylic cover. Exterior finish is coated gray to withstand 168 hour salt spray corrosion test.
Accuracy: ±2% (-HA model ±1) of FS (±3% (-HA ±1.5%) on -0, -100PA, -125PA, -10MM and ±4% (-HA ±2%) on -00, -60PA, -6MM ranges), throughout range at 70°F (21.1°C).
Pressure Limits: -20 in Hg to 15 psig (-0.677 to 1.034 bar); MP option: 35 psig (2.41 bar); HP option: 80 psig (5.52 bar).
Enclosure Rating: IP67.
Overpressure: Relief plug opens at approximately 25 psig (1.72 bar), standard gages only. **Ⓢ**
Temperature Limits: 20 to 140°F* (-6.67 to 60°C). -20°F (-28°C) with low temperature option.
Size: 4" (101.6 mm) diameter dial face.
Mounting Orientation: Diaphragm in vertical position. Consult factory for other position orientations.
Process Connections: 1/8" female NPT duplicate high and low pressure taps - one pair side and one pair back.
Weight: 1 lb 2 oz (510 g), MP & HP 2 lb 2 oz (963 g).
Standard Accessories: Two 1/8" NPT plugs for duplicate pressure taps, two 1/8" pipe thread to rubber tubing adapter, and three flush mounting adapters with screws. (Mounting and snap ring retainer substituted for three adapters in MP & HP gage accessories.)
Agency Approvals: Meets the technical requirements of EU Directive 2011/65/EU (RoHS II). **Note:** -SP models not RoHS approved.
Note: For applications with high cycle rate within gage total pressure rating, next higher rating is recommended. See Medium and High pressure options.
 *Low temperature models available as special options.



A-432

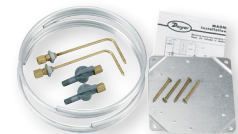

A-605

Ⓢ Over Protection Note: See page 8 (Series 2000)



HIGH ACCURACY MAGNEHELIC® DIFFERENTIAL PRESSURE GAGE

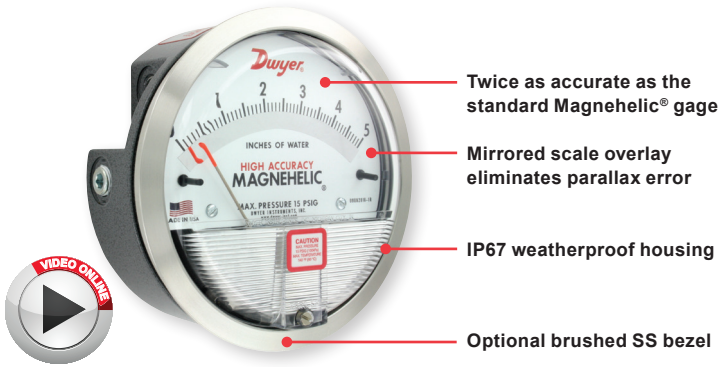

6-point calibration certificate included

OPTIONS - HIGH ACCURACY MAGNEHELIC® GAGE	
To order add suffix:	Description
-HA	High accuracy Magnehelic® gage. Accuracy within 1% and weatherproof. Also includes mirrored scale overlay and a six point calibration certificate
-SS	Corrosion resistant brushed 304 stainless steel bezel

Accuracy Specifications: See page 7 (Series 2000)

ADDITIONAL GAGE OPTIONS

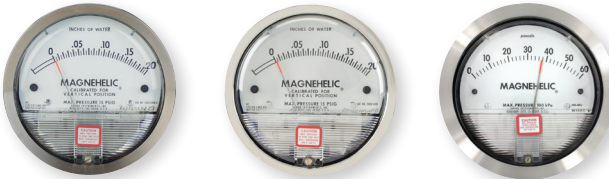

OPTIONS - OTHER OPTIONAL BEZELS	
To order add suffix:	Description
-CB	Chrome bezel option: A chrome plated aluminum bezel for an aesthetically pleasing finish when mounting on metal surfaces such as control panels.
-SB	Stainless steel bezel option: 304 stainless steel electro polished Ra 16 finished bezel.
-SS	Corrosion resistant brushed 304 stainless steel bezel



LED set point indicator

Adjustable signal flag

OPTIONS - LED SET POINT INDICATOR	
To order add suffix:	Description
-SP	Bright red LED on right scale shows when set point is reached. Field adjustable from gage face, unit operates on 12-24 VDC. Set point indicator option comes with medium pressure (MP) bezel.

Note: 4-13/16" hole for flush mounting.



Transparent overlay

Mirrored scale overlay

OPTIONS - ADJUSTABLE SIGNAL FLAG	
To order add suffix:	Description
-ASF	Integral with plastic gage cover. Available for most models except those with medium or high pressure construction. Can be ordered with gage or separate.

OPTIONS - TRANSPARENT OVERLAYS	
To order add suffix:	Description
-G	Green (to highlight and emphasize critical pressures)
-R	Red (to highlight and emphasize critical pressures)
-Y	Yellow (to highlight and emphasize critical pressures)



Integrated mounting plate

OPTIONS - MIRRORED SCALE OVERLAY	
To order add suffix:	Description
-M	A mirrored scale overlay is also available to assist in reducing parallax error.

OPTIONS - INTEGRATED MOUNTING PLATE	
To order add suffix:	Description
-AHU1	Furnished with attached surface mounting plate
-AHU2	Furnished with attached surface mounting plate and including A-481 installer kit (2 plastic static pressure tips and 7' of PVC tubing)



OPTIONS - FOR HIGH STATE PRESSURE APPLICATIONS	
To order add suffix:	Description
-HP	High pressure option: for pressures to 80 psig
-MP	Medium pressure option: for pressures to 35 psig

OPTIONS	
To order add suffix:	Description
-FC	Factory calibration certificate
-LT	Low temperatures to -20°F (-28°C)
-NIST	NIST traceable calibration certificate

MAGNEHELIC® GAGE MOUNTING ACCESSORIES



A-610



A-369



Pressure reference port



A-464

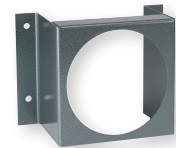

A-299



A-286



A-300



A-368

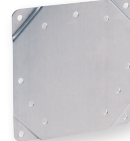

A-371

A single case size is used for most models of Magnehelic® gages. They can be flush or surface mounted with standard hardware supplied. Complete mounting and connection fittings plus instructions are furnished with each instrument. A 4-9/16" hole is required for flush panel mounting.

Flush mounting is easily accomplished with the new A-300 Flush Mounting bracket. This bracket provides a solution to quickly and conveniently flush mount the Magnehelic® gage. The A-300 is ideal for mounting the Magnehelic® gage on control panel doors.

The A-368 is a simple bracket for quickly surface mounting the Magnehelic® gage. After securing the Magnehelic® gage to the A-368 bracket, mount the bracket on any flat surface.

The A-369 allows the Magnehelic® gage to be easily carried to locations where pressure readings need to be taken. The A-369 can stand on its own or hang on a nail or hook.

ACCESSORIES	
Model	Description
A-610	Pipe mounting kit for installing on 1-1/4" to 2" horizontal or vertical pipe
A-286	Magnehelic® gage panel mounting flange
A-369	Stand-hang bracket, aluminum, for Magnehelic® gage
A-300	Flush mounting bracket
A-464	Flush mount kit for Magnehelic® gage
A-368	Surface mounting plate, aluminum, for Magnehelic® gage
A-299	Mounting bracket, flush mount for Magnehelic® gage, bracket is then surface mounted, steel with gray hammerloid epoxy finish
A-371	Surface mounting bracket, use with medium pressure (-MP) or high pressure (-HP) models only

SERIES A-320

INSTRUMENT ENCLOSURES

Protects Various Instruments



A-320-A1



A-320-B1



A-320-BC



A-320-A-SS



A-320-B-SS

The Series A-320 Instrument Enclosures protect instruments in all applications. The enclosures, available in plastic and stainless steel, fit a variety of gages including the Series 605 transmitter, DM-2000, 3000MR/MRS and DH3. All models include silicone tubing, Banjo fittings, and threaded pressure connections pre-installed. The threaded pressure connections allow the user to easily change the connection type through the use of fittings or adapters. This modification can be implemented to allow connection to a wide variety of plastic or metal tubing.

SPECIFICATIONS	
Housing Material:	ABS plastic or 304 SS.
Process Connection:	1/8" female NPT (-SS models: 1/8" BSPT).
Enclosure Rating:	Plastic models: IP66.
Weight:	A-320-A1: 1.1 lb (0.5 kg); A-320-B1: 1.4 lb (0.65 kg); A-320-BC: 1.4 lb (0.65 kg); A-320-A-SS: 2.3 lb (1.05kg); A-320-B-SS: 3.0 lb (1.35 kg).

MODEL CHART	
Model	Description
A-320-A1*	2000 Magnehelic® gage, DM-2000 differential pressure transmitter
A-320-B1**	3000MR/MRS Photohelic® switch/gage, Series 605 Magnehelic® differential pressure transmitter, DH3 DigiHelic® pressure controller, 2000 Magnehelic® gage with medium and high pressure options
A-320-BC	2000 Magnehelic® gage, DM-1000 DigiMag® digital differential pressure gage, DM-2000 differential pressure transmitter, instruments with backwards compatible bezel option
A-320-A-SS	2000 Magnehelic® gage
A-320-B-SS	2000 Magnehelic® gage, DM-2000 differential pressure transmitter

*DM-2000 must be mounted horizontally in A-320-A1 enclosure.
 **For DH3 to fit on A-320-B1 the casing on the electrical plug must be removed.

ACCESSORIES	
Model	Description
A-339-SS	1/8" male BSPT to 3/16" hose barb

MAGNEHELIC® DIFFERENTIAL PRESSURE INDICATING TRANSMITTER

Same Size as Standard Magnehelic® Differential Pressure Gage



Note: Shown with optional -SS bezel.
Backward compatible* with Magnehelic® gage.

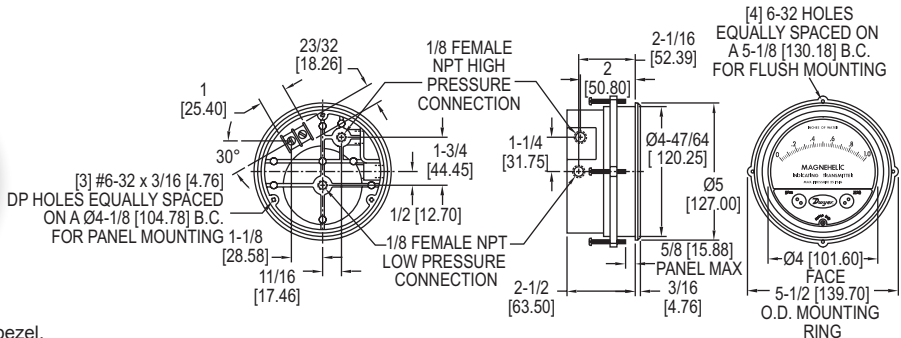

The Series 605 Magnehelic® Differential Pressure Indicating Transmitter provides for both visual monitoring and electronic control of very low differential pressure. The Series 605 is ideal for control applications in building HVAC systems where local indication is desired during routine maintenance checks or necessary when trouble shooting the system. The easily read dial gage is complimented by the two-wire, 4-20 mA control signal utilizing the time-proven Dwyer® Magnehelic® gage mechanical design and Series 600 transmitter technology. The two-wire design with terminal strip on the rear simplifies connection in any 4-20 mA control loop powered by a 10-35 VDC supply.

FEATURES/BENEFITS

- Easy to read gage permits viewing from far away
- Patented design provides quick response to pressure changes means no delay in signaling and alerting to critical situations
- Durable and rugged housing and high-quality components combined provides long-service life and minimized down-time
- Optional stainless steel bezel is the same installation diameter as Magnehelic® gage and simplifies field upgrade to 605 indicating transmitter

APPLICATIONS

- Monitor pressures in ducts, rooms, or total building pressures
- Filter monitoring
- Local indication of clean room pressures with process signal sent to control room

MODEL CHART				
Model	Range in w.c.	Maximum Pressure	Electrical Accuracy ±%	Mechanical Accuracy ±%
605-00N	0.05-0-0.2	10 psi (68.95 kPa)	4	4
605-11	0 to ±.25	10 psi (68.95 kPa)	2	3
605-0	0 to .50	10 psi (68.95 kPa)	2	3
605-1	0 to 1.0	10 psi (68.95 kPa)	2	2
605-2	0 to 2.0	2 psi (13.79 kPa)	0.5	2
605-3	0 to 3.0	2 psi (13.79 kPa)	0.5	2
605-6	0 to 6.0	2 psi (13.79 kPa)	0.5	2
605-10	0 to 10	2 psi (13.79 kPa)	0.5	2
605-20	0 to 20.0	11 psi (75.8 kPa)	0.5	2
605-30	0 to 30	11 psi (75.8 kPa)	0.5	2
605-50	0 to 50	11 psi (75.8 kPa)	0.5	2
Model	Range in Pa	Maximum Pressure	Electrical Accuracy ±%	Mechanical Accuracy ±%
605-12	0 to ±60	10 psi (68.95 kPa)	4	4
605-13	0 to ±100	10 psi (68.95 kPa)	2	2
605-60PA	0 to 60	10 psi (68.95 kPa)	2	4
605-125PA	0 to 125	10 psi (68.95 kPa)	2	3
605-250PA	0 to 250	10 psi (68.95 kPa)	2	2
605-500PA	0 to 500	2 psi (13.79 kPa)	0.5	2

OPTIONS	
To order add suffix:	Description
-SS	304 brushed stainless steel bezel. *Backward compatible with standard Magnehelic® gage installation diameter
Example: 605-3-SS	
-NIST	NIST traceable calibration certificate
Example: 605-3-NIST	

SPECIFICATIONS

GAGE SPECIFICATIONS

- Service:** Air and non-combustible, compatible gases.
- Wetted Materials:** Consult factory.
- Accuracy:** See chart.
- Stability:** ±1% FS/yr.
- Pressure Limits:** See chart.
- Temperature Limits:** 20 to 120°F (-6.67 to 48.9°C).
- Process Connections:** 1/8" female NPT.
- Size:** 4" (101.6 mm) dial face, 5" (127 mm) OD x 2-11/16" (68.3 mm); -SS bezel: 4-3/4" (120.7 mm) OD x 2-21/32 (67.5 mm).
- Weight:** 1 lb 12.6 oz (811 g).
- Agency Approvals:** CE.

TRANSMITTER SPECIFICATIONS

- Accuracy:** See chart (includes linearity, hysteresis, repeatability).
- Temperature Limits:** 20 to 120°F (-6.67 to 48.9°C).
- Compensated Temperature Range:** 32 to 120°F (0 to 48.9°C).
- Thermal Effect:** ±0.025% FS/°F (0.045% FS/°C).
- Power Requirements:** 10-35 VDC (2-wire).
- Output Signal:** 4-20 mA.
- Zero and Span Adjustments:** Protected potentiometers.
- Loop Resistance:** DC: 0 to 1250 Ω max.
- Current Consumption:** DC: 38 mA max.
- Electrical Connections:** Screw terminal block.
- Mounting Orientation:** Diaphragm in vertical position. Consult factory for other position orientations.

ACCESSORIES	
Model	Description
A-298	Flat aluminum bracket for flush mounting
A-370	Mounting bracket; flush mount Series 605 transmitter in bracket; bracket is then surface mounted; steel with gray hammertone epoxy finish

Static Fitting Options: See page 92 (Static Pressure Tips)
Process Tubing Options: See page 93 (Gage Tubing Accessories)

CAPSUHELIC® DIFFERENTIAL PRESSURE GAGE

Measures Pressure, Vacuum or Differential, Suitable for Internal Pressures to 500 psig



Capsuhelic® pressure gage has a large, easy-to-read 4" (102 mm) dial.

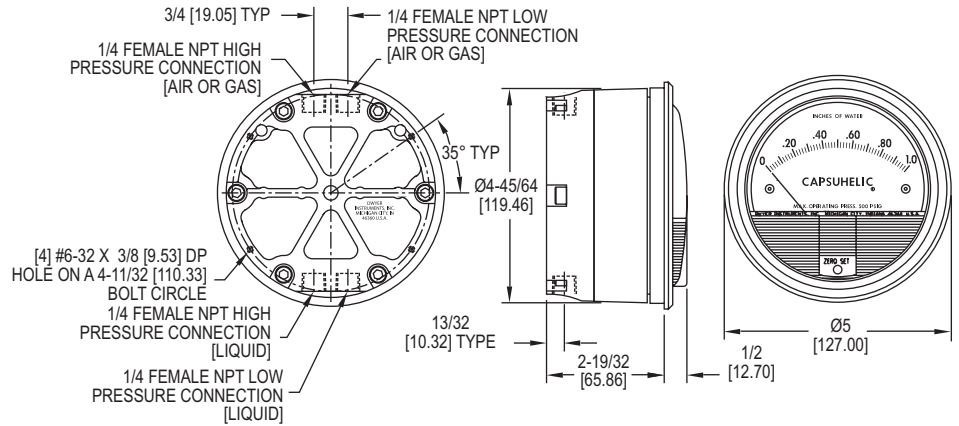

The Series 4000 Capsuhelic® Differential Pressure Gage is designed to give fast, accurate indication of differential pressures. The gage may be used as a readout device when measuring flowing fluids, pressure drop across filters, liquid levels in storage tanks and many other applications involving pressure, vacuum or differential pressure.

The pressure being measured is held within a capsule which is an integral part of the gage. This containment of the pressure permits the use of the gage on system pressures of up to 500 psig, even when differentials to be read are less than 0.1 in w.c.

FEATURES/BENEFITS

- Gage capsule permits high-pressure usage with small differentials
- Zero and range adjustments outside of gage means no disassembly in normal service
- Time-proven, simple, frictionless movement that permits full-scale readings as low as 0.5 in w.c.
- Diaphragm-actuated versus liquid filled gage supports outdoor use

APPLICATIONS

- Fluid flow
- Liquid storage tanks
- Filter pressure drops
- Vacuum or differential pressure

Note: May be used with hydrogen where pressures are less than 35 psi. Order with a Buna-N diaphragm.

MODEL CHART			
Model	Range	Model	Range
4005*	0-5.0 in w.c.	4310	5-0-5 in w.c.
4006*	0-6.0 in w.c.	4330	15-0-15 in w.c.
4010*	0-10 in w.c.	4205	0-5 psid
4015*	0-15 in w.c.	4210	0-10 psid
4020*	0-20 in w.c.	4215	0-15 psid
4025*	0-25 in w.c.	4220	0-20 psid
4030*	0-30 in w.c.	4616B**	0-16 ft w.c.
4040*	0-40 in w.c.	4635	0-35 ft w.c.
4050*	0-50 in w.c.		
4060*	0-60 in w.c.		
4080*	0-80 in w.c.		
4100*	0-100 in w.c.		
4200*	0-200 in w.c.		

*These ranges available for vertical scale position only.
 **Available only with the brass case for water service.
Note: Scales reading directly in flow, heights, etc., are also available.

SPECIFICATIONS

Service: Aluminum case: Air and compatible gases and oil based liquids; Brass case: Air and compatible gases and water based liquids.
Wetted Materials: Consult factory.
Housing: Die cast aluminum with impregnated hard coating, standard. Optional forged brass housing is required for water or water based fluids. Special material diaphragms available, contact factory.
Accuracy: ±3% of FS at 70°F (21.1°C). (±4% on 4200, 4210, 4215, 4220, 4300, 4400, and 4500).
Pressure Limits: -20" Hg to 500 psig (-0.677 bar to 34.4 bar).
Temperature Limits: 20 to 200°F (-6.67 to 93.3°C).
Size: 4" (101.6 mm) diameter dial face.
Mounting Orientation: Diaphragm in vertical position. Consult factory for other position orientations.
Process Connections: 1/4" female NPT high and low pressure taps, duplicated - one pair top for air and gas, and one pair bottom for liquids.
Weight: 3 lb, 3 oz (1.45 kg) aluminum case; 7 lb, 13 oz (3.54 kg) brass case.

OPTIONS

To order add suffix:	Description
-ASF	Adjustable signal flag
B	Brass case
Scale Overlays	Red, green, mirrored or combination; specify locations
-NIST	NIST traceable calibration certificate

ACCESSORIES - STANDARD

Description
 Two 1/4" NPT plugs for duplicate pressure taps, four flush mounting adapters with screws and four surface mounting screws.

ACCESSORIES

Model	Description
A-298	Flat flush mounting bracket
A-309	3-way manifold valve
A-314	Bleed fitting
A-370	Mounting bracket
A-471	Portable kit
A-496	Flush mount bracket
A-610	Pipe mount kit

USA: California Proposition 65
 ⚠WARNING: Cancer and Reproductive Harm - www.P65Warnings.ca.gov

Process Tubing Options: See page 93 (Gage Tubing Accessories)

PHOTOHELIC® SWITCH/GAGES

Combines Differential Pressure Gage with Low/High Set-Points, Compact Size



Note: Shown with optional -SS bezel.
Backward compatible* with Magnehelic® gage.

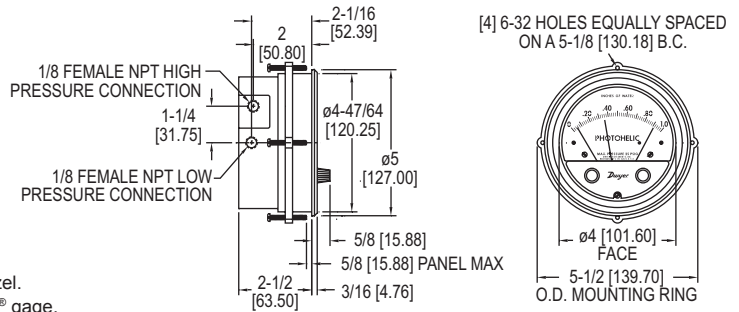

Using solid state technology, the **Series 3000MR & 3000MRS Photohelic® Switch/Gages** combine the functions of a precise, highly repeatable differential pressure switch with a large easy-to-read analog pressure gage employing the durable, time-proven Magnehelic® gage design. Switch setting is easy to adjust with large external knobs on the gage face. Gage reading is unaffected by switch operation - will indicate accurately even if power is interrupted. Solid state design now results in greatly reduced size and weight. Units can be flush mounted or surface mounted with hardware supplied. 3000MR models employ versatile electromechanical relays with gold over silver contacts - ideal for dry circuits. For applications requiring high cycle rates, choose 3000MRS models with SPST (N.O.) solid state relays. All models provide both low and high limit control and include 18-inch (45 cm) cable assemblies for electrical connections. Compatible with air and other non-combustible, non-corrosive gases, they can be used in systems with pressures to 25 psig (1.725 bar). Optional construction is available for use to either 35 psig (2.42 bar) or 80 psig (5.51 bar).

FEATURES/BENEFITS

- Gage reading unaffected by switch operation and will continue to read pressure even during power loss
- Zero and range adjustments outside of gage means no disassembly in normal service
- Solid-state design allows for switching in high cycle rate applications without degradation
- Optional stainless steel bezel is the same installation diameter as Magnehelic® gage and simplifies field upgrade to Photohelic® switch/gage

APPLICATIONS

- Pneumatic conveying
- Air conditioning systems
- Clean rooms

SPECIFICATIONS

GAGE SPECIFICATIONS
Service: Air and non-combustible, compatible gases.
Wetted Materials: Consult factory.
Accuracy: ±2% of FS (3000-0 ±3% of FS). (3000-00 ±4% of FS).
Pressure Limit: -20" Hg. to 25 psig (-0.677 bar to 1.72 bar). MP option: 35 psig (2.41 bar), HP option: 80 psig (5.52 bar).
Temperature Limits: 20 to 120°F (-6.67 to 48.9°C).
Process Connections: 1/8" female NPT (duplicated side and back).
Size: 4" (101.6 mm) dial face, 5" (127 mm) OD x 3-1/8" (79.38 mm); -SS bezel: 4-3/4" (120.7 mm) OD x 2-21/32 (67.5 mm).
Weight: 1.8 lb (816 g).

Electrical Connections: 18" (46 cm) cable assembly with 8 conductors. Optional lengths to 100' (30.5 m).
Power Requirements: 24 VDC, regulated ±10%.
Mounting Orientation: Diaphragm in vertical position. Consult factory for other position orientations.
Set Point Adjustment: Adjustable knobs on face.
Agency Approvals: CE.

SWITCH SPECIFICATIONS 3000MR
Switch Type: Each set point has 1 form C relays (SPDT).
Relay Contacts: (Resistive load) 1 form C rated 1.0A @ 30 VDC, 0.3A @ 110 VDC or 0.5A @ 125 VAC. Gold over clad silver - suitable for dry circuits.

SWITCH SPECIFICATIONS 3000MRS
Switch Type: Each set point has a solid state relay.
Switching Voltage: 20-280 VAC (47-63 Hz).
Switching Current: 1.0 amp (AC) max., 0.01 mA (AC) min., (2) SPST NO.
Electrical Connections: 18" (46 cm) cable assembly with 6 conductors, optional lengths to 100' (30.5 m).
Power Requirements: 24 VDC, regulated ±10%.
Mounting Orientation: Diaphragm in vertical position. Consult factory for other position orientations.
Set Point Adjustment: Adjustable knobs on face.
Agency Approvals: CE.

MODEL CHART

Model	Range, in w.c.	Minor Divs.	Model	Range, in w.c.	Minor Divs.
3000MR-00	0-0.25	.005	3000MRS-00**	0-0.25	.005
3000MR-0	0-0.5	.01	3000MRS-0*	0-0.5	.01
3001MR	0-1.0	.02	3001MRS	0-1.0	.02
3002MR	0-2.0	.05	3002MRS	0-2.0	.05
3003MR	0-3.0	.10	3003MRS	0-3.0	.10
3005MR	0-5.0	.10	3005MRS	0-5.0	.10
3010MR	0-10	.20	3010MRS	0-10	.20
3015MR	0-15	.50	3015MRS	0-15	.50
3020MR	0-20	.50	3020MRS	0-20	.50
3030MR	0-30	1.0	3030MRS	0-30	1.0
3050MR	0-50	1.0	3050MRS	0-50	1.0
3100MR	0-100	2.0	3100MRS	0-100	2.0
3000MR-60PA**	0-60	2.0	3000MRS-60PA**	0-60	2.0
3000MR-125PA*	0-125	5.0	3000MRS-125PA*	0-125	5.0
3000MR-250PA	0-250	5.0	3000MRS-250PA	0-250	5.0
3000MR-500PA	0-500	10.0	3000MRS-500PA	0-500	10.0
3000MR-1KPA	0-1.0	.02	3000MRS-1KPA	0-1.0	.02
3000MR-3KPA	0-3.0	.10	3000MRS-3KPA	0-3.0	.10
3000MR-4KPA	0-4.0	.10	3000MRS-4KPA	0-4.0	.10
3000MR-6MM**	0-6	.20	3000MRS-6MM**	0-6	.20
3000MR-10MM*	0-10	.50	3000MRS-10MM*	0-10	.50
3000MR-25MM	0-25	.50	3000MRS-25MM	0-25	.50
3000MR-50MM	0-50	1.0	3000MRS-50MM	0-50	1.0
3000MR-100MM	0-100	2.0	3000MRS-100MM	0-100	2.0
3000MR-20CM	0-20	.50	3000MRS-20CM	0-20	.50

*±3% of full-scale. **±4% of full-scale.
 Note: To order, select either MR or MRS suffix to Series 3000 number.
 Examples: 3001MR or 3001MRS

ACCESSORIES

Model	Description
A-298	Flat aluminum bracket for flush mounting 3000MR/MRS
A-370	Mounting bracket flush mount 3000MR/MRS bracket. Bracket is then surface mounted. Steel with gray hammertone epoxy finish
A-600	R/C snubber recommended for inductive loads like a solenoid or contactor

ACCESSORIES - STANDARD

Description
 Mounting ring, snap ring, 18" (45 cm) cable assembly, (2) 3/16" tubing to 1/8" NPT adapters, (2) 1/8" NPT pipe plugs, (4) 6-32 x 1-1/4" RH machine screws (panel mounting), (3) 6-32 x 5/16" RH machine screws (surface mounting)

OPTIONS

To order add suffix:	Description
-SS	304 brushed stainless steel bezel. *Backward compatible with standard Magnehelic® gage installation diameter
Example: 3001MR-SS	
-TAMP	Tamper-proof knobs; require spanner key (supplied) to change set points
-LT	Low temperature option; for use under 20°F (-6.7°C)
-MP	Medium pressure; increases maximum rated pressure to 35 psig (2.41 bar)
-HP	High pressure; increases maximum rated pressure to 80 psig (5.5 bar)
-WP	Weatherproof housing option
-NIST	NIST traceable calibration certificate
Example: 3001MR-NIST	

DIN RAIL DIFFERENTIAL PRESSURE TRANSMITTER

Mounts on 35 mm DIN Rail, $\pm 0.25\%$ Full-Scale Accuracy

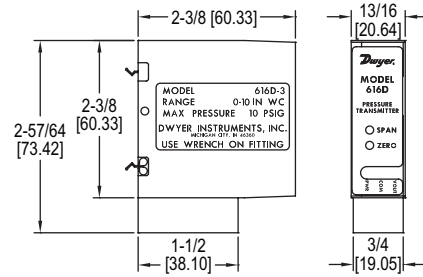

The Series 616D Din Rail Differential Pressure Transmitter senses the pressure of air and compatible gases and sends a standard 4-20 mA or 0-10 VDC output signal. The 616D enclosure is specifically designed to mount on a 35 mm DIN rail in a panel. This mounting style allows for several units to be mounted closely together reducing required space. The span and zero controls are for use when checking calibration. They are not intended for re-ranging. Versatile circuit design enables operation in 2-wire current loops.

FEATURES/BENEFITS

- Simple calibration push-buttons to set zero and span
- Cost effective and compact device suitable for OEM applications where space, simplicity, and value are key

APPLICATIONS

- Air handlers
- Variable air volume
- Duct pressure
- Filter monitoring

MODEL CHART		
Model	Range	Max. Pressure
616D-2	0 to 6 in w.c.	10 psig
616D-3	0 to 10 in w.c.	10 psig
616D-4	0 to 20 in w.c.	20 psig
616D-5	0 to 40 in w.c.	20 psig
616D-6	0 to 100 in w.c.	15 psig
616D-7	0 to 200 in w.c.	45 psig
616D-8	0 to 10 psid	45 psig

ACCESSORIES	
Model	Description
A-360	Aluminum DIN Rail 1 m

SPECIFICATIONS

Service: Air and non-combustible, compatible gases.
Wetted Materials: Consult factory.
Accuracy: $\pm 0.25\%$ FS @ 77°F (25°C).
Thermal Effect: ± 0.02 FS/°F ($\pm 0.036\%$ FS/°C).
Stability: $\pm 1\%$ FS/yr.
Temperature Limits: 14 to 185°F (-10 to 85°C).
Pressure Limits: See chart.
Power Requirements: 10-35 VDC (2-wire); 17-36 VDC, or isolated 21.6-33 VAC (3-wire).
Output Signal: 4-20 mA (2-wire); 0-10 VDC (3-wire).
Zero and Span Adjustments: Push-buttons.
Loop Resistance: Current output: 0 to 1250 Ω max; Voltage output: Load resistance 1 k Ω min.
Current Consumption: 40 mA max.
Electrical Connections: Screw-type terminal block.
Process Connections: 1/8" female NPT. Accessories included are 2 barbed fittings for 1/8" (3.12 mm) and 3/16" (4.77 mm) ID rubber or vinyl tubing.
Mounting Orientation: Vertical, on a 1.378" (35 mm) DIN rail.
Weight: 4.8 oz (136 g).
Agency Approvals: CE.

DIFFERENTIAL PRESSURE TRANSMITTERS ± 0.25 , ± 1 , OR $\pm 2\%$ ACCURACY

One-Touch® Digital Push-Button Calibration Technology

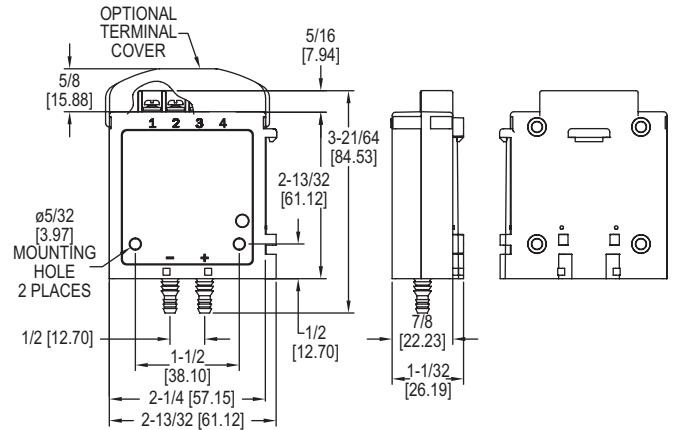
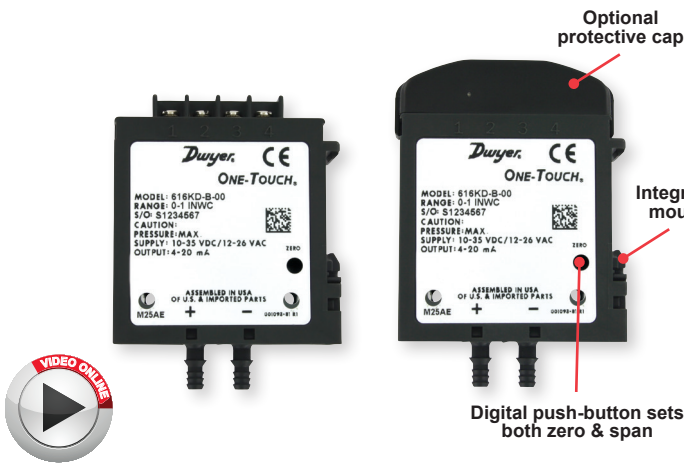

The Series 616KD Differential Pressure Transmitters ± 0.25 , ± 1 , or $\pm 2\%$ Accuracy with One-Touch® Digital Push-Button Calibration Technology are designed for simplicity, making them the ideal choice for installers and maintenance professionals. These instruments not only alleviate cumbersome turn pots typically found in most transmitters, but eliminate entirely the need to span the instruments during calibration. With a single digital push-button, both ZERO AND SPAN are calibrated properly, nothing else is required. No additional reference pressure sources or separate calibration devices are necessary.

FEATURES/BENEFITS

- Simple calibration push-button sets back zero and span, saving time installing and over the service life
- Cost effective and compact device suitable for OEM applications where space, simplicity, and value are key
- Ranges and accuracy selection cover a wide range of applications minimizing components and determining standardizing on design
- Optional 1/8" NPT process connection allows for use with metal barbed fittings or compression fittings for use with metal tubing
- Optional plenum rated units meeting UL Standard 2043 are available

APPLICATIONS

- Air handlers
- Variable air volume
- Duct pressure
- Filter monitoring

MODEL CHART					
Example	616KD	-A	-12	-AT	616KD-A-12-AT
Series	616KD				Differential pressure transmitter
Accuracy		A B			0.25% FS accuracy 1.0% FS accuracy 2.0% FS accuracy
Range			00 01 02 03 04 05 06 07 08 10 11 12 13 14 15 50 51 57 52 53 54 55 56 58		0 to 1 in w.c. 0 to 2 in w.c. 0 to 3 in w.c. 0 to 5 in w.c. 0 to 10 in w.c. 0 to 15 in w.c. 0 to 20 in w.c. 0 to 25 in w.c. 0 to 40 in w.c. 0 to 250 Pa 0 to 500 Pa 0 to 750 Pa 0 to 1250 Pa 0 to 2500 Pa 0 to 5000 Pa 0 to ± 1 in w.c. 0 to ± 2 in w.c. 0 to ± 3 in w.c. 0 to ± 5 in w.c. 0 to ± 10 in w.c. 0 to ± 250 Pa 0 to ± 500 Pa 0 to ± 750 Pa 0 to ± 1250 Pa
Options				AT FC NIST TC V N PR	Aluminum tag Factory calibration NIST certification Terminal cover Voltage output 0-5, 1-5, 0-10, 2-10 VDC (field selectable) 1/8" female NPT Plenum rated
Note: 0.25% FS accuracy is not available in the following ranges 00, 01, 10, 11, 50, 51, 54, 55					

SPECIFICATIONS

Service: Air and non-combustible, compatible gases.
Wetted Materials: Consult factory.
Accuracy: 616KD-A: $\pm 0.25\%$ FS; 616KD-B: $\pm 1\%$ FS, 616KD: $\pm 2\%$ FS.
Stability: $\pm 1\%$ FS/year.
Temperature Limits: 0 to 140°F (-17.8 to 60°C).
Compensated Temperature Range: 20 to 122°F (-6.67 to 50°C).
Pressure Limits: 2 psig (ranges 5 in w.c. or lower); 5 psig (ranges 10 to 40 in w.c.).
Thermal Effect: 616KD-A: $\pm 0.02\%$ FS/°F; 616KD-B: $\pm 0.04\%$ FS/°F; 616KD: $\pm 0.06\%$ FS/°F, includes zero and span.
Power Requirements: 4-20 mA output: 10-35 VDC (2 wire) or 12-26 VAC (4 wire); 5V output: 10-35 VDC (3 wire) or 12-26 VAC (4 wire); 10V output: 13-35 VDC (3 wire) or 12-26 VAC (4 wire) for 616KD A and B. 16-36 VDC (2 or 3 wire); 20-28 VAC (3 wire) for 616KD.
Output Signal: 4-20 mA or option with field selectable 0-10, 0-5, 2-10, 1-5 V.
Zero and Span Adjustments: Push button.
Loop Resistance: 4-20 mA output (DC): 0 to 1250 Ω max. Rmax = 50 (VpsDC -10) Ω ; 4-20 mA output (AC): 0 to 1200 Ω max. Rmax = 50 (1.4 VpsAC -12) Ω ; Voltage output: 5K Ω minimum.
Current Consumption: 24 mA max for 616KD A and B. 21 mA max for 616KD.
Electrical Connections: Screw-type terminal block.
Process Connections: Barbed, dual size to fit 1/8" & 3/16" (3 mm and 5 mm) ID rubber or vinyl tubing.
Enclosure Rating: NEMA 1 (IP20).
Mounting Orientation: Vertical with pressure connections pointing down.
Weight: 1.8 oz (51 g).
Agency Approvals: CE, optional plenum rated units meet UL Standard 2043.

ACCESSORIES

Model	Description
A-360	Aluminum DIN rail 1 m
A-618	Protective terminal cap



DIFFERENTIAL PRESSURE TRANSMITTERS - LOW RANGES

High Accuracy, Ranges Down to 0.1 in w.c. (25 Pa)

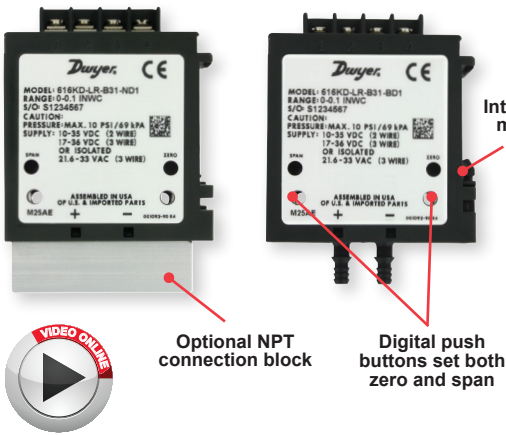

Optional NPT connection block

Digital push buttons set both zero and span

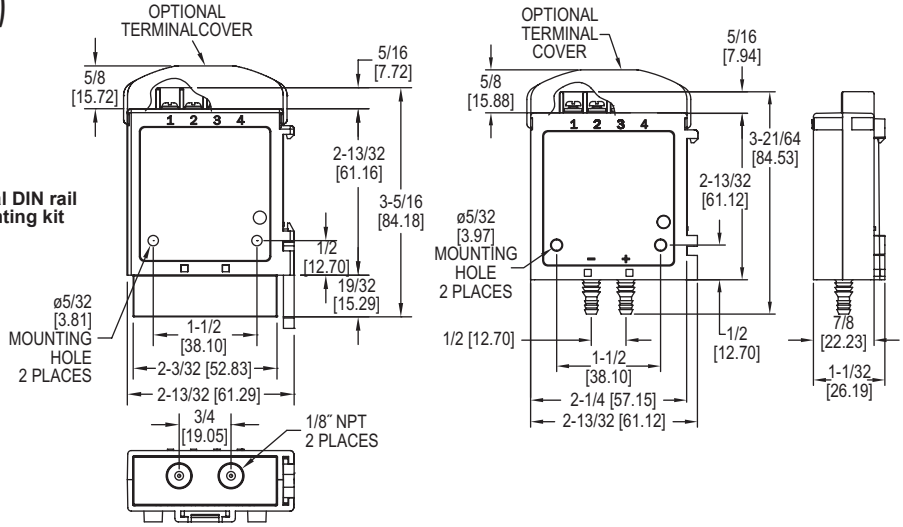

The Series 616KD-LR Differential Pressure Transmitters - Low Ranges are designed for simplicity, making it the ideal choice for installers and maintenance professionals. These low range instruments not only alleviate cumbersome turn pots typically found in most transmitters, but eliminate entirely the need to span the instruments during calibration. With single digital push-button, both ZERO AND SPAN are calibrated properly, nothing else is required. No additional reference pressure sources or separate calibration devices are necessary.

FEATURES/BENEFITS

- Wide selection of low ranges and accuracy cover numerous applications minimizing components and standardizing on design
- Simple calibration push-buttons to set zero and span, saving time installing and maintaining over the service life
- Cost effective and compact device suitable for OEM applications where space, simplicity, and value are key
- Simultaneous current and voltage outputs
- Optional 1/8" NPT process connection allows for use with metal barbed fittings or compression fittings for use with metal tubing
- Optional plenum rated units meeting UL Standard 2043 are available

APPLICATIONS

- Air handlers
- Variable air volume
- Duct pressure
- Filter monitoring

SPECIFICATIONS

Service: Air and non-combustible, compatible gases.
Wetted Materials: Consult factory.
Accuracy: ±0.25% FS for ±0.4" (100 Pa) and ±0.5" (125 Pa), ±0.5% FS for ±0.25" (60 Pa), and ±1% FS for ±0.1" (25 Pa).
Stability: ±1% / year FSO.
Temperature Limits: 0 to 140°F (-17.8 to 60°C).
Pressure Limits: 1 psi max., operation; 10 psi burst.
Power Requirements: 10-35 VDC (2 wire), 17-36 VDC or isolated 21.6-33 VAC (3 wire).
Output Signal: 4-20 mA (2-wire), 0-5 VDC, 0-10 VDC (3-wire).
Response Time: 2.5 Hz sample rate.

Zero and Span Adjustments: Push buttons.
Loop Resistance: Current Output: 0 to 1250Ω max; Voltage Output: Min. load resistance 1kΩ.
Current Consumption: 40 mA max.
Electrical Connections: Screw-type terminal block.
Process Connections: Barbed, dual size to fit 1/8" & 3/16" (3 mm & 5 mm) ID rubber or vinyl tubing, or 1/8" NPT.
Enclosure Rating: NEMA1 (IP20).
Mounting Orientation: Vertical with pressure connections pointing down.
Weight: 1.8 oz (51 g).
Agency Approvals: CE, optional plenum rated units meet UL Standard 2043.

MODEL CHART							
Example	616KD-LR	-A	34	-B	D1	-FC	616KD-LR-A34-BD1-FC
Series	616KD-LR						Differential pressure transmitter
Accuracy		A B D					0.25% FS accuracy 1.0% FS accuracy 0.5% FS accuracy
Range			31 32 34 35 41 42 44 45 61 62 64 65 71 72 74 75				0 to 0.1 in w.c. ① 0 to 0.25 in w.c. ② 0 to 0.4 in w.c. 0 to 0.5 in w.c. 0 to ±0.1 in w.c. ① 0 to ±0.25 in w.c. ② 0 to ±0.4 in w.c. 0 to ±0.5 in w.c. 25 Pa ① 60 Pa ② 100 Pa 125 Pa 0 to ±25 Pa ① 0 to ±60 Pa ② 0 to ±100 Pa 0 to ±125 Pa
Process Connection				B N			Plastic barb 1/8" female NPT with front push-button
Output					D1 D2 D3 D4		4-20 mA and 0-10 V 4-20 mA and 0-5 V 4-20 mA and 2-10 V 4-20 mA and 1-5 V
Options						AT COC FC NIST TC PR	Aluminum tag Certificate of Conformance Factory calibration certificate NIST traceable calibration certificate Terminal cover Plenum rated

①B accuracy only. ②B and D accuracies only.

ACCESSORIES	
Model	Description
A-360	Aluminum DIN rail 1 m
A-618	Protective terminal cap

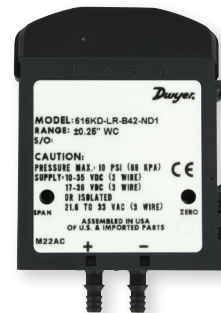

A-618 installed on unit

Dwyer
SERIES 647

WET/WET DIFFERENTIAL PRESSURE TRANSMITTER

±1.0% Accuracy, NEMA 4 (IP56) Enclosure, 2-Wire

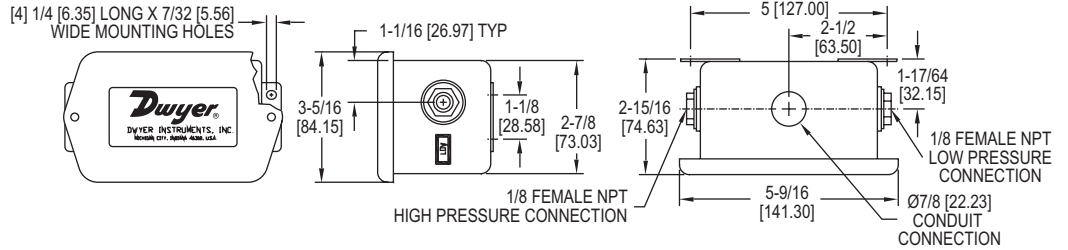

Monitor differential pressure in air/liquid flow systems, HVAC automation, pneumatic systems and process control with the **Series 647 Wet/Wet Differential Pressure Transmitter**. Units are temperature compensated and provide a 4-20 mA output signal which can be interfaced with chart recorders, data loggers and computerized monitoring and control systems.

FEATURES/BENEFITS

- Versatile for liquid or gas supports designs requiring more precise measurements in support of application
- Temperature compensated improves performance of device for accurate measurement under different operating environments.
- Output signal provides capability to interface with automation systems to centralize monitoring

APPLICATIONS

- Flow
- HVAC automation
- Process control
- Pneumatic systems

SPECIFICATIONS

Service: Compatible gases or liquids on both pressure and reference sides.
Wetted Materials: Brass, vinyl, glass-filled polyester, silicon, and fluorosilicone.
Accuracy: ±1.0% FS.
Stability: ±1.5% FS output/year.
Temperature Limits: 32 to 122°F (0 to 50°C).
Pressure Limits: Ranges 1 in w.c. to 5 psi: 20 psi, 15 psi range: 45 psi, 30 psi range: 60 psi.
Thermal Effects: Zero: ±0.05% FS/°F, Span: ±0.05% rdg/°F.
Power Requirements: 18-30 VDC.
Output Signal: 4-20 mA, 2-wire.
Zero and Span Adjustments: Adjustable, ±10%.
Loop Resistance: 400Ω @ 18 VDC, 600Ω @ 24 VDC, 1000Ω @ 30 VDC.
Electrical Connection: Screw terminals, reverse polarity protected.
Process Connections: Two 1/8" female NPT.
Housing: Gasketed steel epoxy painted, NEMA 4 (IP56).
Weight: 14 oz (397 g).

MODEL CHART	
Model	Range
647-0	0 to 1 in w.c.
647-1	0 to 3 in w.c.
647-2	0 to 25 in w.c.
647-3	0 to 5 in w.c.
647-4	0 to 10 in w.c.

OPTIONS	
Use order code:	Description
NISTCAL-PT1	NIST traceable calibration certificate

WET/WET DIFFERENTIAL PRESSURE SWITCH

NEMA 4X Enclosure, Low Differential Set Points

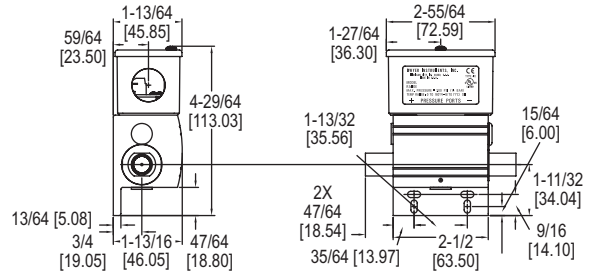
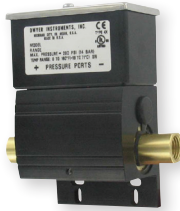

The **Series DX Wet/Wet Differential Pressure Switch** makes a contact output based on the differential between two pressure sources. Wetted materials of brass and fluoroelastomer are suitable for use with most gases and water based solutions. The switch can be used for low differential pressure indication with set point on a decrease of pressure as low as 1 psid (0.07 bar). Differential set point ranges are available from 2.5 to 75 psid (0.17 to 5.17 bar) on increasing differential pressure and 1.0 to 67 psid (0.07 to 4.62 bar) on decreasing differential pressure. Unit features a high static pressure rating of 200 psig (13.8 bar). Weatherproof, UL type 4X, enclosure for dust laden, outdoor, or wash-down installation environments. Externally adjustable set point, integral mounting flange and a removable electrical terminal block for quick and easy installation.

FEATURES/BENEFITS

- Differential pressure switch that is suitable for most gas and water-based applications allows multiple uses in the most sophisticated designs
- Weatherproof housing provides protection in the harsh, wet or dirty environments ensuring switch's long-service life
- Removable terminal block reduces installation time

APPLICATIONS

- Indicating filter condition
- Proof of flow indicator monitoring
- Proving flow through a pump
- Proving flow through a chiller
- Proving flow through a heat pump or AC unit

Model	Adjustable Differential Range (on increase) [psid (bar)]	Fixed Deadband [psid (bar)]	
		Low Set Point	High Set Point
DXW-11-153-1	2.5 to 10 (0.17 to 0.69)	1.5 (0.10)	2.5 (0.17)
DXW-11-153-2	10 to 25 (0.69 to 1.72)	2.5 (0.17)	3.5 (0.24)
DXW-11-153-3	25 to 50 (1.72 to 3.45)	3.5 (0.24)	6.0 (0.41)
DXW-11-153-4	50 to 75 (3.46 to 5.17)	6.0 (0.41)	8.0 (0.55)

Note: Set points on decrease will be the range minus the deadband.

OPTIONS	
To order add suffix:	Description
-PRESET	Preset unit
Example: DXW-11-153-1-PRESET	

SPECIFICATIONS

- Service:** Compatible gases and liquids.
- Wetted Materials:** Connection: Brass; Diaphragm: Fluoroelastomer.
- Temperature Limits:** 30 to 140°F (-1 to 60°C).
- Pressure Limits:** 200 psig (13.8 bar). Continuous single side only pressure should not exceed 1.25 x full differential range.
- Enclosure Rating:** Weatherproof UL type 4X (IP65).
- Repeatability:** ±2% of full range.
- Switch Type:** SPDT snap switch.
- Electrical Rating:** 5 A @ 125/250 VAC (~), 5 A res. @ 30 VDC (---).
- Electrical Connection:** Removable terminal block.
- Conduit Connection:** 0.871" diameter hole for 1/2" conduit fitting.
- Process Connection:** 1/4" NPT female.
- Mounting Orientation:** Ports on horizontal plane, ±10°.
- Set Point Adjustment:** External screw.
- Housing Materials:** Body: Aluminum; Housing: Polycarbonate; Cover: 300 SS.
- Vibration and Shock:** Set point repeats after 2.5 Gs, 5 to 500 Hz. Set point repeats after a 15 Gs, 10 millisecond duration.
- Humidity Limit:** 80% (non-condensing).
- Pollution Degree:** 2.
- Environment:** Intended for indoor and outdoor use.
- Weight:** 1 lb 3 oz (0.54 kg).
- Agency Approvals:** CE, cULus.

COMPACT DIFFERENTIAL PRESSURE TRANSMITTERS

Ranges from 0.1 to 100 in w.c., Overpressure Protection to 15 psig, ±0.8% Accuracy



668B



668D

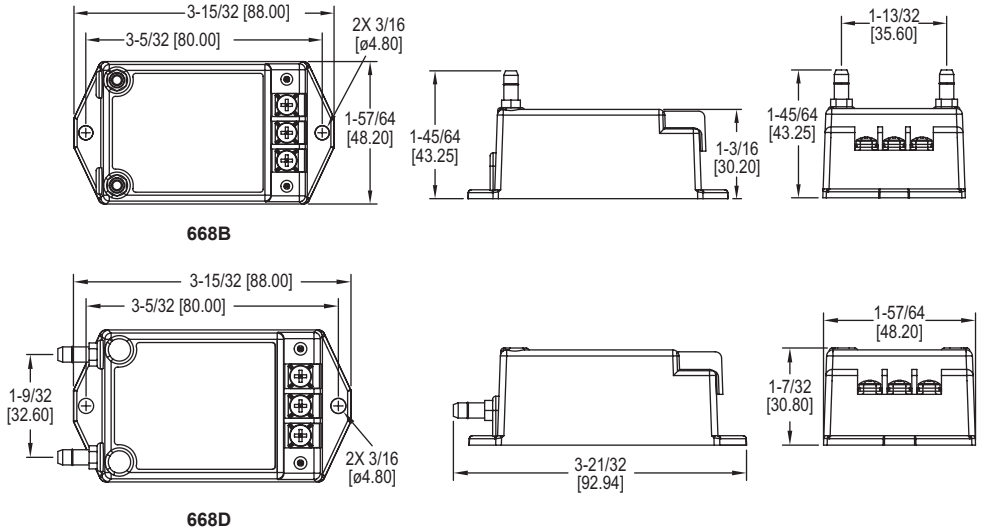

Our low cost **Series 668B/D Compact Differential Pressure Transmitters** are capable of sensing differential gage pressure with ±0.8% FS accuracy, and converts this pressure difference to a proportional high level analog output for both unidirectional and bi-directional pressure ranges. These transmitters can withstand up to 15 psig overpressure with no damage to the unit. The compact, lightweight design makes installation simple and easy. Units are protected against incorrect wiring, and include a protective terminal cover.

FEATURES/BENEFITS

- Protection from 15 psi overpressure & incorrect wiring
- High accuracy at low pressure ranges
- Two package selections allows easy device mounting to best fit application pressure connections

APPLICATIONS

- HVAC and VAV control
- Clean rooms and isolation rooms
- Duct static pressure measurement

SPECIFICATIONS

Service: Air and non-conductive gases.
Accuracy: ±0.8% FS.
Temperature Limits: Operating: 0 to 170°F (-18 to 77°C); Storage: -40 to 185°F (-40 to 85°C).
Pressure Limits: 15 psig (1.0 bar).
Thermal Effects: ±0.03% FS/°F (±0.054% FS/°C).
Compensated Range: From 40 to 170°F (4.4 to 77°C).
Power Requirements: 12-32 VDC.
Output Signals: 4-20 mA (2-wire), 0-10 VDC (3-wire), or 0-5 VDC (3-wire).
Zero Adjustment: Accessible under the small terminal cover.
Electrical Connection: Terminal strip.
Process Connection: 3/16" OD barbed brass for 1/8" ID push-on tubing.
Enclosure: Stainless steel and PC+ABS alloy, UL 94 V-0 rated.
Weight: 4.0 oz (113 g).

MODEL CHART					
Example	668	B	-08	-1	668B-08-1
Series	668				Compact differential pressure transmitter
Connection		B			Front
		D			Bottom
Unidirectional Pressure Ranges			01		0 to 0.1 in w.c.
			21		0 to 0.2 in w.c.
			02		0 to 0.25 in w.c.
			22		0 to 0.4 in w.c.
			03		0 to 0.5 in w.c.
			04		0 to 1 in w.c.
			05		0 to 2.5 in w.c.
			06		0 to 5 in w.c.
			07		0 to 10 in w.c.
			08		0 to 25 in w.c.
			09		0 to 50 in w.c.
			10		0 to 100 in w.c.
			12		0 to ±0.1 in w.c.
			13		0 to ±0.25 in w.c.
			14		0 to ±0.5 in w.c.
			15		0 to ±1 in w.c.
			16		0 to ±2.5 in w.c.
			17		0 to ±5 in w.c.
			18		0 to ±10 in w.c.
		19		0 to ±25 in w.c.	
Output			1		4-20 mA
			2		0-10 VDC
			3		0-5 VDC

ACCESSORIES	
Model	Description
A-TC	Replacement protective terminal cover

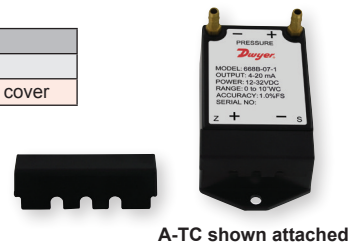

A-TC shown attached

OPTIONS	
Use order code:	Description
NISTCAL-PT1	NIST traceable calibration certificate

USA: California Proposition 65
 ⚠️WARNING: Cancer and Reproductive Harm - www.P65Warnings.ca.gov

HVAC DIFFERENTIAL PRESSURE SWITCHES

With Dual Scale Field Adjustable Set Point Knob

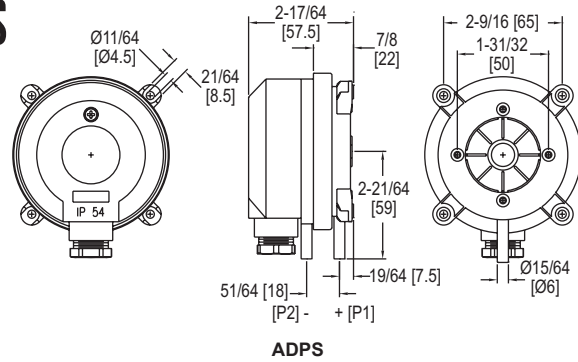
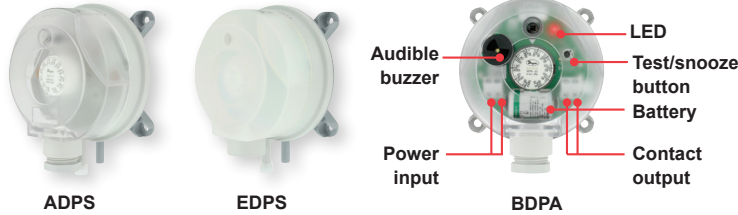

ADPS

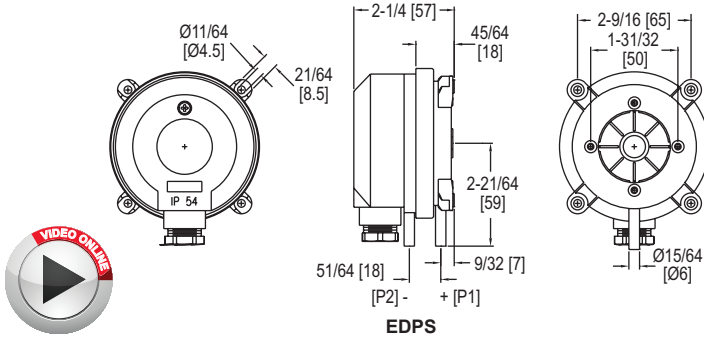

EDPS

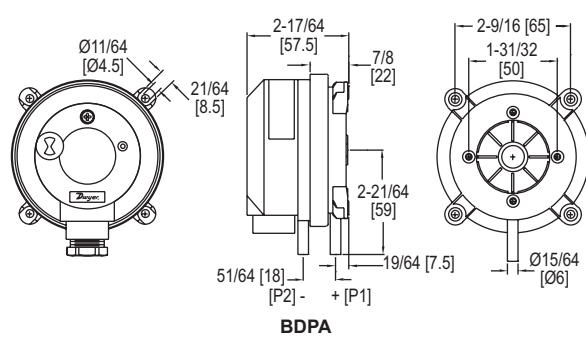

BDPA

The Series ADPS/EDPS/BDPA HVAC Differential Pressure Switches are designed for pressure, vacuum, and differential pressures. The dual scaled adjustment knob in inches water column and pascals allows changes to the switching pressure to be made without a pressure gage. The ADPS/EDPS/BDPA are available with settings from 0.08 in w.c. (20 Pa) up to 20 in w.c. (5000 Pa). The silicone diaphragm and PA 6.6 body make the series ADPS ideal for use with air and other noncombustible gases. Series EDPS models meet UL508 and are constructed of plenum rated plastics. The series BDPA Adjustable Differential Pressure Alarms offer a versatile range of configurations allowing utilization of their many features including buzzer and LED notification, and battery or line powered. The compact size, adjustment knob and low cost make the ADPS/EDPS/BDPA the perfect choice for HVAC applications.

FEATURES/BENEFITS

- Adjustment knob changes switching pressure easily with a pressure gage reducing components for application
- Low cost device makes it an excellent solution in BAS and HVAC applications requiring duct control and monitoring
- Relay contact allows simple integration with DDC or building systems

APPLICATIONS

- Air filter and ventilator monitoring
- Industrial cooling circuits
- Fire-protection damper control
- Ventilation duct monitoring
- Fan heater overheating protection
- Heat exchanger frost protection

SPECIFICATIONS

Service: Air and non-combustible, compatible gases.
Wetted Materials: ADPS: Diaphragm material: Silicone; Housing material: POM; Switch body: PA 6.6; Cover: Polystyrene; EDPS: Diaphragm material: Silicone; Housing material: Switch body: PA 6.6; Cover: Polystyrene; Materials UL 94 V-0 rated.
Temperature Limits: Process and ambient temperature from -4 to 185°F (-20 to 85°C).
Pressure Limits: Max. operating pressure: 40 in w.c. (10 kPa) for all pressure ranges.
Switch Type: Single-pole double-throw (SPDT).
Electrical Rating: Max. 1.5 A res./0.4 A ind./250 VAC, 50/60 Hz; Max. switching rate: 6 cycles/min.
Electrical Connections: Push-on screw terminals. M20x1.5 with cable strain relief or optional 1/2" NPT.
Process Connections: 5/16" (7.94 mm) outside diameter tubing, 1/4" (6.0 mm) inside diameter tubing.
Enclosure Rating: NEMA 13 (IP54).
Mounting Orientation: Vertically, with pressure connections pointing downwards.
Mechanical Working Life: Over 10⁶ switching operations.
Weight: 5.6 oz (160 g).
Agency Approvals: ETL approved to UL508 and CSA C22.2#14 (EDPS only).

MODEL CHART - ADPS			
Model	Set Point Range in w.c. (Pa)	Approx. Dead Band @ Min Set Point in w.c. (Pa)	Approx. Deadband @ Max Set Point in w.c. (Pa)
ADPS-08-2-N	0.08 to 1.20 (20-300)	0.04 (10)	0.05 (12)
ADPS-04-2-N	0.12 to 1.60 (30-400)	0.06 (15)	0.09 (23)
ADPS-03-2-N	0.20 to 2.00 (50-500)	0.08 (20)	0.09 (23)
ADPS-05-2-N	0.80 to 4.00 (200-1000)	0.4 (100)	0.5 (130)
ADPS-06-2-N	2.00 to 10.00 (500-2500)	0.6 (150)	0.8 (200)
ADPS-07-2-N	4.00 to 20.00 (1000-5000)	1.0 (250)	1.4 (350)

Note: For optional 1/2" NPT conduit connection, change -2-N to -1-N. Models that include installer kit add -C to the end of the model number (-2-N cable gland models only). Installer kit includes two static tips and 7 ft of PVC tubing. Order installer kit separately with 1/2" NPT conduit connection models. See A-481 in the accessories list. Consult factory for bulk packaging option.

MODEL CHART - EDPS			
Model	Set Point Range in w.c. (Pa)	Approx. Dead Band @ Min Set Point in w.c. (Pa)	Approx. Dead Band @ Max Set Point in w.c. (Pa)
EDPS-08-1-N	0.08 to 1.20 (20-300)	0.04 (10)	0.05 (12)
EDPS-04-1-N	0.12 to 1.60 (30-400)	0.06 (15)	0.09 (23)
EDPS-03-1-N	0.20 to 2.00 (50-500)	0.08 (20)	0.09 (23)
EDPS-05-1-N	0.80 to 4.00 (200-1000)	0.4 (100)	0.5 (130)
EDPS-06-1-N	2.00 to 10.00 (500-2500)	0.6 (150)	0.8 (200)
EDPS-07-1-N	4.00 to 20.00 (1000-5000)	1.0 (250)	1.4 (350)

Note: For optional M20 cable gland connection, change -1-N to -2-N.

MODEL CHART - BDPA			
Model	Set Point Range in w.c. (Pa)	Approx. Dead Band @ Min Set Point in w.c. (Pa)	Approx. Dead Band @ Max Set Point in w.c. (Pa)
BDPA-08-2-N	0.08 to 1.20 (20 to 300)	0.04 (10)	0.05 (12)
BDPA-04-2-N	0.12 to 1.60 (30 to 400)	0.06 (15)	0.09 (23)
BDPA-03-2-N	0.20 to 2.00 (50 to 500)	0.08 (20)	0.09 (23)
BDPA-05-2-N	0.80 to 4.00 (200 to 1000)	0.4 (100)	0.5 (130)
BDPA-06-2-N	2.00 to 10.00 (500 to 2500)	0.6 (150)	0.8 (200)
BDPA-07-2-N	4.00 to 20.00 (1000 to 5000)	1.0 (250)	1.4 (350)

ACCESSORIES	
Model	Description
A-288	"L" type metal mounting bracket with screws
A-289	"S" type metal mounting bracket with screws
A-480	Plastic static pressure tip
A-481	Installer kit, includes 2 plastic static pressure tips & 7' (2.1 m) of PVC tubing
A-489	4" straight static pressure tip with flange



A-480

COMPACT LOW DIFFERENTIAL PRESSURE SWITCHES

Set Points from 0.07 to 20 in w.c. Repetitive Accuracy within 3%

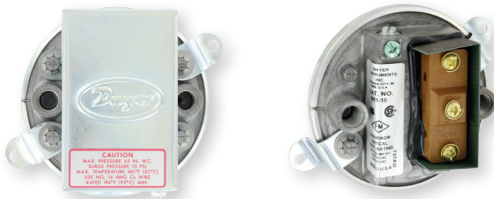

Series 1910 switch with conduit enclosure off.
Shows electric switch and set point adjustment screw located on same side for easy installation.

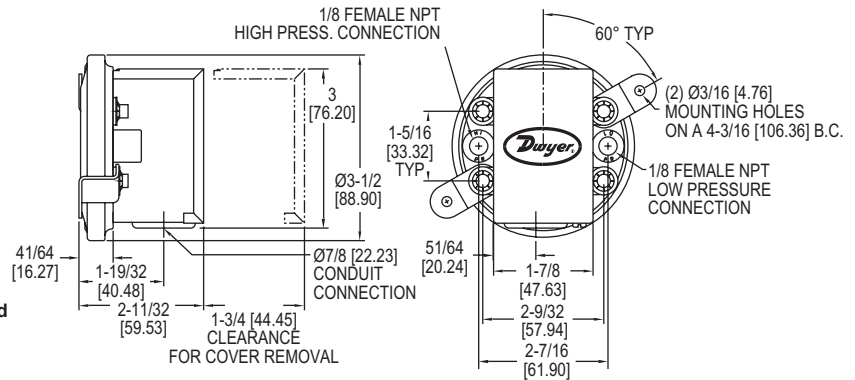

The Dwyer-engineered force-motion amplifier increases the leverage of diaphragm movement and results in a switch with excellent sensitivity and repeatability.

Our most popular **Series 1900 Compact Low Differential Pressure Switches** combine advanced design and precision construction to make these switches able to perform many of the tasks of larger, costlier units. Designed for air conditioning service, they also serve many fluidics, refrigeration, oven and dryer applications. Series 1900 switches have set points from 0.07 to 20 in w.c. (1.8 to 508 mm). Set point adjustment is easy with range screw located inside conduit enclosure. Internal location helps prevent tampering. UL, CE and CSA listed, and FM approved. For use with air or compatible gages.

FEATURES/BENEFITS

- Compact size and repeatability, provides a high-value switch for many industrial and OEM applications
- Wide range of models from 0.07 in w.c. to 20 in w.c. can meet exacting OEM specifications for a low pressure switch
- Range screw protected inside enclosure provides simplifies making adjustments but prevents tampering

APPLICATIONS

- Air conditioning refrigeration coil icing detection; defrost cycle initiation
- Clogged filter detection
- Variable air volume controller

SPECIFICATIONS	
Service:	Air and non-combustible, compatible gases.
Wetted Materials:	Consult factory.
Temperature Limits:	-30 to 180°F (-34 to 82.2°C).
Pressure Limits:	45 in w.c. (11.2 kPa) continuous, 10 psig (68.95 kPa) surge.
Switch Type:	Single-pole double-throw (SPDT).
Repeatability:	±3%.
Electrical Rating:	15 A @ 120-480 VAC, 60 Hz. Resistive 1/8 HP @125 VAC, 1/4 HP @ 250 VAC, 60 Hz. Derate to 10 A for operation at high cycle rates.
Electrical Connections:	3 screw type, common, normally open and normally closed.
Process Connections:	1/8" female NPT.
Mounting Orientation:	Diaphragm in vertical position. Consult factory for other position orientations.
Set Point Adjustment:	Screw type inside conduit enclosure.
Weight:	1 lb 4.5 oz (581 g).
Agency Approvals:	CE, CSA, FM, and UL. Optional-EXPL explosion-proof enclosure does not possess any agency approvals.

MODEL CHART			
Model	Operating Range in w.c.	Approximate Deadband	
		At Min. Set Point	At Max. Set Point
1910-00	0.07 to 0.15	0.04	0.04
1910-0	0.15 to 0.5	0.10	0.10
1910-1	0.40 to 1.6	0.15	0.16
1910-5	1.40 to 5.5	0.30	0.30
1910-10	3.0 to 11.75	0.40	0.40
1910-20	4.0 to 20.0	0.40	0.50

ACCESSORIES	
Model	Description
A-399	Duct pressure monitor kit; for use with standard or manual reset model switches; includes mounting flange, tubing and adapters
A-329	Street ell; brass adapter for applications requiring right angle connections; two required for differential pressures
A-302F-A	303 SS static pressure tip with mounting flange; for 3/16" ID rubber or plastic tubing; 4" insertion depth; includes mounting screws
A-489	4" straight static pressure tip with flange

OPTIONS	
Weatherproof Housing	
16 ga. steel enclosure with gasketed cover (NEMA 4, IP66) for wet or oily conditions. Withstands 200 hour salt spray test. Wt. 5-1/2 lb (2.5 kg). Switch must be factory installed.	
Note: To order, change 1910 base number to 1911, add -WP suffix.	
Example: 1911-1-WP	
Explosion-Proof Housing	
Cast iron base with brass cover. Rated Class I, Groups D; Class II, Div. 2, Groups E, F, G; Class III and NEMA 7, 9 NEMA 3. (7 lb). Switch must be factory installed.	
Note: To order, change 1910 base number to 1911, add -EXPL suffix.	
Example: 1911-1-EXPL	
Manual Reset Option (Model 1900 MR)	
Includes special snap switch which latches on pressure increase above the setpoint. Switch must be manually reset after pressure drops below the setpoint. Available on -1, -5, -10 or -20 ranges only. Option is not UL, CSA or FM listed. For use only in single positive pressure applications.	
Note: To order, change 1910 base number to 1900, add -MR suffix.	
Example: 1900-10-MR	



Manual reset option

USA: California Proposition 65
⚠WARNING: Cancer and Reproductive Harm - www.P65Warnings.ca.gov

Process Tubing Options: See page 93 (Gage Tubing Accessories)

DPDT LOW DIFFERENTIAL PRESSURE SWITCHES

Manual Reset, No Power Required

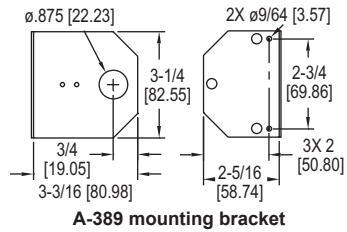
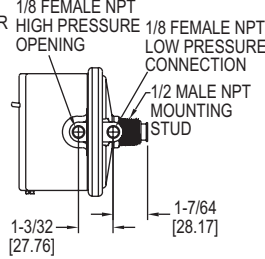
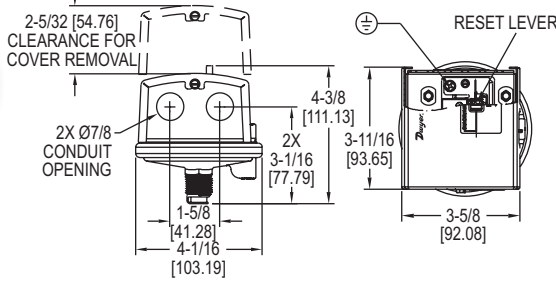

Note: Shown with included mounting bracket. Bracket can rotate and be tightened at any angle.

One of our most popular differential pressure switches is now available with a DPDT switch and manual reset. The **Series 1831 DPDT Low Differential Pressure Switches** combine small size with 4% set point repeatability. Absolutely no power is required to operate the DPDT switch. Set point adjustment on the switch is easily accessible for modifying the set point. The Series 1831 DPDT Low Differential Pressure Switches with Manual Reset eliminate common problems associated with typical high duct static cutout installations. Since the 1831 requires absolutely no power to drive its outputs, a separate power loop and its associated additional wiring and conduit is alleviated, reducing material and labor installation costs. Both control contacts of the Series 1831 activate at the same time. The potential of the lead switch shutting down the fan preventing the lag switch from sending an alarming signal to the DDC is no longer a probable system liability. Potential costly maintenance calls are diminished. Unlike typical switches that possess only a single conduit entry for both control loops, the Series 1831 provides two conduit connections simplifying wiring while eliminating additional conduit tees.

- | | |
|---|---|
| <p>FEATURES/BENEFITS</p> <ul style="list-style-type: none"> No power to operate DPDT switch means no additional wiring or conduit reduces material and installation labor costs Easy access for modifying set point simplifies adjustment Both control contacts activate at the same time eliminating system issues where lead switch activities prevent the lagging switch from sending a signal | <p>APPLICATIONS</p> <ul style="list-style-type: none"> High duct static cutout applications HVAC |
|---|---|

MODEL CHART		
Model	Description	Range (in w.c.)
1831-1-RA-S	Manual reset DPDT, activate on increase	2.5 to 9
1831-2-RA-S	Manual reset DPDT, activate on increase	7.5 to 23

SPECIFICATIONS	
Service: Air and non-combustible, compatible gases.	Electrical Rating: 4 A @ 125/250 VAC.
Wetted Materials: Consult factory.	Electrical Connections: Screw type terminal block.
Temperature Limits: -30 to 180°F (-34 to 82.2°C).	Process Connections: 1/8" female NPT.
Pressure Limits: 10 psig (68.95 kPa) continuous, 25 psig (172.4 kPa) surge.	Mounting Orientation: Diaphragm in vertical position. Consult factory for other position orientations.
Switch Type: 2 SPDT.	Set Point Adjustment: Screw type inside mounting spud.
Actuation Time Difference: 1 millisecond maximum actuation delay between contacts.	Weight: 1 lb 2 oz (522 g).
Repeatability: ±4% max.	

ACCESSORIES	
Model	Description
A-489	4" straight static pressure tip with flange
A-491	6" straight static pressure tip with flange
A-493	8" straight static pressure tip with flange
A-302F-A	303 SS static pressure tip with mounting flange; for 3/16" ID rubber or plastic tubing; 4" insertion depth; includes mounting screws
A-302F-B	303 SS static pressure tip with mounting flange; for 3/16" rubber or plastic tubing; 6" insertion depth; includes mounting screws
A-302F-C	303 SS static pressure tip with mounting flange; for 3/16" rubber or plastic tubing; 8" insertion depth; includes mounting screws

Process Tubing Options: See page 93 (Gage Tubing Accessories)

SERIES 645

WET/WET DIFFERENTIAL PRESSURE TRANSMITTERS

±0.25% Accuracy, Quick Response, 2-Wire Design

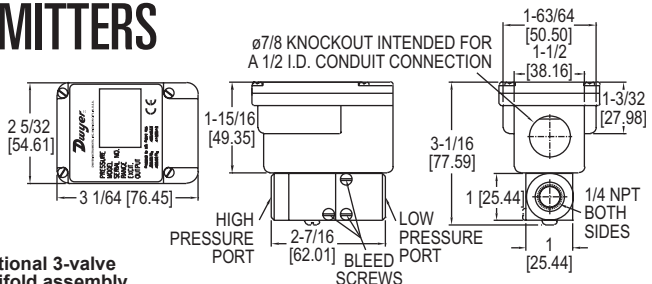
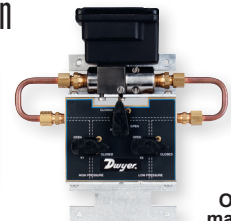

Series 645 Wet/Wet Differential Pressure Transmitters are designed for use with compatible gases and liquids which can be applied to both the pressure and reference ports. Quick response capacitance sensor delivers a 4-20 mA output signal proportional to differential pressure with ±.25% accuracy. The Series 645 transmitters are ideal for process control, filter condition monitoring, refrigeration equipment, pump speed control, HVAC equipment, and liquid level measurement. For ease of installation and maintenance, order optional 3-valve manifold assembly. Bleed ports allow for total elimination of air in the line and pressure cavities.

- | | |
|--|--|
| <p>FEATURES/BENEFITS</p> <ul style="list-style-type: none"> Versatile, high-accuracy device for liquid or gas supports designs requiring more precise measurements in support of application Optional 3-way valve manifold supports simplifying installation or removal of transmitter without interrupting process | <p>APPLICATIONS</p> <ul style="list-style-type: none"> Process control Refrigeration equipment HVAC equipment Filter monitoring Pump speed control Liquid level measurement |
|--|--|

MODEL CHART			
Model	Range	Model	Range
645-0	0 to 1 psid	645-4	0 to 25 psid
645-1	0 to 2 psid	645-5	0 to 50 psid
645-2	0 to 5 psid	645-6	0 to 100 psid
645-3	0 to 10 psid		

Note: For optional 3-valve manifold assembly, add -3V to end of model number.

OPTIONS	
Use order code:	Description
NISTCAL-PT1	NIST traceable calibration certificate

SPECIFICATIONS	
Service: Compatible gases or liquids on both pressure and reference sides.	Zero and Span Adjustments: Adjustable, ±1 mA, non-interactive.
Wetted Materials: 17-4 PH stainless steel, 300 Series stainless steel, fluoroplastic and silicone O-rings and bleed screw seals.	Response Time: 30 to 50 ms.
Accuracy: ±0.25% FS (RSS).	Loop Resistance: 0 to 1000Ω.
Temperature Limits: Operating: 0 to 175°F (-22 to 80°C); Storage: -65 to 260°F (-54 to 126°C).	Electrical Connection: Barrier strip terminal block with conduit enclosure and .875" (22 mm) diameter conduit opening.
Pressure Limits: (High side) 1 to 5 psi: 20 x FS, 10 to 25 psi: 10 x FS, 50 psi: 5 x FS, 100 psi: 2.5 x FS; (low side) 2.5 x FS.	Process Connection: 1/4"-18 female NPT.
Thermal Effects: (includes zero and span) ±0.02% FS/°F, 30 to 150°F (-1 to 65°C).	Housing: Stainless steel/aluminum, NEMA 4X (IP56).
Power Requirements: 11-30 VDC.	Weight: 14.4 oz (0.4 kg).
Output Signal: 4-20 mA, 2-wire.	Agency Approvals: CE.

3-VALVE MANIFOLD ASSEMBLY
Manifold: Brass.
Valve Type: 90° on/off.
Process Connection: 1/4"-18 female NPT.

DIFFERENTIAL PRESSURE TRANSMITTERS

High Accuracy, IP65 Enclosure

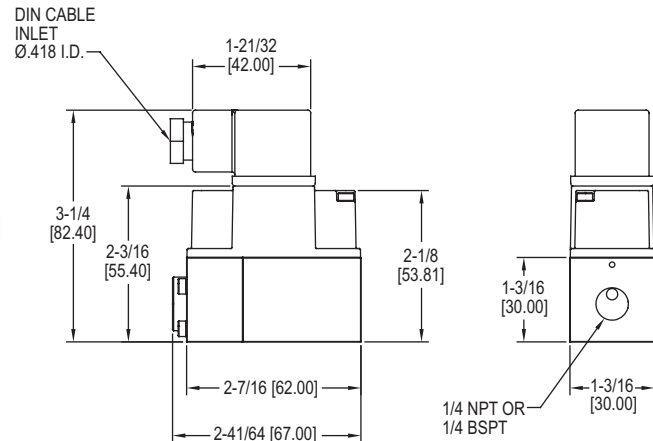
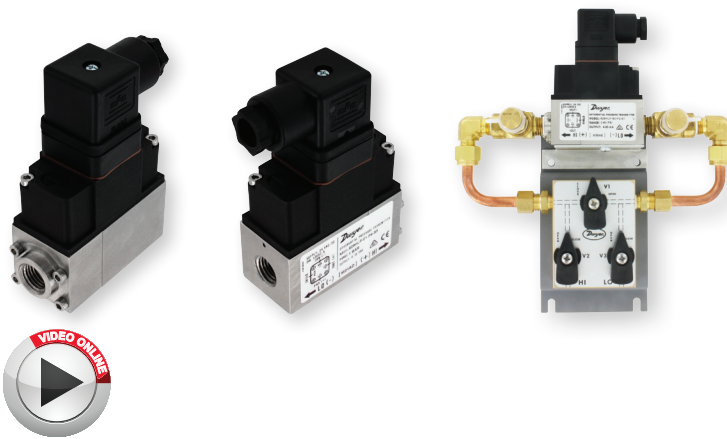

The **Series 629HLP Differential Pressure Transmitters** are suitable for measuring over-pressure, under-pressure, and differential pressure in compatible gases and liquids with 1% accuracy. The 629HLP is suitable for all measuring tasks in commercial, industrial or sanitary applications. Its single sensor design, allows it to measure small increment pressure changes, and converts them to a linear analog output signal from 4-20 mA or 0-10 VDC.

FEATURES/BENEFITS

- Rugged, versatile, high accuracy device
- For liquid or gas systems requiring precise measurements
- Provide excellent response and reliability
- Suitable for static and dynamic measurements
- Converts pressure changes into 4-20 mA or 0-10 VDC output
- Compact, lightweight, capable to be installed in any arrangement making installation very simple

APPLICATIONS

- Heat exchangers
- Fan coils/air handlers
- Core testing applications
- Hydraulic systems
- High line pressures/low DP
- Pumps
- Commercial/industrial processes
- Sanitary process

SPECIFICATIONS

Service: Compatible gases or liquids.
Wetted Material: 304 SS, EPDM, silicone grease, alumina ceramic; Optional 3-way valve: Brass, copper, nylon, HNBR, FKM, NBR.
Housing Material: ABS.
Enclosure Rating: IP65.
Accuracy: ±1% from -5 to 60°C (23 to 140°F).
Stability: ±1% FS/year.
Temperature Limits: Ambient: -10 to 60°C (14 to 122°F); Process: -10 to 80°C (14 to 176°F).
Relative Humidity: 10% to 90% non-condensing.
Installation Position: Not position sensitive.
Pressure Limits: See pressure range limits chart.
Burst Pressure: See pressure range limits chart.
Static Pressure Limits: See pressure range limits chart.
Output Signal: 4-20 mA, 0-10 VDC.
Response Time: 50 ms.
Rated Supply Voltage: 0-10 VDC output: 12-36 VDC or 12-32 VAC (@ max load of 2k Ω) 4-20 mA output: 8-36 VDC.
Max Loop resistance: (Supply voltage – 8 V) / 0.02 for 4-20 mA output.
Power Consumption: $V_{out} = 13$ mA max, $I_{out} = 24$ mA max.
Electrical Connections: Form A DIN 43650.
Process Connections: Standard: 1/4" female NPT, 1/4" female BSPT. With 3-way valve option: 1/8" female NPT, 1/8" female BSPT.
Weight: 1 lb 4 oz (567 g).
Approvals: CE, RCM.

MODEL CHART

Example	629HLP	-01	-P2	-S1	-FC	629HLP-01-P2-S1-FC
Series	629HLP					Differential pressure transmitter
Range		01				0 to 1 bar
		02				0 to 2.5 bar
		04				0 to 4 bar
		06				0 to 6 bar
		15				0 to 15 psi
		30				0 to 30 psi
		60				0 to 60 psi
		90				0 to 90 psi
Process Connections			P2			1/4" female NPT
			P4			1/4" female BPST
Output Signal				S1		4-20 mA
				S5		0-10 VDC
Options					FC	Factory calibration
					NIST	NIST certificate
					3V	3-way valve
Note: Psi ranges available upon request. Contact factory for details.						

PRESSURE RANGE LIMITS

Pressure Range	Maximum Static Pressure (bars)	*Maximum Differential Over Pressure	**Burst Differential Pressure
0 to 1 bar	25 bar	5 bar	8 bar
0 to 2.5 bar	25 bar	5 bar	8 bar
0 to 4 bar	25 bar	12 bar	18 bar
0 to 6 bar	25 bar	12 bar	18 bar
0 to 15 psi	360 psi	70 psi	115 psi
0 to 30 psi	360 psi	70 psi	115 psi
0 to 60 psi	360 psi	174 psi	260 psi
0 to 90 psi	360 psi	174 psi	260 psi
Note: *The differential pressure limit, between high and low ports, that the transmitter can withstand without affecting transmitter performance **Differential pressures between high and low ports that exceed overpressure limits will result in permanent diaphragm deformation, and any pressure higher than the burst pressure limits will rupture the diaphragm.			

ACCESSORIES

Model	Description
A-629HLP-BKT	Mounting bracket kit
BBV-1B	3-Valve block manifold
A-228	12" SS flex hose

USA: California Proposition 65
⚠ WARNING: Cancer and Reproductive Harm - www.P65Warnings.ca.gov

WET/WET DIFFERENTIAL PRESSURE TRANSMITTERS

0.5% Accuracy, NEMA 4X (IP66) Enclosure

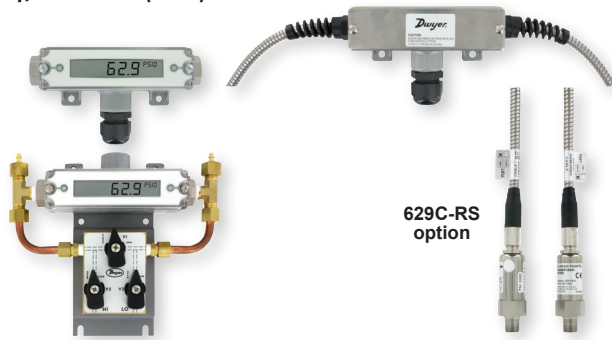

Conduit housing with remote sensor available in 10' or 20' shielded or armored cable

629C-RS option

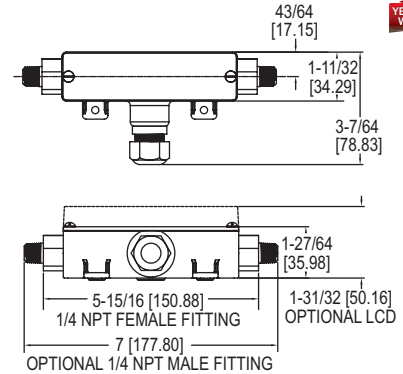

The Series 629C Wet/Wet Differential Pressure Transmitters monitor differential pressure of air and compatible gases and liquids with 0.5% accuracy. The design employs dual pressure sensors converting pressure changes into a standard 4-20 mA output signal or field selectable voltage. Small internal volume and minimal moving parts result in exceptional response and reliability. The terminal block, as well as a zero adjustment button, are easily accessed under the top cover. The Series 629C Differential Pressure Transmitter is designed to meet NEMA 4X (IP66) construction.

FEATURES/BENEFITS

- Powered by either DC or AC - take advantage of most readily available power source reducing installation costs
- Optional LCD does not need a separate power supply - lowers installed cost
- Selectable voltage range - provides flexible choice for changing design or inputs for process/HVAC controllers being used to monitor and control
- Push-button zero (versus trim pot) - more simple zeroing provides easy install and calibration reducing installation time and possibility of operator error
- Optional LCD indicator provides local status to identify operational condition
- Remote sensor option reduces installation labor and material

APPLICATIONS

- Flow elements
- Heat exchangers
- Filters
- Coils
- Chiller
- Pumps

SPECIFICATIONS

Service: Compatible gases and liquids.
Wetted Materials: Without valve: 316, 316L SS. Additional wetted parts with valve option: Buna-N, silicone grease, PTFE, brass 360, copper, and reinforced copolymer.
Accuracy: ±0.5% FS (includes linearity, hysteresis & repeatability).
Stability: ±1% FS/year.
Temperature Limits: 0 to 200°F (-18 to 93°C).
Compensated Temperature Limits: 0 to 175°F (-18 to 79°C).
Pressure Limits: See Table 1.
Thermal Effects: Avg 0.04%/°F (0.072%/°C) (includes zero and span).
Power Requirements: 2-wire: 10-35 VDC; 3-wire: 13-35 VDC or isolated 16-33 VAC (reverse polarity protected).
Output Signal: 2-wire: 4-20 mA; 3-wire: Field selectable 0-5, 1-5, 0-10, or 2-10 VDC.
Zero and Units: Push-buttons inside conduit enclosure.
Response Time: 400 msec.
Loop Resistance: Current output: 0 to 1250 Ω (max), Rmax = 50(Vps-10); Voltage output: Minimum load resistance = 5 kΩ.
Current Consumption: 28 mA (max).
Electrical Connections: Removable terminal block; 1/2" female NPT conduit.
Process Connections: 1/4" female or male NPT.
Display: Optional 4-1/2 digit LCD field attachable display.
Enclosure Rating: Designed to meet NEMA 4X.
Mounting Orientation: Not position sensitive.
Weight: 629C-XX-CH: 10.1 oz (286 g); 629C-XX-R2-P1-E5-XX: 2.3 lbs (1.04 kg); 629C-XX-R6-P1-E5-XX: 4.55 lbs (2.06 kg).
Agency Approvals: CE.

MODEL CHART								
Example	629C	-01	-CH	-P1	-E1	-S1	-3V	629C-01-CH-P1-E1-S1-3V
Series	629C							Wet/wet differential pressure transmitter
Range		01						0 to 5 psid
		02						0 to 10 psid
		03						0 to 25 psid
		04						0 to 50 psid
		05						0 to 100 psid
		06						0 to 150 psid
		07						0 to 200 psid
		08						0 to 300 psid
		09						0 to 500 psid
		11						0 to 0.5 bar differential
		12						0 to 1 bar differential
		13						0 to 2 bar differential
		14						0 to 4 bar differential
		15						0 to 6 bar differential
		16						0 to 10 bar differential
		17						0 to 15 bar differential
		18						0 to 20 bar differential
		19						0 to 30 bar differential
Housing			CH					Conduit housing, NEMA 4X (IP66)
			R1					Conduit housing, NEMA 4X (IP66) with Remote Sensor and 10' shielded cable
			R2					Conduit housing, NEMA 4X (IP66) with Remote Sensor and 20' shielded cable
			R5					Conduit housing, NEMA 4X (IP66) with Remote Sensor and 10' armored cable
			R6					Conduit housing, NEMA 4X (IP66) with Remote Sensor and 20' armored cable
Process Connection				P1				1/4" male NPT
				P2				1/4" female NPT
				P3				1/4" male BSPT
				P4				1/4" female BSPT
Electrical Connection					E1			Cable gland with 3' of prewired cable
					E2			Cable gland with 6' of prewired cable
					E3			Cable gland with 9' of prewired cable
					E5			1/2" female NPT conduit
					E9			M-12 4 pin connector
Signal Output						S1		4-20 mA
						S3		Field selectable 0-5, 1-5, 0-10, 2-10 VDC
Options							3V	3-way valve
							AT	Aluminum tag
							FC	Factory calibration certificate
							LCD	LCD indication
							NIST	NIST traceable certificate

Note: -3V option is only available with -P2 process connection.

RANGE			
Range Number	Range	Working Pressure*	Over Pressure
01	0 to 5 psid	10 psi	50 psi
02	0 to 10 psid	20 psi	50 psi
03	0 to 25 psid	50 psi	120 psi
04	0 to 50 psid	100 psi	250 psi
05	0 to 100 psid	200 psi	500 psi
06	0 to 150 psid	300 psi	750 psi
07	0 to 200 psid	400 psi	1000 psi
08	0 to 300 psid	600 psi	1200 psi
09	0 to 500 psid	1000 psi	2000 psi
11	0 to 0.5 bar differential	1 bar	3 bar
12	0 to 1 bar differential	2 bar	8 bar
13	0 to 2 bar differential	4 bar	8 bar
14	0 to 4 bar differential	8 bar	18 bar
15	0 to 6 bar differential	12 bar	18 bar
16	0 to 10 bar differential	20 bar	50 bar
17	0 to 15 bar differential	30 bar	60 bar
18	0 to 20 bar differential	40 bar	80 bar
19	0 to 30 bar differential	60 bar	120 bar

*Pressures exceeding the working pressure limit may cause a calibration shift of up to ±3% of full-scale.

Note: Over pressure of all models with 3-way valve is 100 psi.

ACCESSORIES	
Model	Description
A-155	Cable gland with 1/2" NPT male
A-228	12" SS flex hose
A-62X-LCD	Field-upgradeable LCD
BBV-1B	Mini SS 3-valve block manifold

USA: California Proposition 65
 ⚠ WARNING: Cancer and Reproductive Harm
 www.P65Warnings.ca.gov

SMART DIFFERENTIAL PRESSURE TRANSMITTER

HART® Communication, Push Button Configuration, Rangeability (Up to 25:1)

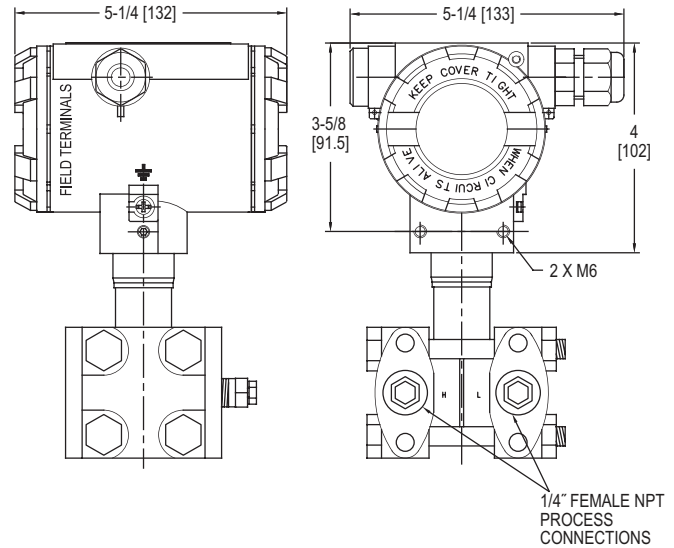

The Series 3500 Smart Differential Pressure Transmitter is a microprocessor-based high performance transmitter, which has flexible pressure calibration, push button configuration, and is programmable using HART® Communication. The Series 3500 is capable of being configured for differential pressure or level applications with the zero and span buttons. A field calibrator is not required for configuration. The transmitter software compensates for thermal effects, improving performance. EEPROM stores configuration settings and stores sensor correction coefficients in the event of shutdowns or power loss. The Series 3500 can be configured to be ATEX or IECEx approved for use in hazardous (classified) locations. The rangeability allows the smart transmitter to be configured to fit any application.

FEATURES/BENEFITS

- High accuracy ($\pm 0.075\%$ FS)
- Rangeability (up to 25:1)
- Configurable using zero/span buttons (no calibrator required)
- Fail-mode process function
- Automatic ambient temperature compensation

APPLICATIONS

- Flow measurement
- Level monitoring
- Filter or pump differential pressure
- Critical process monitoring

MODEL CHART	
Model	Range
3500-AL-02-NF-2	-10 to 10 in w.c.
3500-AL-04-NF-2	0 to 30 in w.c.
3500-AL-08-NF-2	0 to 100 in w.c.
3500-AL-10-NF-2	-200 to 200 in w.c.
3500-AL-15-NF-2	0 to 1000 in w.c.
3500-AL-20-NF-2	0 to 15 psi
3500-AL-25-NF-2	0 to 100 psi
Note: Bar ranges are also available.	

SPECIFICATIONS

Service: Compatible gases, steam, liquids or vapors.
Wetted Materials: 316L SS and FPM; with diaphragm seal: 316L SS.
Accuracy: $\pm 0.075\%$ FS (@ 20°C).
Rangeability: Up to 25:1 turn down.
Stability: $\leq 0.075\%$ FSO/3 years.
Temperature Limits: Ambient: -40 to 185°F (-40 to 85°C); Process with -DS: -40 to 400°F (-40 to 204°C).
Thermal Effect: $< \pm 0.05\%$ span/10°C.
Power Requirements: 10-55 VDC.
Output Signal: 4-20 mA.
Response Time: 16 to 480 ms (programmable).
Damping Time: 0 to 60 seconds.
Electrical Connection: Packing gland M20x1.5, two 1/2" female NPT conduit, screw terminal.
Process Connections: 1/4" female NPT.
Enclosure Rating: NEMA 4X IP66/IP67.
Agency Approvals: CE; -IS, -FP suffix: ATEX Compliant CE 0518 II 2G Ex ia/db IIC T6/T5 Gb Ta<80°C, T5 / II 2D Ex ia/tb IIIC T85°C/T100°C Db. Type Certificate No. KDB 17ATEX0056X. ATEX Standards: EN 60079-0:2012+A11:2013, EN 60079-1:2014, EN 60079-11:2012, EN 60079-26:2015, EN 60079-31:2014 IECEx Compliant: Ex ia/db IIC T6/T5 Gb / Ex ia/tb IIIC T85°C/T100° Db. Certificate of Conformity IECEx KDB 17.0008X. IECEx Standards: IEC 60079-0:2011, IEC 60079-1:2014-06, IEC 60079-11:2011, IEC 60079-26:2006, IEC 60079-31:2013.

SMART DIFFERENTIAL PRESSURE TRANSMITTER

HART® Communication, Push-Button Configuration, Rangeability (Up to 25:1)

MODEL CHART												
Example	3500	-AL	-01	-DS	-1	-SPRB	A	0	-1	-1	-NIST	3500-AL-01-DS-1-SPRBA0-1-1-NIST
Series	3500											Smart differential pressure smart transmitter
Housing		AL AS										Aluminum housing Stainless steel housing
Range			02 04 08 10 15 20 25 38 40 50 60									-10 to 10 in w.c. 0 to 30 in w.c. 0 to 100 in w.c. -200 to 200 in w.c. 0 to 1000 in w.c. 0 to 15 psi 0 to 100 psi 0 to 230 psi 0 to 1000 psi -2.5 to 2.5 in w.c. -1.5 to 1.5 psi
Process Connections				NF DS								1/4" female NPT adapter Diaphragm seal selection
Electrical Connections					1 2							Packing gland M20x1.5 Thread 1/2" female NPT
Diaphragm Seal Type						SPDH SPRB SPRH STDH STRB STRH						S-P flush diaphragm seal direct mount high side S-PK flush diaphragm seal capillary type both sides S-PK flush diaphragm seal capillary type high side S-T extended diaphragm seal direct mount high side S-TK extended diaphragm seal capillary type both sides S-TK extended diaphragm seal capillary type high side
Mounting Flange							A B C D					2" ANSI 2" DN50 3" ANSI 3" DN80
Extension Length								0 2 4 6				No extension, flush mount 2" (50 mm) 4" (100 mm) 6" (150 mm)
Capillary Length High Side									#			High side capillary length, 1 to 20 ft (increments of 1)
Capillary Length Low Side										#		Low side capillary length, 1 to 20 ft (increments of 1)
Options											FP IS MT NIST GB SB ST	ATEX/IECEX flameproof ATEX/IECEX intrinsically safe Stainless steel tag plate mounted on wire NIST traceable calibration certificate 2" galvanized steel mounting bracket 2" SS mounting bracket Stainless steel plate riveted to the housing

ACCESSORIES	
Model	Description
A-630	Stainless steel angle type bracket with SS bolts
A-631	Stainless steel flat type bracket with SS bolts
BBV-0N	2-valve block manifold
DevCom2000	HART® communication protocol software

INDUSTRIAL PRESSURE TRANSMITTERS

Complete Offering of Ranges, Connections and Outputs



626/628 pressure transmitters
with general purpose housing (-GH)



626/628 pressure transmitters
with conduit box housing (-CB) and LCD display



*Please see our website for dimensional drawings.

The **Series 626 Industrial Pressure Transmitters** possess a highly precise 0.25% full-scale accuracy piezo-resistive sensor contained in a compact, rugged, NEMA 4X (IP66) stainless steel general purpose housing or cast aluminum conduit housing. The **Series 628 Industrial Pressure Transmitters** are ideal for OEMs with 1% full-scale accuracy sensors. The corrosion resistant 316L stainless steel wetted parts allow the Series 626 and 628 transmitters to measure the pressure in a multitude of processes from hydraulic oils to chemicals. The Series 626 and 628 are available in absolute and gage pressure ranges with a variety of optional outputs, process connections and electrical terminations to allow you to select the right transmitter for your application.

FEATURES/BENEFITS

- NEMA 4X rated enclosure provides protection in harsh environments permitting outdoor monitoring or in areas where dust and particulate matter exists
- Robust 316 SS oil filled sensor provides shock and vibration resistance insuring stability in controlling pressure for process applications
- A wide range of models and connections that can meet pressure measurement specifications from low to very high

APPLICATIONS

- Compressors
- Pumping systems
- Irrigation equipment
- Hydraulic
- Industrial process monitoring

SPECIFICATIONS

Service: Compatible gases and liquids.

Wetted Materials: Type 316L SS.

Accuracy: 626: 0.25% FS; 626: 0.20% RSS; 628: 1.0% FS; 628: 0.5% RSS; 626 Absolute Ranges: 0.5% FS; 626 absolute ranges: 0.30% RSS. (Includes linearity, hysteresis, and repeatability.)

Temperature Limit: 0 to 200°F (-18 to 93°C).

Compensated Temperature Range: 0 to 175°F (-18 to 79°C).

Thermal Effect: ±0.02% FS/°F (includes zero and span).

Pressure Limits: See table.

Power Requirements: 10-30 VDC (for 4-20 mA, 0-5, 1-5, 1-6 VDC outputs); 13-30 VDC (for 0-10, 2-10 VDC outputs); 5 VDC ±0.5 VDC (for 0.5-4.5 VDC ratio-metric output), 10-35 VDC (for 4-20 mA with -CB option); 13-35 VDC or isolated 16-33 VAC (for selectable output with -CB option).

Output Signal: 4-20 mA, 0-5 VDC, 1-5 VDC, 0-10 VDC, or 0.5-4.5 VDC, or selectable 0-5, 1-5, 0-10, 2-10 VDC for -CB option.

Response Time: 300 ms.

Loop Resistance: 0 to 1000 Ω max. R max = 50 (Vps-10) Ω (4-20 mA output), 0-1250 Ω max. Rmax = 50(Vps-10) Ω (4-20 mA output with -CB option), 5K Ω (0-5, 1-5, 1-6, 0-10, 2-10, 0.5-4.5 VDC output).

Stability: 1.0% FS/year (Typ.).

Current Consumption: 38 mA maximum (for 4-20 mA output); 10 mA maximum (for 0-5, 1-5, 1-6, 0-10, 2-10, 0.5-4.5 VDC output); 140 mA maximum (for all 626/628/629-CH with optional LED).

Electrical Connections: See model chart.

Process Connection: See model chart.

Enclosure Rating: NEMA 4X (IP66).

Mounting Orientation: Mount in any position.

Weight: 10 oz (283 g).

Agency Approvals: CE, NSF, UL.

INDUSTRIAL PRESSURE TRANSMITTERS

Complete Offering of Ranges, Connections and Outputs

MODEL CHART								
Example	626	-00	-CH	-P1	-E1	-S1	-AT	626-00-CH-P1-E1-S1-AT
Accuracy	626 628							0.25% full-scale accuracy 1.0% full-scale accuracy
Range		00 01 02 03 04 05 06 07 08 09 10 11 12 13 14 22 15 16 18 19 26 67 71 75 81						0 to 15 psia [Ⓞ] 0 to 30 psia [Ⓞ] 0 to 50 psia [Ⓞ] 0 to 100 psia [Ⓞ] 0 to 200 psia [Ⓞ] 0 to 300 psia [Ⓞ] 0 to 5 psi 0 to 15 psi 0 to 30 psi 0 to 50 psi 0 to 100 psi 0 to 150 psi 0 to 200 psi [Ⓞ] 0 to 300 psi [Ⓞ] 0 to 500 psi [Ⓞ] 0 to 600 psi [Ⓞ] 0 to 1000 psi 0 to 1500 psi [Ⓞ] 0 to 3000 psi 0 to 5000 psi 0 to 8000 psi 0 to 0.5 bar 0 to 2.5 bar 0 to 10 bar 0 to 40 bar
Housing			CB GH					Conduit box housing General purpose housing
Process Connection				P1 P2 P3 P5 P9				1/4" male NPT 1/4" female NPT 1/4" male BSPT 1/4" female SAE with refrigerant valve depressor [Ⓛ] 1/2" male NPT [Ⓞ]
Electrical Connection					E1 E3 E4 E5 E6 E8 E9			Cable gland with 3' of prewired cable Cable gland with 9' of prewired cable DIN EN 175801-803-C [Ⓞ] 1/2" female NPT conduit [Ⓞ] M-12 4 pin connector-UL [Ⓞ] Packard connector M-12 4 pin connector non-UL
Signal Output						S1 S2 S4 S5 S7 S8		4-20 mA 1-5 VDC 0-5 VDC 0-10 VDC 0.5-4.5 VDC [Ⓛ] [Ⓞ] Selectable 0-5, 1-5, 0-10, 2-10 VDC [Ⓞ]
Options							AT LCD NIST NW	Aluminum tag LCD indication [Ⓞ] NIST traceable certificate NSF/ANSI 61/372 certified
[Ⓛ] Available with -GH housing only, NEMA 4 (IP65) [Ⓞ] Available with -CB housing only [Ⓞ] Power requirement: 5 VDC ±10% [Ⓞ] Available with -GH housing only [Ⓞ] Absolute ranges for 626 are 0.5% FS accuracy and for 628 are 2% FS accuracy [Ⓞ] UL listed pump controllers, fire-component - See online certificate for information and limitations								
Note: Bar and absolute ranges are only available with -GH housing.								

PRESSURE LIMITS							
Range Number	Pressure Range	Maximum Pressure (psig)	Over Pressure (psig)	Range Number	Pressure Range (psig)	Maximum Pressure (psig)	Over Pressure (psig)
00	0 to 15 psia	30	45	12	0 to 200	400	1000
30	15 to 0 psia	30	45	13	0 to 300	600	1500
06	0 to 5 psig	10	50	14	0 to 500	1000	2500
07	0 to 15 psig	30	150	15	0 to 1000	2000	5000
08	0 to 30 psig	60	300	16	0 to 1500	3000	5000
09	0 to 50 psig	100	300	18	0 to 3000	6000	7500
10	0 to 100 psig	200	500	19	0 to 5000	7500	10000
11	0 to 150 psig	300	750	26	0 to 8000	10000	12000

ACCESSORIES	
Model	Description
A-164	16.4' (5 m) cable with M-12 4-pin female connector
A-62X-LCD	Field-upgradeable LCD
A-960	3' packard cable
A-961	9' packard cable
A-962	20' packard cable



SERIES TE-E/N

WALL MOUNT TEMPERATURE SENSORS

Discrete Wall Mount Housing



European

North American

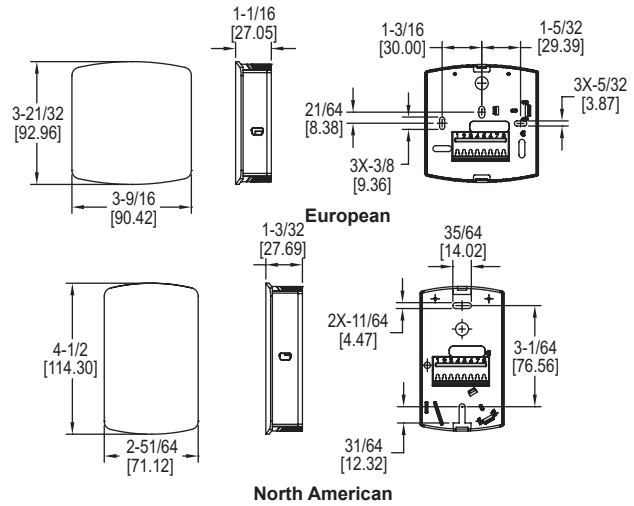

The Series TE-E/N Wall Mount Temperature Sensors provide a low cost temperature input for any building management system.

FEATURES/BENEFITS

- North American or European housing aesthetic options
- Uniform look matches other Dwyer wall mount devices
- Universal mounting plate meets various installation requirements

APPLICATIONS

- Building automation
- Room temperature monitoring

SPECIFICATIONS

Accuracy: Thermistor temp sensor: $\pm 0.22^{\circ}\text{C}$ @ 25°C ($\pm 0.4^{\circ}\text{F}$ @ 77°F); RTD temp sensor: DIN class B; $\pm 0.3^{\circ}\text{C}$ @ 0°C ($\pm 54^{\circ}\text{F}$ @ 32°F).
Temperature Limits: -40 to 140°F (-40 to 60°C).
Housing Material: ABS plastic.
Weight: 0.3 lb (136 g).

MODEL CHART

North American Model	Sensor Type	European Model	Sensor Type
TE-NND-A	10k Ω type III thermistor	TE-END-A	10k Ω type III thermistor
TE-NND-B	10k Ω type II thermistor	TE-END-B	10k Ω type II thermistor
TE-NND-C	3k Ω thermistor	TE-END-C	3k Ω thermistor
TE-NND-D	Pt100 Ω RTD	TE-END-D	Pt100 Ω RTD
TE-NND-E	Pt1000 Ω RTD	TE-END-E	Pt1000 Ω RTD
TE-NND-F	20k Ω thermistor	TE-END-F	20k Ω thermistor
TE-NND-Q	10k Ω type III with 11 k Ω shunt		

SERIES TE-WSS

STAINLESS STEEL WALL PLATE TEMPERATURE SENSOR

Screw Terminal Connection, Suitable for Wash Down Applications

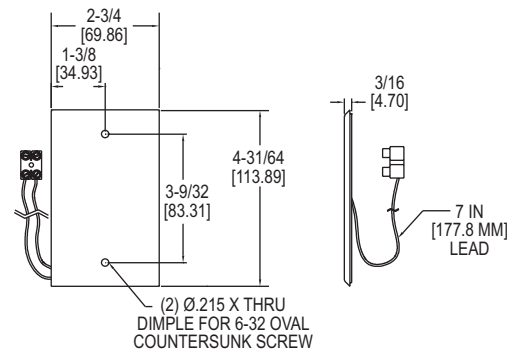

The Series TE-WSS Stainless Steel Wall Plate Temperature Sensor measures the ambient air temperature in classrooms and industrial environments.

FEATURES/BENEFITS

- SS flush plate design
- Standard single gang junction box cover plate mounting

APPLICATIONS

- Building automation
- Room temperature monitoring
- Wash down environments

SPECIFICATIONS

Accuracy: Thermistor: $\pm 0.22^{\circ}\text{C}$ @ 25°C ($\pm 0.4^{\circ}\text{F}$ @ 77°F); RTD: DIN Class B $\pm 0.3^{\circ}\text{C}$ @ 0°C .
Temperature Limits: Operating -40 to 140°F (-40 to 60°C).
Sensor Curves: See page reference 1 below.
Housing Material: 304 SS wall plate.
Weight: 2.3 oz (65 g).

MODEL CHART

Model	Sensor Type
TE-WSS-A	10k Ω type III thermistor
TE-WSS-B	10k Ω type II thermistor
TE-WSS-C	3k Ω thermistor
TE-WSS-D	PT100 Ω RTD
TE-WSS-E	PT1000 Ω RTD
TE-WSS-F	20k Ω thermistor

1 Resistance vs. Temperature Table: See page 32 (Series TE-OND/RND/OSA)

DUCT AND IMMERSION BUILDING AUTOMATION TEMPERATURE SENSORS

Available up to 18" Probe Length, Thermistor or RTD Outputs

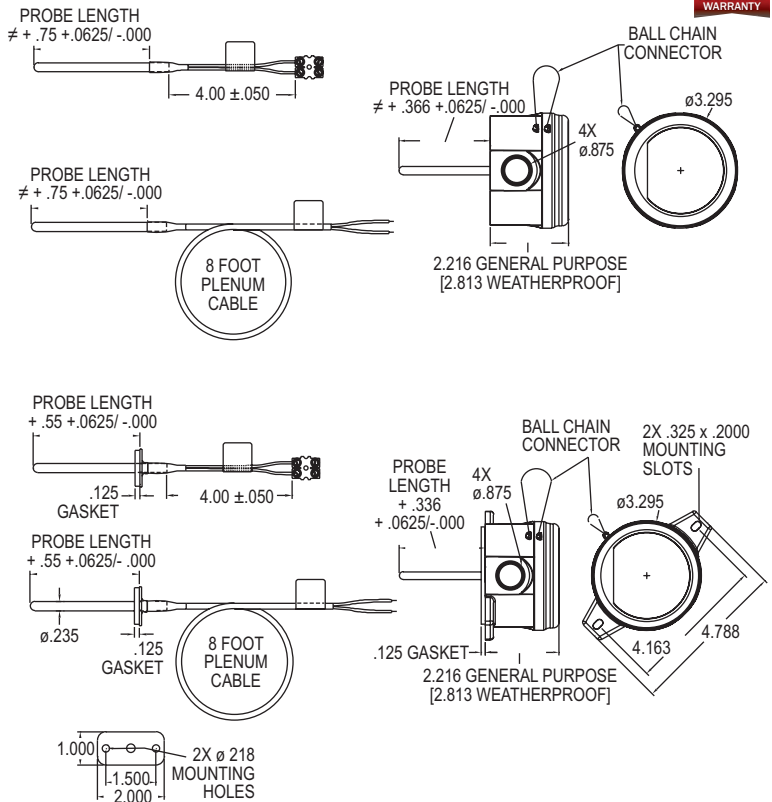
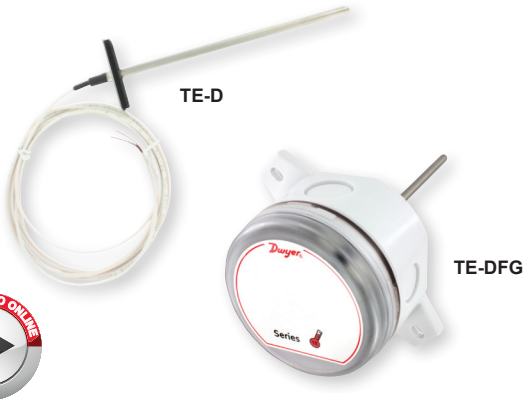

The Series TE Duct and Immersion Building Automation Temperature Sensors can be used to monitor air or water temperature throughout a building management system or an air handler unit. Duct or immersion options available with or without an enclosure.

FEATURES/BENEFITS

- Easy to mount external tab housing and flange options for duct applications
- 1/4 turn housing cover with chain to prevent dropping
- Multiple conduit knockouts for easy installation positioning
- 8' plenum rated cable option
- Terminal connector eliminates need for wire nuts

APPLICATIONS

- Building automation
- VAV temperature sensing
- Chiller or boiler loops
- AHU monitoring

SPECIFICATIONS

Accuracy: Thermistor temperature sensor: $\pm 0.22^\circ\text{C}$ @ 25°C ($\pm 0.4^\circ\text{F}$ @ 77°F); RTD temperature sensor: DIN class A: $\pm 0.15^\circ\text{C}$ @ 0°C ($\pm 0.28^\circ\text{F}$ @ 32°F).
Temperature Limits: Operating: -40 to 302°F (-40 to 150°C).
Sensor Curves: See page reference 1 below.
Cable Rating: Plenum option includes UL listed plenum cable.
Housing Material: Meets UL, 94 V-0 polycarbonate plastic.
Housing Rating: NEMA 4X (IP66) (DFW, IBW only).
Weight: 5.3 oz (150.3 g).
Agency Approvals: Meets the technical requirements of EU Directive 2011/65/EU (RoHS II).

MODEL CHART

Example	TE	-DFN	-A	04	4	8	-00	TE-DFN-A0448-00
Series	TE							Temperature sensor
Mounting Configuration		DFN DFG DFW IBN IBG IBW						Duct mount probe only Duct mount probe in general purpose housing Duct mount probe in NEMA 4X housing Immersion probe only Immersion probe in general purpose housing Immersion probe in NEMA 4X housing
Sensor Type			A B C D E F Q					10k Ω type III thermistor 10k Ω type II thermistor 3k Ω thermistor Pt100 Ω RTD Pt1000 Ω RTD 20k Ω thermistor 10k Ω type III with 11k Ω shunt
Probe Length				25 04 06 08 12 18				2.5" 4" 6" 8" 12" 18" (DFN/DFG only)
Probe Diameter					4 5			1/4" 1/4" double encapsulated
Termination						3 4 7 8		4" leads with spade connectors 4" leads 8" plenum rated cable with spade connectors 8" plenum rated cable
Fittings							00 12 14	None (probe only) 1/2" NPT compression fitting 1/4" NPT compression fitting

●Resistance vs. Temperature Table: See page 32 (Series TE-OND/RND/OSA)



SERIES TE-I

IMMERSION TEMPERATURE SENSORS

Integral Mounting Connection, Welded Thermowells

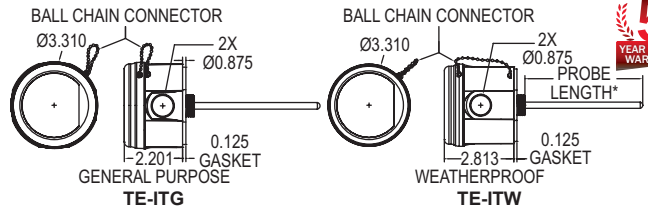

The Series TE-I Immersion Style Temperature Sensors accurately measure water temperature inside chilled and hot water loops in HVAC systems. Thermowells are required to protect the electrical connection from the process water and to allow replacement of the sensors without draining the system.

FEATURES/BENEFITS

- Integral 1/2" NPSM connection for direct mounting to a thermowell
- 1/4 turn housing cover with chain to prevent dropping
- Multiple conduit knockouts for easy installation positioning
- General purpose or weatherproof enclosure options
- Terminal connection eliminates need for wire nuts

APPLICATIONS

- Chiller or boiler loops
- Building automation

SPECIFICATIONS

Accuracy: Thermistor temperature sensor: $\pm 0.22^{\circ}\text{C}$ @ 25°C ($\pm 0.4^{\circ}\text{F}$ @ 77°F); RTD temperature sensor DIN Class A: $\pm 0.15^{\circ}\text{C}$ @ 0°C ($\pm 0.28^{\circ}\text{F}$ @ 32°F).
Temperature Limits: Operating: -40 to 302°F (-40 to 150°C).
Sensor Curves: See page reference below.
Housing Material: Meets UL, 94 V-0 polycarbonate plastic.
Thermowell Material: 304 SS.
Thermowell Connections: Internal = 1/2" NPSM; External = 1/2" NPT.
Weight: 5.3 oz (150.3 g).

MODEL CHART

Example	TE	-ITG	-A	25	4	4	-00	TE-ITG-A2544-00
Series	TE							Duct and immersion building automation temperature sensor
Mounting Configuration		ITG ITW						Immersion in general purpose housing Immersion in NEMA 4X housing
Sensor Type			A B C D E F Q					10k Ω type III thermistor 10k Ω type II thermistor 3k Ω thermistor Pt100 Ω RTD Pt1000 Ω RTD 20k Ω thermistor 10k Ω type III with 11k Ω shunt
Probe Length*				25 04 06 08 12 18				2.5" 4" 6" 8" 12" 18"
Probe Diameter					4 5			1/4" 1/4" double encapsulated
Termination						4		4" flying leads terminal block
Fittings							00	None (integral)

*Resistance vs. Temperature Table: See page 32 (Series TE-OND/RND/OSA)

*Actual probe length is approximately 0.75" longer than listed probe length to ensure maximum immersion into thermowells.

TE-TNS

THERMOWELLS

Thermowells for Building Automation Temperature Sensors

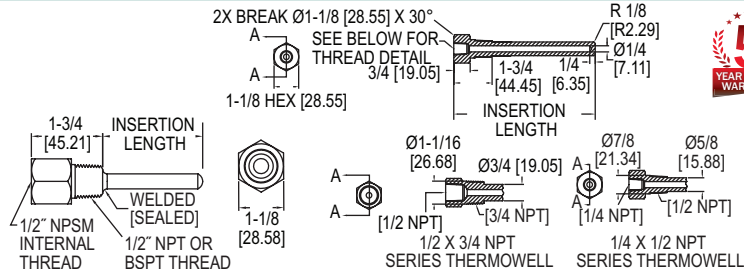
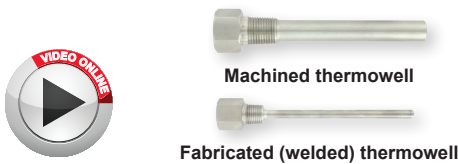

The Series TE-TNS Stainless Steel Thermowells are used to separate the instrument from the surrounding media. When used with the Series TE and TE-I Immersion Temperature Sensors, further protection is offered from aggressive media, high pressures, and flow rates while allowing for quick and easy installation of temperature sensors without having to drain process media. Thermowells are offered in both 304 and 316 stainless steel allowing for superior corrosion resistance. Fabricated, or welded, thermowells are constructed from a tube that is closed at the tip by a welded solid tip. Solid-machined thermowells are manufactured from barstock.

FEATURES/BENEFITS

- Configurable materials and sizes
- Fabricated (welded) or machined construction
- 1/2" or 3/4" NPT process connections

APPLICATIONS

- Building automation
- Chiller or boiler loops
- Chemical industry or process technology

SPECIFICATIONS

Maximum Pressure: Fabricated: 140 psi; Machined: 304 SS: 3700 psi; 316 SS: 5500 psi.
Maximum Temperature: Fabricated: 1000°F (538°C); Machined: 1200°F (648°C).
Construction: Fabricated (welded) or machined model specific.

MODEL CHART

Example	TE-TNS	-N	9	5N	-14	TE-TNS-N095N-14
Series	TE-TNS					Stainless steel thermowell
Thread Type		N				NPT
Length			25 04 06 09 12 18			2.5" 4" 6" 9" 12" 18"
Material & Construction				3N 4N 5N		304 SS fabricated (welded) 304 SS machined 316 SS machined
Connection (Internal & External)					00	1/2" NPSM / 1/2" NPT 12 1/2" NPT / 3/4" NPT 14 1/4" NPT / 1/2" NPT

Model	Material	Length	Construction	Connection (Internal/External)
TE-TNS-N254N-12	304 SS	2.5"	Machined	1/2" NPT / 3/4" NPT
TE-TNS-N254N-14	304 SS	2.5"	Machined	1/4" NPT / 1/2" NPT
TE-TNS-N044N-14	304 SS	4"	Machined	1/4" NPT / 1/2" NPT
TE-TNS-N044N-12	304 SS	4"	Machined	1/2" NPT / 3/4" NPT
TE-TNS-N064N-14	304 SS	6"	Machined	1/4" NPT / 1/2" NPT
TE-TNS-N064N-12	304 SS	6"	Machined	1/2" NPT / 3/4" NPT
TE-TNS-N094N-14	304 SS	9"	Machined	1/4" NPT / 1/2" NPT
TE-TNS-N094N-12	304 SS	9"	Machined	1/2" NPT / 3/4" NPT
TE-TNS-N124N-14	304 SS	12"	Machined	1/4" NPT / 1/2" NPT
TE-TNS-N124N-12	304 SS	12"	Machined	1/2" NPT / 3/4" NPT
TE-TNS-N045N-14	316 SS	4"	Machined	1/4" NPT / 1/2" NPT
TE-TNS-N045N-12	316 SS	4"	Machined	1/2" NPT / 3/4" NPT
TE-TNS-N065N-14	316 SS	6"	Machined	1/4" NPT / 1/2" NPT
TE-TNS-N065N-12	316 SS	6"	Machined	1/2" NPT / 3/4" NPT
TE-TNS-N095N-14	316 SS	9"	Machined	1/4" NPT / 1/2" NPT
TE-TNS-N095N-12	316 SS	9"	Machined	1/2" NPT / 3/4" NPT
TE-TNS-N125N-14	316 SS	12"	Machined	1/4" NPT / 1/2" NPT
TE-TNS-N125N-12	316 SS	12"	Machined	1/2" NPT / 3/4" NPT
TE-TNS-N253N-00	304 SS	2.5"	Fabricated	1/2" NPSM / 1/2" NPT
TE-TNS-N043N-00	304 SS	4"	Fabricated	1/2" NPSM / 1/2" NPT
TE-TNS-N063N-00	304 SS	6"	Fabricated	1/2" NPSM / 1/2" NPT
TE-TNS-N083N-00	304 SS	8"	Fabricated	1/2" NPSM / 1/2" NPT
TE-TNS-N123N-00	304 SS	12"	Fabricated	1/2" NPSM / 1/2" NPT
TE-TNS-N183N-00	304 SS	18"	Fabricated	1/2" NPSM / 1/2" NPT

OUTDOOR TEMPERATURE SENSORS

Protection Against Radiated Heat, Weatherproof Housing

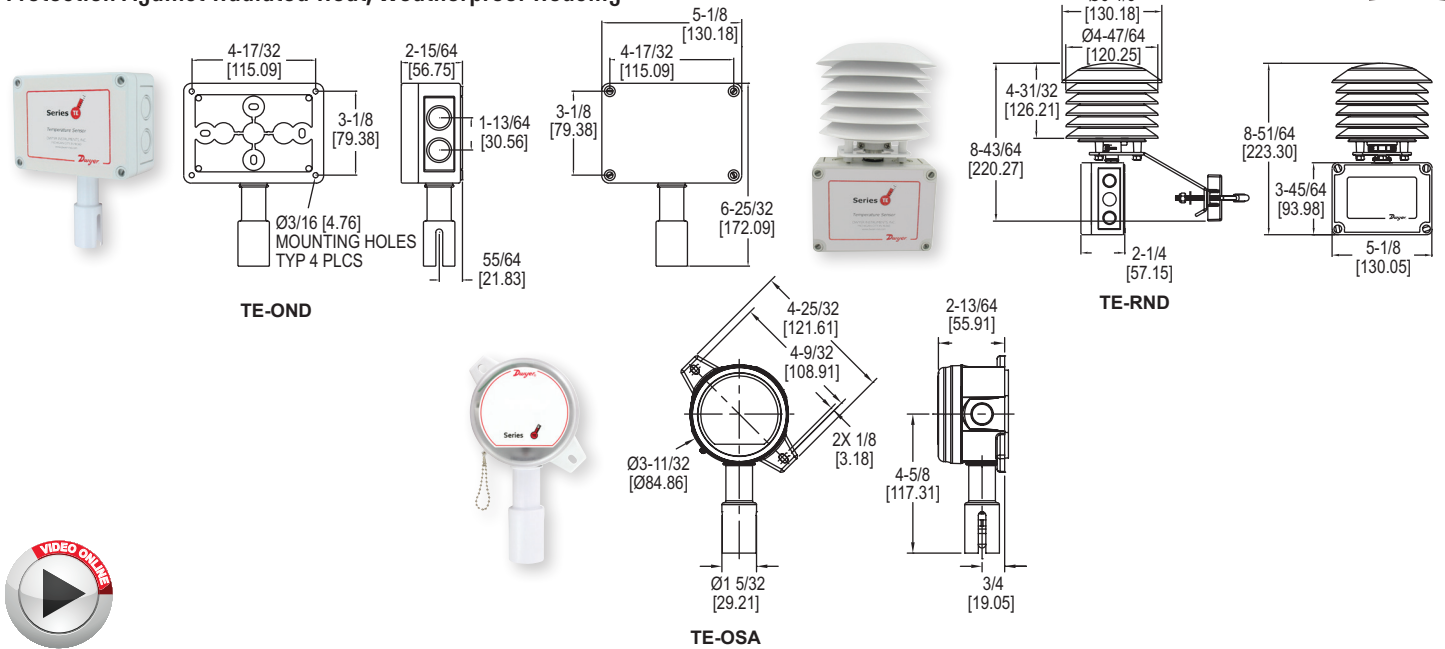

The Series TE-OND/TE-RND/TE-OSA Outdoor Temperature Sensors are offered different configurations to increase measurement accuracy by reducing radiated heat effects. For applications where the north side of the building is accessible, the TE-OND/TE-OSA can be used to protect against low levels of radiated heat.

FEATURES/BENEFITS

- Weatherproof for outdoor installation
- Radiation shield available to eliminate heating effects following installation in direct sunlight
- Terminal connector eliminates need for wire nuts

APPLICATIONS

- Building automation
- Outdoor temperature reference

SPECIFICATIONS

Accuracy: Thermistor temperature sensor: $\pm 0.22^\circ\text{C}$ @ 25°C ($\pm 0.4^\circ\text{F}$ @ 77°F); RTD temperature sensor: DIN class A: $\pm 0.15^\circ\text{C}$ @ 0°C ($\pm 0.28^\circ\text{F}$ @ 32°F).
Temperature Limits: Operating: -40 to 302°F (-40 to 150°C).
Sensor Curves: See Resistance vs. Temperature Table.
Housing Material: Polycarbonate.
Enclosure Rating: TE-OND/TE-RND: NEMA 4X (IP65); TE-OSA: NEMA 3R (IP54).
Weight: 0.65 lb (295 g).

RESISTANCE VS TEMPERATURE TABLE

Temperature Resistance Curves (Ω)

°C	°F	A - 10k Ω type III thermistor	B - 10k Ω type II thermistor	C - 3k Ω thermistor	D - PT100 Ω RTD	E - PT1000 Ω RTD	F - 20k Ω thermistor	Q - 10k Ω type III thermistor with 11k Ω shunt
		Green/Green	Red/Green	Black/Black	Yellow/Yellow	Red/Red	Green/Blue	Red/White
-55	-67.0	607800.00	963849.00	289154.70	78.32	783.2	2394000.00	10804
-50	-58.0	441200.00	670166.00	201049.80	80.31	803.1	1646200.00	10732
-45	-49.0	323600.00	471985.00	141595.50	82.29	822.9	1145800.00	10638
-40	-40.0	239700.00	336479.00	100943.70	84.27	842.7	806800.00	10517
-35	-31.0	179200.00	242681.00	72804.30	86.25	862.5	574400.00	10364
-30	-22.0	135200.00	176974.00	53092.20	88.22	882.2	413400.00	10172
-25	-13.0	102900.00	130421.00	39126.30	90.19	901.9	300400.00	9938
-20	-4.0	78910.00	97081.00	29124.30	92.16	921.6	220600.00	9654
-15	5.0	61020.00	72957.00	21887.10	94.12	941.2	163500.00	9320
-10	14.0	47540.00	55329.00	16598.70	96.09	960.9	122280.00	8933
-5	23.0	37310.00	42327.00	12698.10	98.04	980.4	92240.00	8495
0	32.0	29490.00	32650.00	9795.00	100.00	1000.0	70160.00	8012
5	41.0	23460.00	25392.00	7617.60	101.95	1019.5	53780.00	7489
10	50.0	18780.00	19901.00	5970.30	103.90	1039.0	41560.00	6937
15	59.0	15130.00	15712.00	4713.60	105.85	1058.5	32340.00	6369
20	68.0	12260.00	12493.00	3747.90	107.79	1077.9	25360.00	5798
25	77.0	10000.00	10000.00	3000.00	109.74	1097.4	20000.00	5238
30	86.0	8194.00	8057.00	2417.10	111.67	1116.7	15892.00	4696
35	95.0	6752.00	6531.00	1959.30	113.61	1136.1	12704.00	4184
40	104.0	5592.00	5326.00	1597.80	115.54	1155.4	10216.00	3707
45	113.0	4655.00	4368.00	1310.40	117.47	1174.7	8264.00	3271
50	122.0	3893.00	3602.00	1080.60	119.40	1194.0	6722.00	2875
55	131.0	3271.00	2986.00	895.80	121.32	1213.2	5498.00	2521
60	140.0	2760.00	2488.00	746.40	123.24	1232.4	4520.00	2206
65	149.0	2339.00	2083.00	624.90	125.16	1251.6	3734.00	1929
70	158.0	1990.00	1752.00	525.60	127.08	1270.8	3100.00	1685
75	167.0	1700.00	1480.00	444.00	128.99	1289.9	2586.00	1472
80	176.0	1458.00	1255.00	376.50	130.90	1309.0	2166.00	1287
85	185.0	1255.00	1070.00	321.00	132.80	1328.0	1822.60	1126
90	194.0	1084.00	915.50	274.65	134.71	1347.1	1540.00	986.8
95	203.0	939.30	786.60	235.98	136.61	1366.1	1306.40	865.4
100	212.0	816.80	678.60	203.58	138.51	1385.1	1112.60	760.3
105	221.0	712.60	587.60	176.28	140.40	1404.0	951.00	669.2
110	230.0	623.60	510.60	153.18	142.29	1422.9	815.80	590.1
115	239.0	547.30	445.30	133.59	144.18	1441.8	702.20	521.4
120	248.0	481.80	389.60	116.88	146.07	1460.7	606.40	461.6
125	257.0	425.30	341.90	102.57	147.95	1479.5	525.60	409.5
130	266.0	376.40	301.00	90.30	149.83	1498.3	N/A	363.9
135	275.0	334.00	265.80	79.74	151.71	1517.1	N/A	324.2
140	284.0	297.20	235.30	70.59	153.58	1535.8	N/A	289.4
145	293.0	265.10	208.90	62.67	155.46	1554.6	N/A	258.9
150	302.0	237.00	186.10	55.83	157.33	1573.3	N/A	232.0

Dwyer
SERIES TE-A

AVERAGING TEMPERATURE SENSOR

Available in 6', 12' and 24' Lengths

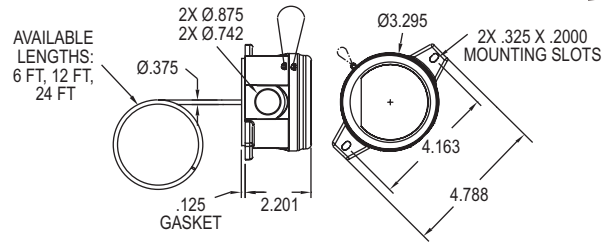
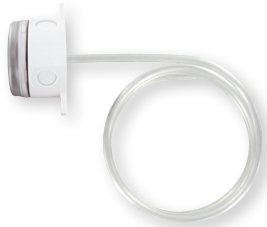

The **Series TE-A Averaging Temperature Sensor** features a long bendable aluminum capillary to measure the average temperature in large ducts and air handler units.

FEATURES/BENEFITS

- Easy to mount external tab housing
- 1/4 turn housing cover with chain
- Multiple conduit knockouts for easy installation positioning

APPLICATIONS

- Building automations
- Air handler unit monitoring
- Large air duct temperature monitoring

SPECIFICATIONS

Accuracy: Thermistor temperature sensor: $\pm 0.22^{\circ}\text{C}$ @ 25°C ($\pm 0.4^{\circ}\text{F}$ @ 77°F).
Temperature Limits: -40 to 302°F (-40 to 150°C).
Capillary Lengths: 6, 12 or 24' (depending on model).
Cable Length: 4".
Sensor Curves: See page reference 1 below.
Probe Material: Bendable aluminum probe.
Housing Material: Meets UL, 94 V-0 polycarbonate plastic.
Weight: 14 oz (397 g).

MODEL CHART

Model	Sensor Type	Capillary Length	Model	Sensor Type	Capillary Length
TE-AAG-A0634-00	10k type III NTC thermistor	6'	TE-AAG-C0634-00	3k NTC thermistor	6'
TE-AAG-A1234-00	10k type III NTC thermistor	12'	TE-AAG-C1234-00	3k NTC thermistor	12'
TE-AAG-A2434-00	10k type III NTC thermistor	24'	TE-AAG-C2434-00	3k NTC thermistor	24'
TE-AAG-B0634-00	10k type II NTC thermistor	6'	TE-AAG-F0634-00	20k NTC thermistor	6'
TE-AAG-B1234-00	10k type II NTC thermistor	12'	TE-AAG-F1234-00	20k NTC thermistor	12'
TE-AAG-B2434-00	10k type II NTC thermistor	24'	TE-AAG-F2434-00	20k NTC thermistor	24'

AVERAGING TEMPERATURE SENSOR CLIPS

Model	Color	Sensor Diameter Size
CC1-N	Natural	3/8", 1/4", or 1/8"
CC1-GY	Grey	3/8", 1/4", or 1/8"

Note: Sold individually

● Resistance vs. Temperature Table: See page 32 (Series TE-OND/RND/OSA)

SERIES O-4

OUTSIDE AIR TEMPERATURE SENSOR

NEMA 4X, Removable Terminal Block

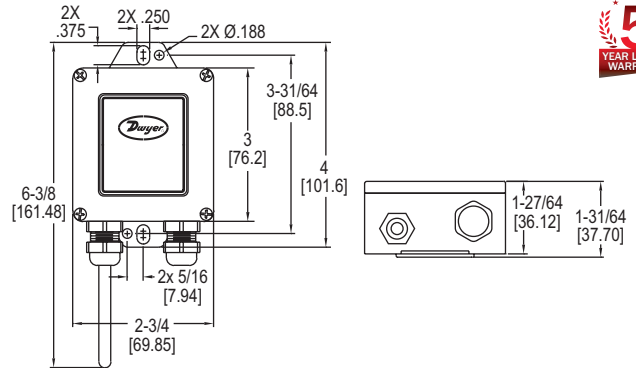

The **Series O-4 Outside Air Temperature Sensor** is great for monitoring ambient air temperatures in outdoor applications. The temperature sensors are mounted in a NEMA 4X enclosure with integral mounting tabs.

FEATURES/BENEFITS

- NEMA 4X weatherproof housing
- Surface or suspension mount

APPLICATIONS

- Agricultural house ventilation
- HVAC and building automation

MODEL CHART

Model	Sensor Type	Model	Sensor Type
O-4A	10k Ω type III thermistor	O-4D	Pt100 Ω RTD
O-4B	10k Ω type II thermistor	O-4E	Pt1000 Ω RTD
O-4C	3k Ω thermistor	O-4F	20k Ω thermistor

SPECIFICATIONS

Accuracy: Thermistor temperature sensor: $\pm 0.22^{\circ}\text{C}$ @ 25°C ($\pm 0.4^{\circ}\text{F}$ @ 77°F); RTD temperature sensor: DIN class B: $\pm 0.3^{\circ}\text{C}$ @ 0°C ($\pm 0.54^{\circ}\text{F}$ @ 32°F).
Operating Temperature: -40 to 250°F .
Probe Diameter: 0.235" (5.97 mm).
Probe Length: 3.5".
Probe Material: 304 SS.
Mounting: Suspension or surface.
Enclosure Rating: NEMA 4X (IP66).
Weight: 3 oz (85 g).
Agency Approvals: Meets the technical requirements of EU Directive 2011/65/EU (RoHS II).

WEATHER RESISTANT SURFACE TEMPERATURE SENSOR

Strap On Design, Twist Off Cover, 2 to 6" Pipe Sizes

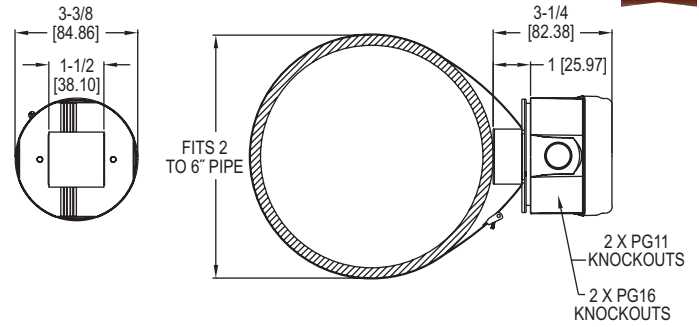

The **Series TE-SNW Weather Resistant Surface Temperature Sensor** non-intrusively measures the process temperature in hot and cold water loops in buildings. In order to work with most common building controllers, the output of the sensor can be chosen from 6 different RTD and Thermistor curves.

FEATURES/BENEFITS

- Easy to mount external tab housing
- 1/4 turn housing cover with chain
- Multiple conduit knockouts for easy installation positioning
- Non-intrusive temperature measurement of 2 to 6" pipes

APPLICATIONS

- Heating or cooling loop line temperature monitoring
- HVAC systems

SPECIFICATIONS

Accuracy: Thermistor temperature sensor: $\pm 0.22^{\circ}\text{C}$ @ 25°C ($\pm 0.4^{\circ}\text{F}$ @ 77°F); RTD temperature sensor: DIN Class A $\pm 0.15^{\circ}\text{C}$ @ 0°C ($\pm 0.28^{\circ}\text{F}$ @ 32°F).
Temperature Limits: Operating: -32 to 240°F (-35.5 to 115.5°C).
Sensor Curves: See page reference 1 below.
Housing Material: Meets UL 94 V-0 polycarbonate plastic, NEMA 3R.
Weight: 7 oz (198 g).

MODEL CHART

Model	Sensor Type
TE-SNW-A	10k Ω type III thermistor
TE-SNW-B	10k Ω type II thermistor
TE-SNW-C	3k Ω thermistor
TE-SNW-D	Pt100 Ω RTD
TE-SNW-E	Pt1000 Ω RTD
TE-SNW-F	20k Ω thermistor

1 Resistance vs. Temperature Table: See page 32 (Series TE-OND/RND/OSA)

SERIES S2-1

SURFACE MOUNT TEMPERATURE SENSOR

RTD and Thermistor, 304 SS Probe

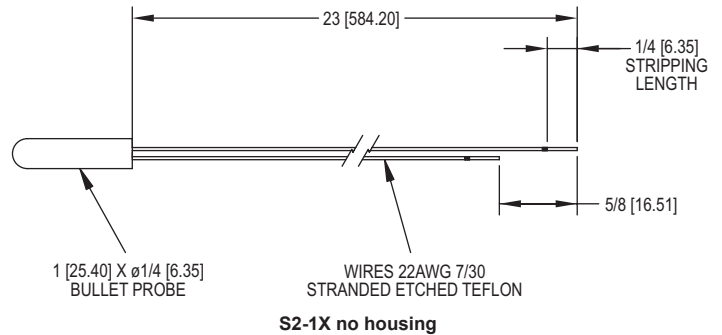

The **Series S2-1 Surface Mount Temperature Sensor** provides a cost effective and reliable solution for surface contact temperature measurement of conditioned water pipes, low pressure steam or refrigerant lines.

FEATURES/BENEFITS

- Low profile sensor can be taped or strapped to the outside of a pipe
- Ideal for applications where immersion wells are not feasible

APPLICATIONS

- Heating or cooling loop line temperature monitoring
- HVAC systems

SPECIFICATIONS

Accuracy: Platinum RTD: $\pm 0.1\%$ @ 32°F (0°C), alpha 385 per DIN 43760; Thermistor: $\pm 0.5^{\circ}\text{C}$ interchangeable @ 77°F (25°C).
Operating Temperature: -40 to 250°F (-40 to 120°C).
Probe Diameter: 1/4" (6.3 mm).
Probe Length: 1" (25 mm).
Probe Material: 304 SS.

MODEL CHART

Model	Sensor Type
S2-1A	10k Type III thermistor
S2-1B	10k Type II thermistor
S2-1C	3k thermistor
S2-1D	Pt100 RTD
S2-1E	Pt1000 RTD
S2-1F	20k thermistor

TEMPERATURE TRANSMITTER

Wall Mount for Building Applications

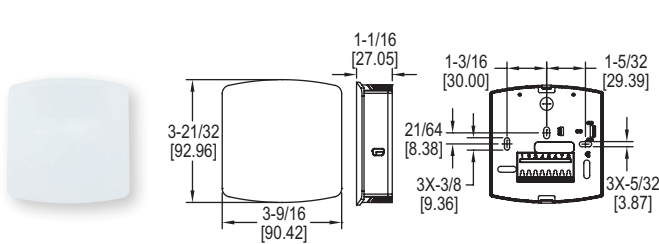

European style

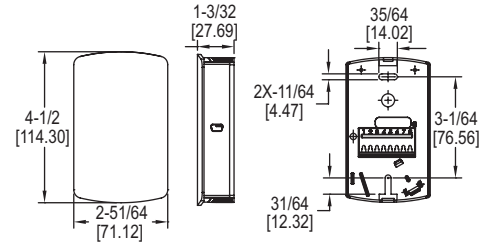

North American style



The Series BTT-E/N Temperature Transmitters offer transmitter output signals with the same form and fit as our popular Series TE-E/N thermistor and RTD sensors for Building Automation and HVAC installations.

FEATURES/BENEFITS

- Transmitter signal offers reliable accuracy for installations with long wire runs between the transmitter and the receiver/controller

APPLICATIONS

- Room or indoor building space temperature monitoring

MODEL CHART		
Model	Housing	Output
BTT-N00-3	North American style	4-20 mA
BTT-N00-4	North American style	0-10 VDC
BTT-E00-3	European style	4-20 mA
BTT-E00-4	European style	0-10 VDC

SPECIFICATIONS

Temperature Sensor: Pt 1000 Ω RTD DIN Class A 0.00385Ω/°C.
Range: 32 to 122 °F (0 to 50 °C).
Temperature Limits: 32 to 122 °F (0 to 50 °C).
Accuracy: ±0.5 °C @ 25 °C.
Thermal Effect: ±0.01%/°C.
Response Time: 100 ms.
Power Requirements: 13-36 VDC for current models, 13-36 VDC or 16-28 VAC for voltage models.
Output Signal: 4-20 mA or 0-10 VDC (depending on model).
Electrical Connections: Screw terminal block.
Enclosure Rating: IP20.
Weight: 2.6 oz (73.7 g).
Agency Approvals: CE.

TEMPERATURE TRANSMITTERS

Current or Voltage Output, NEMA 4X Enclosures

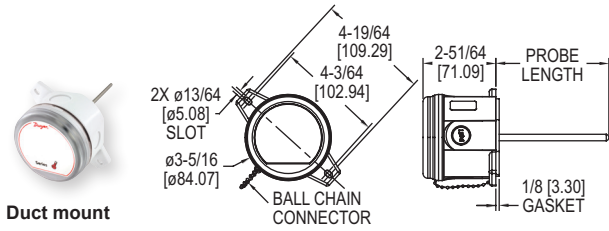

Duct mount

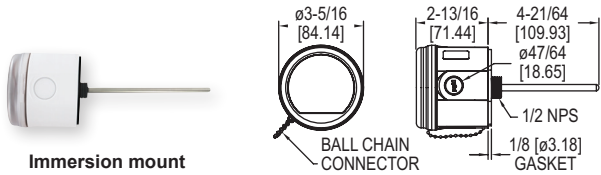

Immersion mount

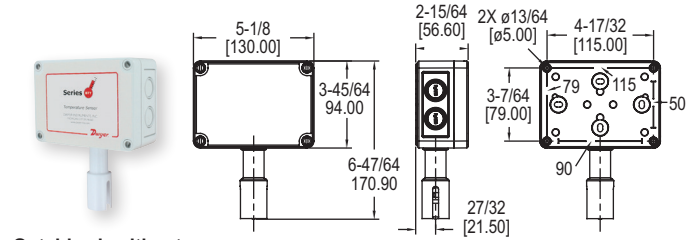

Outside air without radiation shield

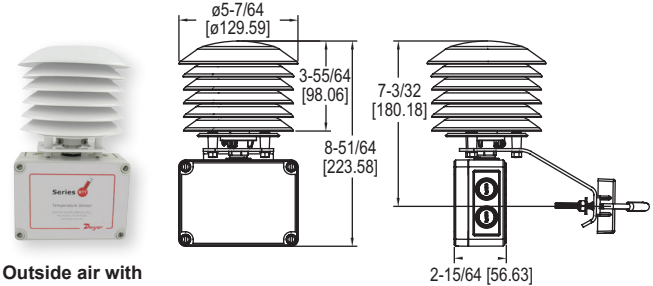

Outside air with radiation shield

The Series BTT Temperature Transmitters offer transmitter output signals with the same form and fit as our popular TE thermistor and RTD sensors for building HVAC applications. Thermowells are required when using immersion models in liquid applications.

FEATURES/BENEFITS

- Duct, immersion, and outside air models available
- Radiation shield available for mounting in direct sunlight
- Transmitter output allows for longer wire runs than standard thermistor sensors

APPLICATIONS

- Building automation system temperature monitoring

SPECIFICATIONS

Temperature Sensor: Pt1000 RTD.
Range: -40 to 140°F (-40 to 60°C).
Temperature Limits: Operating: -40 to 302°F (-40 to 150°C).
Accuracy: ±0.5°C @ 25°C.
Thermal Effect: ±0.01%/°C.
Response Time: 100 ms.
Wetted Materials: All models: 304 SS (probe), polycarbonate (housing); Duct and immersion models: Neoprene (gasket); Outside air models: Nylon (insert), silicone (O-ring).
Process Connection: 1/2" NPS (immersion models only).
Electrical Connection: Removable terminal block, knocks out for conduit fitting.
Conduit Connection: 1/2" NPT.
Probe Lengths: 2.5 to 18" (depending on configuration).
Power Requirements: 13-36 VDC for current models, 13-36 VDC or 16-28 VAC for voltage models.
Output Signal: 4-20 mA or 0-10 VDC (depending on model).
Enclosure Rating: NEMA 4X (IP66) (immersion models require thermowell).
Weight: 5.11 oz (145 g) (duct/immersion); 8.4 oz (238 g) (OSA without radiation shield); 1 lb 7.4 oz (663.4 g) (OSA with radiation shield).
Agency Approvals: CE.

MODEL CHART					
Example	BTT	-D	04	-1	BTT-D04-1
Series	BTT				Temperature transmitter
Mounting Configuration		D I O R			Duct mount Immersion mount Outside air Outside air with radiation shield
Probe Length*			25 04 06 08 12 18		2.5" (required for "O" and "R" models) 4" 6" 8" 12" 18"
Output				1 2	4-20 mA 0-10 V
Options				Blank FC NIST	None Factory calibration certificate NIST calibration certificate
*For BTT-I models, actual probe length is approximately 0.75" longer than listed probe length to ensure maximum immersion into thermowells.					

THERMOWELLS - WELDED			
Model	Material	Connection (Internal/External)	Insertion Length
TE-TNS-N253N-00	304 SS	1/2" NPSM/1/2" NPT	2.5"
TE-TNS-N043N-00	304 SS	1/2" NPSM/1/2" NPT	4"
TE-TNS-N063N-00	304 SS	1/2" NPSM/1/2" NPT	6"
TE-TNS-N083N-00	304 SS	1/2" NPSM/1/2" NPT	8"
TE-TNS-N123N-00	304 SS	1/2" NPSM/1/2" NPT	12"
TE-TNS-N183N-00	304 SS	1/2" NPSM/1/2" NPT	18"

Dwyer
SERIES TTW

WEATHERPROOF IMMERSION TEMPERATURE TRANSMITTER

Pt100 RTD, PC Programmable Transmitter

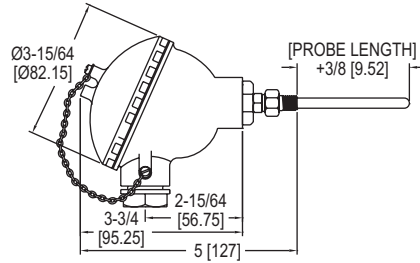

The Series TTW Weatherproof Immersion Temperature Transmitter offers a field adjustable temperature transmitter pre-assembled with an RTD sensor and weatherproof enclosure.

FEATURES/BENEFITS

- Preset to 32 to 212°F (0 to 100°C) output range
- USB port for easy output scale adjustment in the field

APPLICATIONS

- Immersion temperature sensing in HVAC systems

MODEL CHART

Model	Probe Length
TTW-104	4"
TTW-106	6"
TTW-108	8"
TTW-112	12"
TTW-118	18"

THERMOWELLS - MACHINED

Model	Material	Length	Connection (Internal/External) (NPT)
TE-TNS-N044N-14	304 SS	4"	1/4" / 1/2"
TE-TNS-N064N-14	304 SS	6"	1/4" / 1/2"
TE-TNS-N094N-14	304 SS	9"	1/4" / 1/2"
TE-TNS-N124N-14	304 SS	12"	1/4" / 1/2"

SPECIFICATIONS

TEMPERATURE SENSOR

Accuracy: ±3°F (±1.7°C).
Temperature Limits: Operating: -40 to 302°F (-40 to 150°C).
Sensor Curves: Pt100 RTD (TE Series Curve D).

TEMPERATURE TRANSMITTER

Input Range: -328 to 986°F (-200 to 530°C).
Output: Two-wire 4-20 mA.
Output Impedance: 600 Ω @ 24 VDC.
Power Requirements: 12-35 VDC.
Accuracy: ±0.2% FS.
Temperature Limits: -40 to 185°F (-40 to 85°C).
Response Time: <100 ms.

ENCLOSURE

Temperature Limits: -40 to 212°F (-40 to 100°C).
Rating: NEMA 4X (IP65).
Material: Painted aluminum housing.

FREE software download: See page 134 (Series TBU-00)



Machined thermowell

● Technical Specifications and Additional Thermowell Models: See page 31 (Series TE-TNS)

MODEL TBU-00

TEMPERATURE TRANSMITTER

Field Selectable, Universal Input, In-Head Mounting

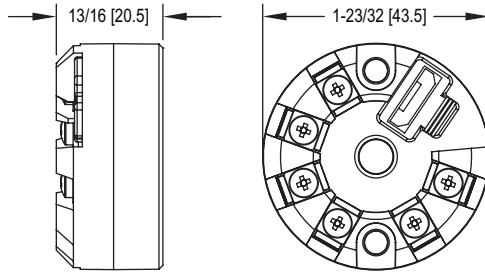

The Model TBU-00 Temperature Transmitter is a high precision temperature transmitter designed to easily mount in most temperature sensor instrument enclosures. The universal input reduces inventory while the micro-USB port facilitates easy configuration, and calibration in the lab or in the field. The versatile TBU model allows for selection and configuration of input type, measurement range, and calibration. The output can be set as either direct 4-20 mA, or reverse 20-4 mA, through easy to use configuration software.

FEATURES/BENEFITS

- Configurable measurement range
- Standard temperature sensor head enclosure mounting
- Pt100 connection for 2, 3, or 4 wires

APPLICATIONS

- Process applications where a 4-20 mA signal is required
- Food processing equipment
- Boiler equipment
- Refrigeration equipment

MODEL CHART

Model	Description
TBU-00*	Universal input temperature transmitter with customizable measurement ranges

*TBU-00 FREE downloadable configuration software available at www.dwyer-inst.com

ACCESSORIES

Model	Description
A-709	NEMA 4X aluminum transmitter enclosure
UHH-CBL2	USB to micro-USB cable

SPECIFICATIONS

Input: Thermocouples J, K, R, S, T, N, E, and B; 2, 3, or 4 wire Pt100 RTD, 2 or 3 wire Pt1000 RTD, 2 wire NTC thermistor, or 0-50 mV voltage.
Output: Linearized 4-20 mA, 2 wire or 20-4 mA loop powered.
Transmitter Type: 2, 3, or 4 wire.
Temperature Limits: -40°F to 185°F (-40 to 85°C).
Power Requirements: 10-35 VDC.
Accuracy: See chart below.
Temperature Drift: < ±0.16% / 25°C.
Response Time: 1.6 s, typical.
Weight: 1.4 oz (40 g).
Agency Approvals: CE.

Note: Factory set to Pt100 Ω RTD, 0 to 100°C, direct acting

ACCURACY CHART

Input Type	Temperature Range	Accuracy (Typical)
Thermocouples and mV	Configured with software	±0.1% FS
Pt100/ Pt1000 RTDs	-328 to 1202°F (-200 to 650°C) -238 to 752°F (-150 to 400°C)	±0.13% FS ±0.1% FS



EXPLOSION-PROOF RTD TEMPERATURE TRANSMITTER

User Selectable Ranges, Optional LCD Display



*Shown with optional LCD display

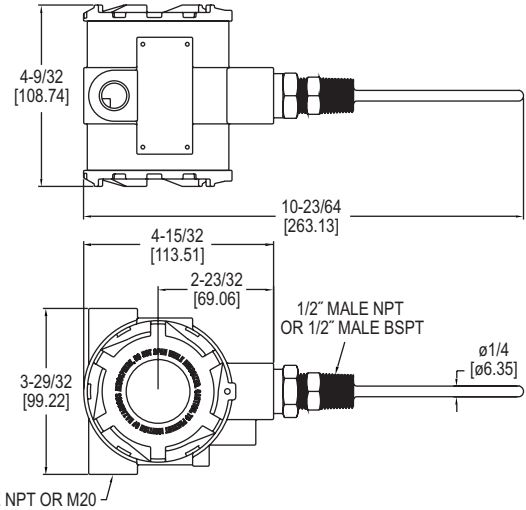

The Series TTE Explosion-Proof RTD Temperature Transmitter is the ideal product for hazardous temperature measurement applications. The TTE series has seven pre-programmed temperature ranges that are selectable via an internal dip switch. For those applications that need a custom range, the transmitter can be easily configured for any range between -30 to 250°F with a minimum span of 40°F. The span and zero can be quickly adjusted with a simple push-button design. This unit has optional listings of FM for use in Class I, Division 1, Groups B, C and D, Class II, Division 1, Groups E, F and G and Class III atmospheres or ATEX (Directive 2014/34/EU) for **CE** **Ex** II 2 G Ex db IIC T6...T4 Gb (-20°C ≤ Ta ≤ +70°C), **CE** **Ex** II 1 D Ex ta IIIC T111°C Da (-20°C ≤ Ta ≤ +70°C) and IECEx for Ex db IIC T6...T4 Gb (-20°C ≤ Ta ≤ +70°C), Ex ta IIIC T111°C Da (-20°C ≤ Ta ≤ +70°C). The compact housing allows for the transmitter to be mounted in virtually any application.

FEATURES/BENEFITS

- FM approved for Class I, Groups B, C, D; Class II, Groups E, F, G classified explosive environments
- Optional LCD
- Output span selected from seven common ranges or user determined

APPLICATIONS

- Explosive process environments
- Offshore HVAC monitoring

SPECIFICATIONS

Temperature Sensor: Pt1000, 0.00385 DIN.
Output Temperature Ranges: User selectable – any range between -30 to 250°F with a minimum span of 40°F.
Temperature Limits: Ambient: -4 to 158°F (-20 to 70°C); Process: -30 to 250°F (-34.4 to 120°C).
Accuracy: Transmitter ±0.1% FS; Probe ±0.3% FS.
Thermal Drift Effects: ±0.02%/°C max.
Response Time: 250 ms.
Wetted Materials: 316 SS.
Process Connection: 1/2" male NPT or 1/2" male BSPT.
Conduit Connection: 1/2" female NPT or M20.
Probe Length: 2" to 18" (depending on model).
Pressure Limits: 2000 psi (137.9 bar).
Power Requirements: 10 to 35 VDC.
Output Signal: 4 to 20 mA (two wire loop powered).
Optional Display: 2 lines X 8 character LCD.
Enclosure Rating: Weatherproof and Explosion-proof. Listed with FM for Class I, Division 1, Groups B, C and D, and dust-ignitionproof for Class II, Division 1, Groups E, F and G and Class III atmospheres.
ATEX Certified: **CE** 0518 **Ex** II 2 G Ex db IIC T6...T4 Gb, **CE** **Ex** II 1 D Ex ta IIIC T111°C Da, T6 Process Temp ≤80°C, Temperature Class T5 Process Temp ≤95°C, Temperature Class T4 Process Temp ≤120°C as defined on nameplate. EU-type Certificate No.: EMT17ATEX0021 X.
 ATEX Standards: EN 60079-0:2012+A11:2013; EN 60079-1:2015; EN 60079-31:2014.
IECEx Certified: For Ex db IIC T6...T4 Gb, Ex ta IIIC T111°C Da, T6 Process Temp ≤80°C, Temperature Class T5 Process Temp ≤95°C, Temperature Class T4 Process Temp ≤120°C as defined on nameplate.
IECEx Certificate of Conformity: Element IECEx EMT 17.0007X; IECEx Standards: IEC 60079-0:2011 (Edition 6); IEC 60079-1:2014 (Edition 7); IEC 60079-31:2013 (Edition 2).
Weight: 2 lb 8 oz (1134 g).
Agency Approvals: FM, CE, ATEX/IECEx.

MODEL CHART						
Example	TTE	-1	04	-W	-LCD	TTE-104-W-LCD
Series	TTE					Explosion-proof RTD temperature transmitter
Agency		1				FM* ATEX/IECEx flameproof
Probe Length			02			2" probe
			04			4" probe
			06			6" probe
			09			9" probe
			12			12" probe
			15			15" probe
			18			18" probe
Construction				W		Well probe
Options					Blank	No LCD display
					BSPT	1/2 male BSPT process connection
					C5	C5-M housing paint specification
					LCD	LCD display
				M20	Female M20 thread electrical connection	

*Options that do not have ATEX and IECEx.

Attention: Units without the "2" suffix following "TTE" are not directive 2014/34/EU (ATEX) Compliant. These units are not intended for use in potentially hazardous atmospheres in the EU. These units may be CE marked for other directives of the EU.

ACCESSORIES

Model	Description
A-287	Mounting bracket for pipe or surface mounting (Includes bracket and two 2" U-bolts)

THERMOWELLS - MACHINED			
Model	Material	Length	Connection (Internal/External) (NPT)
TE-TNS-N044N-12	304 SS	4"	1/2" / 3/4"
TE-TNS-N064N-12	304 SS	6"	1/2" / 3/4"
TE-TNS-N094N-12	304 SS	9"	1/2" / 3/4"
TE-TNS-N124N-12	304 SS	12"	1/2" / 3/4"



Machined thermowell

FIELD-SELECTABLE RANGES

40 to 90°F (4.4 to 32.2°C)
 -20 to 140°F (-28.9 to 60°C)
 0 to 100°F (-17.8 to 37.8°C)
 30 to 240°F (-1.1 to 115.6°C)
 32 to 212°F (0 to 100°C)
 32 to 122°F (0 to 50°C)
 -30 to 65°C (-1.1 to 18.3°C)
 Custom range between -30 to 250°F (-34.4 to 121.1°C)

Technical Specifications and Additional Thermowell Models: See page 31 (Series TE-TNS)

WALL MOUNT HUMIDITY/TEMPERATURE/DEW POINT TRANSMITTERS

Optional LCD Display

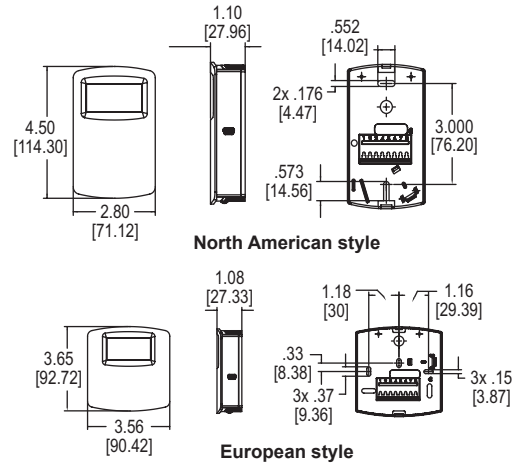
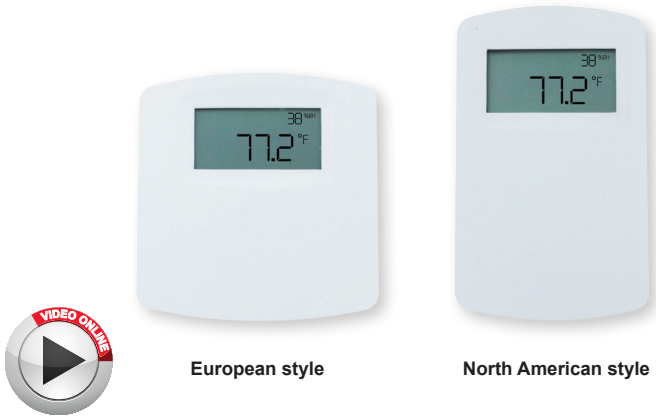

The Series RHP-E/N Wall Mount Humidity/Temperature/Dew Point Transmitters are the most versatile room transmitter on the market. The stylish housing is well vented to provide air flow across the sensor to improve measurement accuracy. The humidity and the dew point are measured using a capacitive polymer sensor. The humidity and dew point can have either a current or voltage output, while the optional temperature output can be a current, voltage, RTD or thermistor. For models with current or voltage for the temperature output, the temperature range is field selectable.

FEATURES/BENEFITS

- Field selectable relative humidity or dew point output
- Universal analog outputs
- Integral or service tool LCD display options
- Two housing designs to match North American and European aesthetics

APPLICATIONS

- Air economizers
- Room comfort monitoring
- Greenhouse monitoring

SPECIFICATIONS	
Relative Humidity Range: 0 to 100% RH.	0-5/10V Outputs: Power requirements: 15-35 VDC or 15-29 VAC; Output load: 5 mA max., 2 channels for humidity/solid state temperature sensor models. Switch selectable 0-10 V/2-10 V or 0-5 V/1-5 V output. Switch selectable RH/dew point. Switch selectable normal or reverse output.
Temperature Range: -40 to 140°F (-40 to 60°C) for thermistor and RTD sensors. -20 to 140°F (-28.9 to 60°C) for solid state band gap temperature sensors.	Solid State Band Gap Temperature Sensor Output Ranges: Switch selectable, -20 to 140°F (-28.9 to 60°C); 0 to 100°F (-17.8 to 37.8°C); 40 to 90°F (4.4 to 32.3°C); -4 to 140°F (-20 to 60°C) field-selectable ranges.
Dew Point Temperature Range: -20 to 140°F (-28.9 to 60°C); 0 to 100°F (-17.8 to 37.8°C); 40 to 90°F (4.4 to 32.3°C); -4 to 140°F (-20 to 60°C) field-selectable ranges.	Response Time: 8 s.
Accuracy: RH: Model RHP-2XXX ±2% 10 to 90% RH @ 25°C; Model RHP-3XXX ±3% 20 to 80% RH @ 25°C; Model RHP-5XXX ±5% 20 to 80% RH @ 25°C; Thermistor temperature sensor: ±0.36°F @ 77°F (±0.2°C @ 25°C); RTD temperature sensor: DIN Class B; ±0.54°F @ 32°F (±0.3°C @ 0°C); Solid state band gap temperature sensor: ±0.9°F @ 77°F (±0.3°C @ 25°C).	Electrical Connections: Screw terminal block.
Hysteresis: ±0.8%.	Drift: <0.25% RH/year.
Repeatability: ±0.1% typical.	RH Sensor: Capacitance polymer.
Temperature Limits: Operating: -40 to 140°F (-40 to 60°C); Storage: -40 to 176°F (-40 to 80°C).	Enclosure Material: Polycarbonate.
Compensated Temperature Range: -4 to 140°F (-20 to 60°C).	Enclosure Rating: IP20.
4-20 mA Loop Powered Outputs: Power requirements: 10-35 VDC; Output signal: 4-20 mA, 2 channels for humidity/solid state temperature sensor models (loop powered on RH). Switch selectable RH/dew point. Switch selectable normal or reverse output.	Display: Optional LCD; Switch selectable %RH or dew point, °F/°C.
	Display Resolution: RH: 1%; Temperature: 0.1°F (0.1°C); Dew point: 1°F (1°C).
	Weight: 4.4 oz (125 g).
	Agency Approvals: CE.

MODEL CHART						
Example	RHP	-3	N	4	A	-LCD RHP-3N4A-LCD
Series	RHP					Humidity/temperature/dew point transmitter
Accuracy		2 3 5				2% accuracy 3% accuracy 5% accuracy
Housing			E N			European style wall mount North American style wall mount
Humidity/Dew Point Output				4		4-20 mA/0-5 VDC/0-10 VDC
Temperature Output					0 4 A B C D E F	None 4-20 mA/0-5 VDC/0-10 VDC 10K Ω @ 25°C thermistor type III 10K Ω @ 25°C thermistor type II 3K Ω @ 25°C thermistor 100 Ω RTD DIN 385 1K Ω RTD DIN 385 20K Ω @ 25°C thermistor
Options					LCD NIST	LCD display NIST traceable calibration certificate

ACCESSORIES	
Model	Description
A-449	Remote LCD display allows remote indication of select Dwyer wall mount transmitters for validation or certification purposes
SCD-PS	100-240 VAC/VDC to 24 VDC power supply



WALL MOUNT HUMIDITY/TEMPERATURE TRANSMITTER

2% or 3% Humidity Sensor, Passive Temperature Outputs

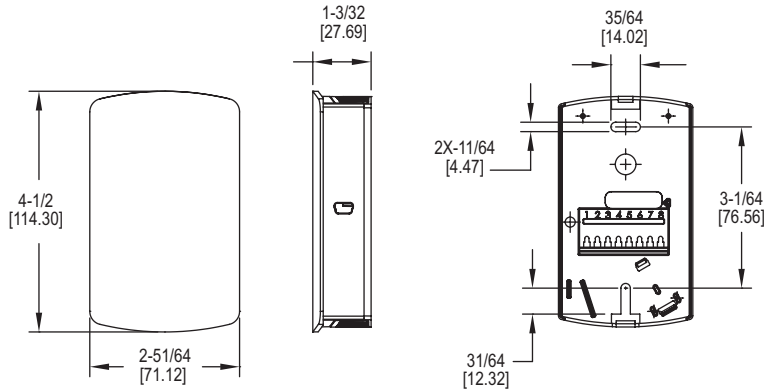

The Series RHPLC Wall Mount Humidity/Temperature Transmitter is a compact economical sensor for the building automation marketplace. The stylish housing is well vented to provide air flow across the sensor to improve measurement accuracy. Each unit utilizes a capacitive polymer sensing element to deliver a proportional analog output. A combination humidity and temperature model can be configured with current, voltage, RTD, or thermistor output. A wide selection of passive RTD or thermistor temperature sensors are available in this series.

FEATURES/BENEFITS

- 2% or 3% accuracy models
- Humidity only or temperature and humidity combo
- Wide selection of passive thermistor or RTD temperature sensors

APPLICATIONS

- Air economizers
- Room comfort monitoring

SPECIFICATIONS

Sensor: Capacitive polymer.
Relative Humidity Range: 0-100% RH.
RH Accuracy: ±2% 10 to 90% RH @ 25°C for 2% accuracy units; ±3% 20 to 80% RH @ 25°C for 3% accuracy units.
RH Hysteresis: ±0.8%.
RH Repeatability: ±0.1% typical.
Temperature Output Range: -40 to 140°F (-40 to 60°C).
Passive Thermistor Temperature Sensor Accuracy: ±0.36°F @ 77°F (±0.2°C @ 25°C).
Accuracy RTD Temp Sensor: DIN Class B; ±0.3°C @ 0°C (±0.54°F @ 77°F).
Accuracy Current/Voltage Temperature Output: ±0.9°F @ 72°F (±0.3°C @ 25°C).
Temperature Limits: Operating: -40 to 140°F (-40 to 60°C); Storage: -40 to 176°F (-40 to 80°C).
Power Requirements: 10-35 VDC for 4-20 mA or 0-5 VDC output; 15-35 VDC for 0-10 VDC output; 10-29 VAC for 0-5 VDC output; 15-29 VAC for 0-10 VDC output.
Response Time: 8 s (T63).
Electrical Connections: Screw terminal block.
Drift: <0.25% RH/year.
Enclosure Material: Polycarbonate.
Weight: 4.4 oz (125 g).
Agency Approvals: CE.

MODEL CHART							
Example	RHPLC	-3	N	2	A	-FC	RHPLC-3N2A-FC
Series	RHPLC						Humidity/temperature transmitter
Accuracy		2					2% accuracy
		3					3% accuracy
Housing			N				North American style wall mount
Humidity Output				1			Current 4-20 mA
				2			Voltage 0-10 VDC
				3			Voltage 0-5 VDC
Temperature Output					0		None
					1		Current 4-20 mA
					2		Voltage 0-10 VDC
					3		Voltage 0-5 VDC
					A		10K Ω @ 25°C thermistor type III
					B		10K Ω @ 25°C thermistor type II
					C		3K Ω @ 25°C thermistor
					D		100 Ω RTD DIN 385
				E		1K Ω RTD DIN 385	
				F		20K Ω @ 25°C thermistor	
Options						FC	Factory calibration certificate (3% accuracy units)

ACCESSORIES	
Model	Description
SCD-PS	100-240 VAC/VDC to 24 VDC power supply
APT-40-5DN	AC power transformer, 120/208/240/277/480 VAC input, 24 VAC isolated output, 40 VA, dual hub

HUMIDITY/TEMPERATURE TRANSMITTERS

Passive Temperature Outputs, Sintered Filter Options

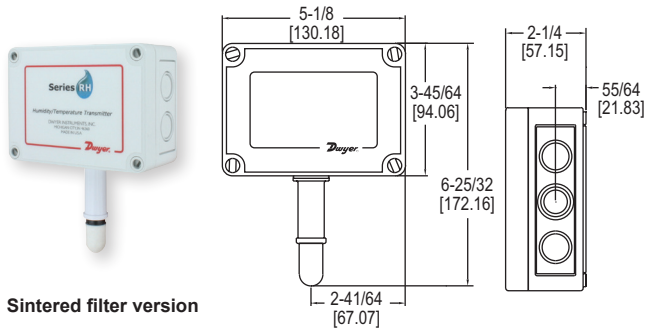

Sintered filter version

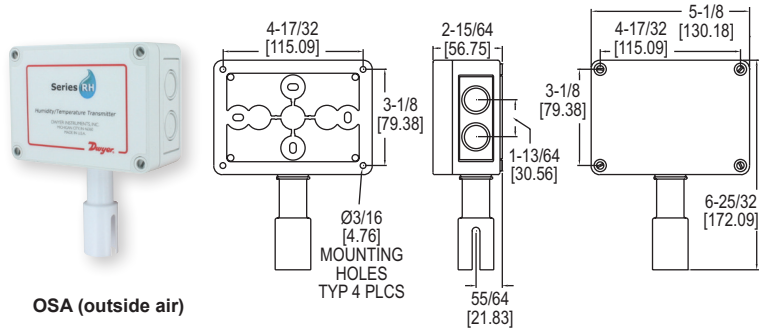

OSA (outside air)



Duct mount

Duct sintered

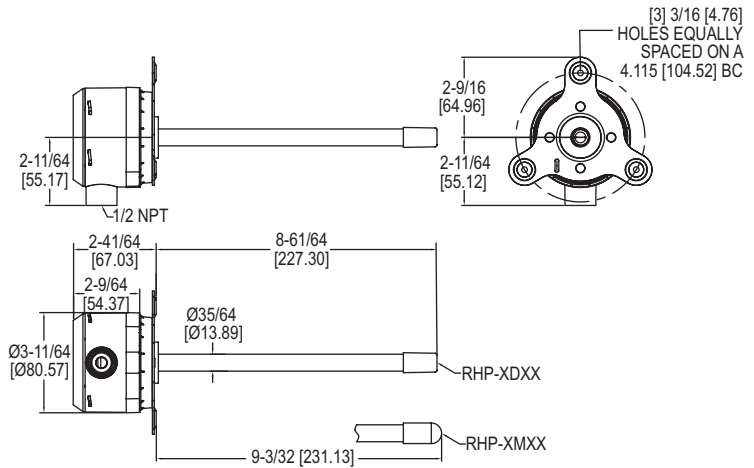

The Series RHP Temperature and Humidity Transmitters combine the voltage or current humidity transmitter output with a passive temperature thermistor or RTD output. Featuring polymer capacitance humidity sensors, models are available with 2%, 3% or 5% accuracies. Duct mounted transmitters are available with an optional two-line alpha numeric LCD display.

FEATURES/BENEFITS

- 2%, 3%, or 5% accuracy models
- Optional LCD display on duct mount models
- Radiation shield option for outdoor installation in direct sunlight

APPLICATIONS

- Air economizers
- Outdoor temperature and relative humidity reference
- Pool room humidity monitoring

SPECIFICATIONS

Relative Humidity Range: 0 to 100% RH.
Temperature Range: -40 to 140°F (-40 to 60°C).
Accuracy, RH: RHP-2XXX ±2% 10-90% RH @ 25°C; RHP-3XXX ±3% 20-80% RH @ 25°C; RHP-5XXX ±5% 20-80% RH @ 25°C.
Accuracy, Thermistor Temp Sensor: ±0.2°C @ 25°C (±0.36°F @ 77°F).
Accuracy, RTD Temp Sensor: DIN Class B; ±0.3°C @ 0°C (±0.54°F @ 32°F).
Accuracy, Solid State Band Gap: ±0.9°F @ 77°F (±0.3°C @ 25°C).
Hysteresis: ±1%.
Repeatability: ±0.1% typical.
Temperature Limits: -40 to 140°F (-40 to 60°C).
Storage Temperature: -40 to 176°F (-40 to 80°C).
Compensated Temperature Range: -4 to 140°F (-20 to 60°C).
4-20 mA Loop Powered Models: Power requirements: 10-35 VDC; Output signal: 4-20 mA.
0-5/10V Output Models: Power requirements: 15-35 VDC or 15-29 VAC; Output signal: 0-10 V @ 5 mA max.
Solid State Band Gap Temperature Sensor Output Ranges: Switch selectable, -20 to 140°F (-28.9 to 60°C); 0 to 100°F (-17.8 to 37.8°C); 40 to 90°F (4.4 to 32.3°C); -4 to 140°F (-20 to 60°C).
Response Time: 15 s.
Electrical Connections: Removable screw terminal block.
Conduit Connection: Duct mount: 1/2" NPS; OSA: 1/2" (22.3 mm).
Drift: < 1% RH/year.
RH Sensor: Capacitance polymer.
Temperature Sensor: Types 1, 2, 3: Solid state band gap; Curves A, B, C: Thermistor; Curves D, E: Platinum RTD DIN 385.
Enclosure: Duct mount: PBT; OSA: Polycarbonate.
Enclosure Rating: Duct mount: NEMA 4X (IP66) for housing only; OSA: NEMA 4X (IP66).
Display: Duct mount only, optional 2-line alpha numeric, 8 characters/line.
Display Resolution: RH: 0.1%; 0.1°F (0.1°C).
Weight: Duct mount: .616 lb (.3 kg); OSA: 1 lb (.45 kg).
Agency Approvals: CE.

MODEL CHART						
Example	RHP	-2	D	1	A	-LCD RHP-2D1A-LCD
Series	RHP					RH/passive temperature sensor transmitter
Accuracy		2 3 5				2% accuracy 3% accuracy 5% accuracy
Housing Type			D M O S R			Duct mount with filter Duct mount with HDPE filter OSA (outside air) OSA with sintered filter* Radiation shield
RH Output				1 2 3		4-20 mA 0-10 V 0-5 VDC
Temperature Sensor					0 1 2 3 A B C D E F	None 4-20 mA 0-10 VDC 0-5 VDC 10K @ 25°C thermistor type III 10K @ 25°C thermistor type II 3K @ 25°C thermistor 100 Ω RTD DIN 385 1K Ω RTD DIN 385 20K Ω @ 25°C thermistor
Options					LCD NIST	LCD display NIST traceable calibration certificate

*Use OSA with sintered filter models when purchasing Series RHRS radiation shield separately.

OUTSIDE AIR HUMIDITY RADIATION SHIELDS

6 or 10 Plate Design, Integral Pipe Mounting Kit

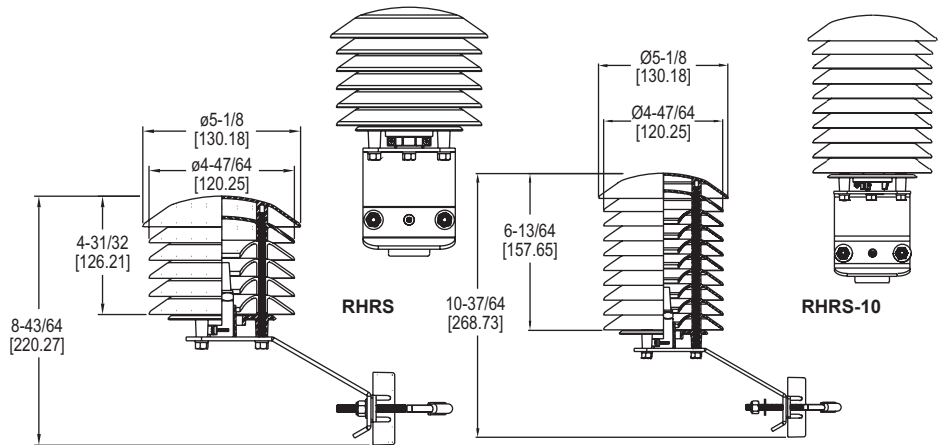
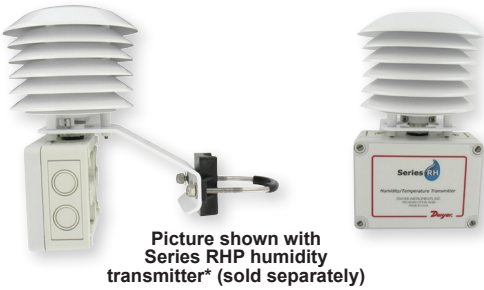

The Series RHRS Outside Air Humidity Radiation Shields protects outside air humidity transmitters from rain and radiated heat. With the curved shape and color of the plates, air flow is able to move across the sensor to keep radiated temperatures from rooftops and surrounding surfaces from affecting humidity readings.

FEATURES/BENEFITS

- Adjustable sensor mounting collar works with Dwyer RHP sintered filter outdoor air humidity transmitters or other RH devices
- Universal mount fits 3/4" to 1-1/2" pipe or flat surfaces

APPLICATIONS

- Building outside air reference
- Weather stations

MODEL CHART	
Model	Description
RHRS	6 plate radiation shield
RHRS-10	10 plate radiation shield
Note: Only sintered filter OSA models of Series RHP are compatible with the shield.	

SERIES WHT

WEATHER-RESISTANT HUMIDITY/TEMPERATURE TRANSMITTER

Compact Housing, Sintered Filter

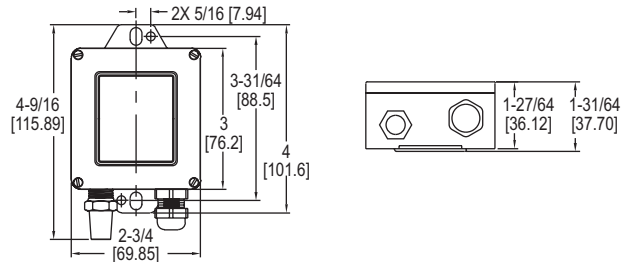

The compact Series WHT Weather-Resistant Humidity/Temperature Transmitter is designed to withstand the elements. A removable sintered filter protects the polymer capacitance sensor from solid objects that may come in contact with the transmitter. The transmitter is available with 4-20 mA or 0-10 VDC output signals for both temperature and humidity. This transmitter is ideal for measuring outside air temperature and humidity levels for air handling economizer applications.

FEATURES/BENEFITS

- RH or RH and temperature outputs
- Compact NEMA 3S construction

APPLICATIONS

- Air handling economizers
- Air environment monitoring in agriculture or livestock cultivation houses

MODEL CHART			
Model	Accuracy	RH Output	Temperature
WHT-310	3%	4-20 mA	None
WHT-311	3%	4-20 mA	4-20 mA
WHT-320	3%	0-10 VDC	None
WHT-322	3%	0-10 VDC	0-10 VDC
WHT-330	3%	0-5 VDC	None
WHT-333	3%	0-5 VDC	0-5 VDC
WHT-31A	3%	4-20 mA	10K Ω Type III
WHT-32A	3%	0-10 VDC	10K Ω Type III
Note: For 2% accuracy, change the leading 3 to a 2. Example: WHT-210.			

SPECIFICATIONS
Relative Humidity Range: 0 to 100% RH.
Temperature Range: -40 to 140°F (-40 to 60°C).
Accuracy, RH: $\pm 3\%$ 20 to 80% RH, $\pm 4\%$ @ 10-20%, 80 to 90%.
Accuracy, Temp Models with 4 to 20 mA Temp. Output: $\pm 0.9^\circ\text{F}$ @ 72°F ($\pm 0.3^\circ\text{C}$ @ 25°C).
Accuracy, Temp Models with Passive Thermistor Temp Sensor: $\pm 0.36^\circ\text{F}$ @ 77°F ($\pm 0.2^\circ\text{C}$ @ 25°C).
Hysteresis, RH: $\pm 1\%$.
Repeatability, RH: $\pm 0.1\%$ typical.
Temperature Limits: -40 to 140°F (-40 to 60°C).
Storage Temperature: -40 to 176°F (-40 to 80°C).
Compensated Temperature Range, RH: -4 to 140°F (-20 to 60°C).
4-20 mA Loop Powered Models: Power requirements: 10-35 VDC; Output signal: 4-20 mA.
0-10 V Output Models: Power requirements: 15-35 VDC or 15-29 VAC; Output signal: 0-10 V @ 5 mA max.
0-5 V Output Models: Power requirements: 10-35 VDC or 10-29 VAC; Output signal: 0-5 V @ 5 mA max.
Response Time: 15 s.
Electrical Connections: Removable screw terminal block.
Drift: < 1% RH/year.
RH Sensor: Capacitance polymer.
Temperature Sensor: 4-20 mA output, solid state band gap. Passive output: 10K @ 25°C thermistor (Dwyer curve A).
Enclosure: ABS.
Enclosure Rating: Designed to meet NEMA 3S (IP54).
Weight: 0.3 oz (8.5 g).
Agency Approvals: CE.



SERIES RH-R

HUMIDITY/TEMPERATURE TRANSMITTER

Remote Mount, Field Replaceable Sensor Filter, Up to 16' Cable

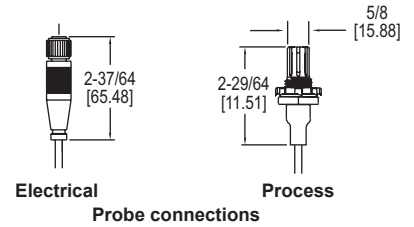
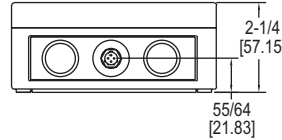
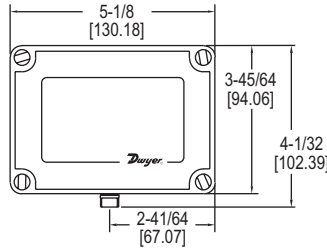

The Series RH-R Humidity and Temperature Transmitter is the ideal transmitter for those applications where space is limited. The compact sensor is protected by a removable filter. It can be mounted up to 16 feet away from the weatherproof base. The Series RH-R is ideal for environmental chambers, rubber bladder burst detection and air handler applications.

FEATURES/BENEFITS

- Cable lengths from 4 to 16'
- Remote housing allows for flexibility sensing where space may be limited

APPLICATIONS

- Process system monitoring
- Environmental chambers
- Air economizers

SPECIFICATIONS

Service: Dry clean air.
Relative Humidity Range: 0 to 100% RH.
Temperature Range: -40 to 140°F (-40 to 60°C).
Accuracy: ±2% @ 10-90%.
Temperature Limits: -40 to 140°F (-40 to 60°C).
Storage Temperature: -40 to 176°F (-40 to 80°C).
Compensated Temperature Range: -4 to 140°F (-20 to 60°C).

Power Requirements: 10-35 VDC.
Output Signal: 4-20 mA loop powered.
Response Time: Less than 15 s.
Electrical Connections: Terminal block.
Conduit Connection: 1/2" NPT.
Process Connection: 1/2" NPSM.
Drift: < 1%/year.
RH Sensor: Capacitance polymer
Cable Length: Up to 16'.
Housing Material: Polycarbonate, aluminum enclosure.
Enclosure Rating: NEMA 4X (IP66).

MODEL CHART

Model	Cable Length	Description	Output	Model	Cable Length	Description	Output
RHU-R004	4'	Humidity	Current	RHT-R004	4'	Humidity/temperature	Current
RHU-R008	8'	Humidity	Current	RHT-R008	8'	Humidity/temperature	Current
RHU-R012	12'	Humidity	Current	RHT-R012	12'	Humidity/temperature	Current
RHU-R016	16'	Humidity	Current	RHT-R016	16'	Humidity/temperature	Current

SERIES 657

RELATIVE HUMIDITY/TEMPERATURE TRANSMITTERS

Dual Channel Design for Simultaneous 4 to 20 mA Output Signals

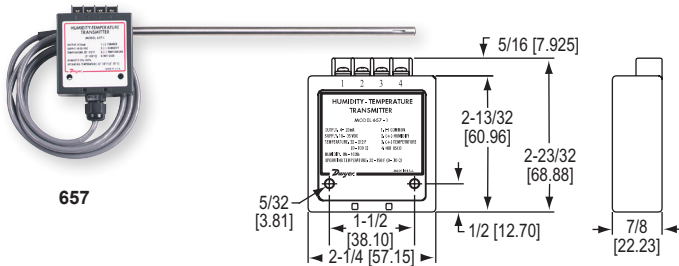

The Series 657 Relative Humidity/Temperature Transmitters provide two 4-20 mA channels to produce separate output signals for both relative humidity and temperature. These devices deliver ±2% accuracy for humidity and ±1°F for temperature measurements. Stainless steel probe can be easily mounted to most ductwork using either of the two optional kits below.

FEATURES/BENEFITS

- Polymer film humidity and thin film RTD temperature sensors offer highly reliable and stable measurements.
- Remote mount housing offers installation flexibility (657-1)
- Rugged die-cast aluminum housing is great for industrial applications (657C-1)

APPLICATIONS

- Cleanroom monitoring
- HVAC/building control monitoring

MODEL CHART

Model	Description
657-1	RH/temperature transmitter
657C-1	RH/temperature transmitter - conduit housing

ACCESSORIES

Model	Description
A-158	Split flange
A-159	Mounting gland

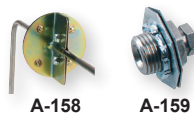

SPECIFICATIONS

Service: Dry clean air.
Range: Relative humidity: 0 to 100%; Temperature: 32 to 212°F (0 to 100°C).
Accuracy: Relative humidity: ±2% (10 to 90% RH), ±3% (0 to 10% and 90 to 100% RH); Temperature ±1°F (0.5°C).
Temperature Limits: 32 to 140°F (0 to 60°C).
Pressure Limits: 1 psi (.07 bar).
Compensated Temperature Range: 32 to 140°F (0 to 60°C).
Power Requirements: 10-35 VDC.
Output Signal: 2 channels each 4-20 mA. Loop powered on the RH channel.
Electrical Connections: 4 screw type terminals.
Mounting Orientation: Mount in any position.
Probe: 657-1: Stainless steel 5/16" x 10" (0.8 x 25.4 cm); 657C-1: 5/16" x 9-1/10" (0.8 x 23.1 cm).
Weight: 657-1: 5.5 oz (156 g); 657C-1: 10 oz (284 g).

OPTIONS

To order add suffix:	Description
-NIST	NIST traceable humidity calibration certificate
Example: 657C-1-NIST	

CARBON DIOXIDE/TEMPERATURE TRANSMITTERS

NDIR CO₂ Sensor, Universal Outputs, Optional Relay



European style

North American style



Duct

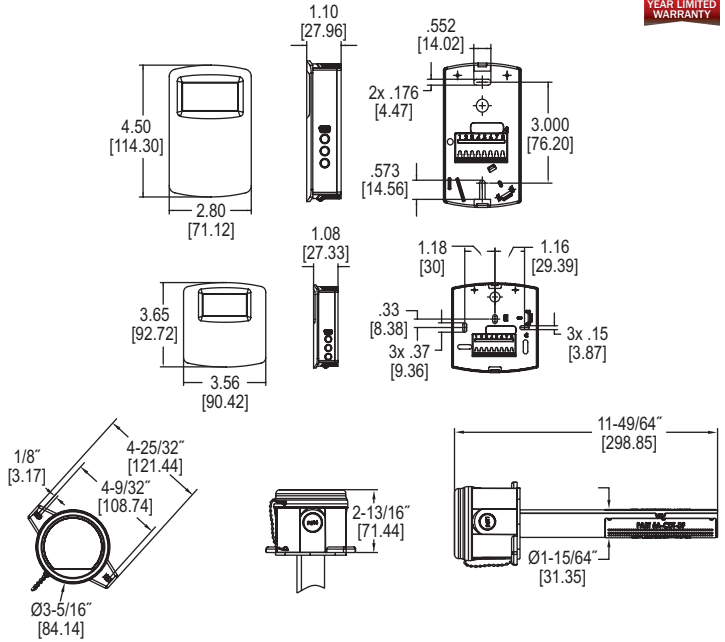

The **Series CDT Carbon Dioxide and Temperature Transmitters** accurately monitor the CO₂ concentration and temperature in indoor environments to help achieve energy savings. For increased sensor accuracy, a single beam dual wavelength non-dispersive infrared (NDIR) sensor is used to automatically correct the measurement in both occupied* and unoccupied buildings against light source aging effects. The single beam dual wavelength sensor technology provides the highest level of accuracy compared to Automatic Baseline Correction methods which can unintentionally shift the calibration based on CO₂ levels and barometric pressure conditions. In order to achieve a higher level of accuracy, the Series CDT includes digital barometric pressure adjustment and the ability to field-calibrate the sensor. For applications that require visual indication, the wall mount configurations of the Series CDT can be ordered with an integral LCD display. Push-buttons are standard on all configurations of the transmitters for access to the menu structure, but wall mount configurations can be ordered without the buttons. To prevent tampering, the action of the buttons can be locked out using an internal dip switch selection.

FEATURES/BENEFITS

- Single beam dual wavelength NDIR sensor eliminates drift due to light source aging
- Integral passive temperature outputs reduce number of devices mounted in the space
- Service display tool available for models without an integral LED
- Optional integral display and relay output

APPLICATIONS

- Demand control ventilation in schools, office buildings, hospitals, and other indoor environments
- LEED® certification

*For buildings occupied 24 hours per day, it is recommended that calibration be verified every 6 to 12 months depending on application.

SPECIFICATIONS

Sensor: Single beam, dual wavelength NDIR.
Range: CO₂: 0 to 2000 or 0 to 5000 PPM (depending on model); Temperature: 32 to 122°F (0 to 50°C).
Accuracy: CO₂: ±40 PPM ±3% of reading; Temperature: ±1°C @ 25°C.
Temperature Dependence: ±8 PPM/°C at 1100 PPM.
Non-Linearity: 16 PPM.
Pressure Dependence: 0.13% of reading per mm of Hg.
Response Time: 2 min for 99% step change.
Duct Air Velocity Range: 0-4000 FPM (20.32 m/s).
Temperature Limits: 32 to 122°F (0 to 50°C).
Humidity Limits: 10 to 95% RH (non-condensing).
Power Requirements: 16-35 VDC or 19-28 VAC.
Power Consumption: Average: 2 w; Peak: 3.75 w.
Output: Current: 4-20 mA (max. 500 Ω); Voltage: 0-5 VDC or 0-10 VDC (min. 500 Ω); Relay: SPST NO rated 2 A @ 30 VDC.
Weight: 4.4 oz (125 g).
Enclosure Rating: Duct mount: NEMA 4X (IP66) for housing only; Wall mount: IP20.
Agency Approvals: CE.

MODEL CHART						
Example	CDT	-2	N	4	4	-LCD
Series	CDT					Carbon dioxide/temperature transmitter
Range		2 5				0 to 2000 PPM CO ₂ range 0 to 5000 PPM CO ₂ range
Configuration			N E D			North American style wall mount European style wall mount Duct mount
CO ₂				4		4-20 mA / 0 to (5 or 10) VDC
Temperature Output					0 4 A B C D E F	None 4-20 mA / 0 to (5 or 10) VDC 10 KΩ NTC thermistor type III 10 KΩ NTC thermistor type II 3 KΩ NTC thermistor Pt100 Ω RTD Pt1000 Ω RTD 20 KΩ NTC thermistor
Options						FC Factory calibration certificate LCD LCD display (wall only) RLY Relay NBC No buttons (wall only)

ACCESSORIES	
Model	Description
GCK-200CO-2000CO2	Calibration gas kit includes a 99.99% nitrogen gas cylinder for calibrating the zero point and a 200 PPM CO / 2000 PPM CO ₂ gas cylinder for calibrating the span point on Dwyer's gas sensing transmitters
A-449	Remote LCD display allows remote indication of select Dwyer® wall mount transmitters for validation or certification purposes
A-449A	Remote LCD display with buttons allows remote indication and calibration of select Dwyer® wall mount transmitters for validation and certification purposes
A-CDT-KIT	Accessory kit including terminal block and power supply



GCK-200CO-2000CO2



A-449

COMMUNICATING CARBON DIOXIDE DETECTORS

Measures CO₂, Humidity, Temperature, Temperature Set Point, and Override



European style

North American style

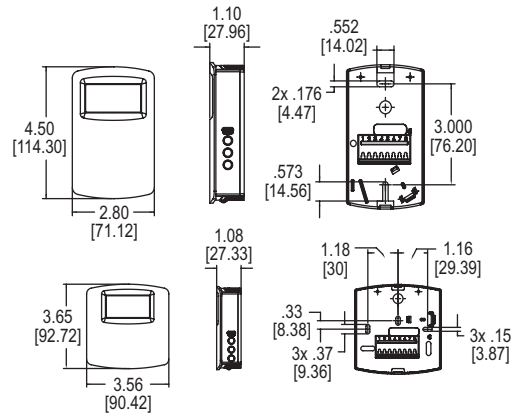

The Series CDTA Communicating Carbon Dioxide Detectors combine the function of three room sensors into a single, compact housing. Parameters include carbon dioxide, humidity, temperature, and temperature set point with override. By having field selectable Modbus® and BACnet Communications, only four wires are needed for power and the communication signal. The communicating detectors can be daisy chained together to further reduce installation cost. In order to reduce the set up time, the RS-485 MAC address is set up using on board dip switches. A second set of dip switches are used to select whether output is Modbus® RTU or BACnet MS/TP communication protocols and to limit access to the set up menu.

Like our Series CDT Carbon Dioxide Transmitter, the Series CDTA uses a Single Beam Dual Wavelength Non-Dispersive Infrared (NDIR) sensor to measure the carbon dioxide level. This technology can be used in installations that will be occupied 24 hours per day. For improved accuracy, the transmitter can be field calibrated to the environmental conditions of the installation. Also, the barometric pressure can be programmed to correct for altitude. The humidity uses a capacitive polymer sensor and the temperature is measured using a 10KΩ thermistor sensor. The humidity sensor is field replaceable without the need for additional calibration.

Optional local and remote displays are available to display any of the parameters. For applications in which the building occupants aren't familiar with CO₂ concentrations, the LCD can be programmed to display temperature, humidity, or temperature set point instead.

FEATURES/BENEFITS

- Digital Intelligent Temperature Compensation Algorithm (DITCA) corrects for errors due to self heating effects of combination wall sensors
- Field selectable Modbus® and BACnet communications reduces wiring
- Single beam dual wavelength CO₂ sensor
- Replaceable humidity/temperature sensor
- Physical hardware lockout
- Optional remote display tool

APPLICATIONS

- Demand control ventilation in schools, office buildings, hospitals, and other indoor environments
- LEED® certification

MODEL CHART			
Model	CO ₂ Concentration	Housing Style	Display
CDTA-2N000	2000 PPM	North American	No
CDTA-2N000-LCD	2000 PPM	North American	Yes
CDTA-2E000	2000 PPM	European	No
CDTA-2E000-LCD	2000 PPM	European	Yes
CDTA-5N000	5000 PPM	North American	No
CDTA-5N000-LCD	5000 PPM	North American	Yes
CDTA-5E000	5000 PPM	European	No
CDTA-5E000-LCD	5000 PPM	European	Yes

OPTIONS	
To order add suffix:	Description
-FC	Factory calibration certificate
Example: CDTA-2N000-FC	

SPECIFICATIONS

Sensor (CO₂): Single beam, dual wavelength NDIR; Humidity: Capacitive polymer; Temperature: 10K Ω thermistor.
Range: CO₂: 0 to 2000 or 5000 PPM CO₂ (depending on model); Humidity: 0 to 100% RH; Temperature: 32 to 122°F (0 to 50°C).
Accuracy: CO₂: ±40 PPM ±3% of reading; RH: ±2% (10 to 90% RH); Temperature: ±1°C @ 25°C.
Temperature Dependence (CO₂): ±8 PPM / °C at 1100 PPM.
Non-Linearity (CO₂): 16 PPM.
Pressure Dependence (CO₂): 0.13% of reading per mm of Hg.
Response Time (CO₂): 2 min= for 99% step change.
Temperature Limits: 32 to 122°F (0 to 50°C).
Humidity Limits: 10 to 95% RH (non-condensing).
Power Requirements: 10-42 VDC / 10-30 VAC.
Power Consumption: Average: 0.5 watts; Peak: 1.2 watts.
Output: 2-wire RS-485, Modbus® RTU or BACnet MS/TP communication protocol.
Weight: 4.4 oz (125 g).
Enclosure Rating: IP20.
Agency Approvals: BTL, CE.

ACCESSORIES	
Model	Description
GCK-200CO-2000CO2	Calibration gas kit includes a 99.99% nitrogen gas cylinder for calibrating the zero point and a 200 PPM CO / 2000 PPM CO ₂ gas cylinder for calibrating the span point on Dwyer's gas sensing transmitters
A-449	Remote LCD display allows remote indication of select Dwyer® wall mount transmitters for validation or certification purposes
A-CDT-KIT	Accessory kit including terminal block and power supply



GCK-200CO-2000CO2

A-449

LEED® is a registered trademark of the U.S. Green Building Council.
Modbus® is a registered trademark of Schneider Automation, Inc.

CARBON DIOXIDE/RH/TEMPERATURE TRANSMITTERS

NDIR CO₂ Sensor, Universal CO₂/RH Outputs, Optional Relay

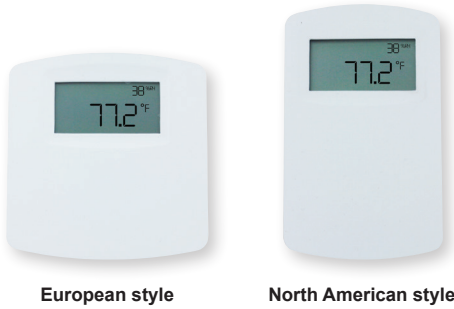

European style

North American style



Duct

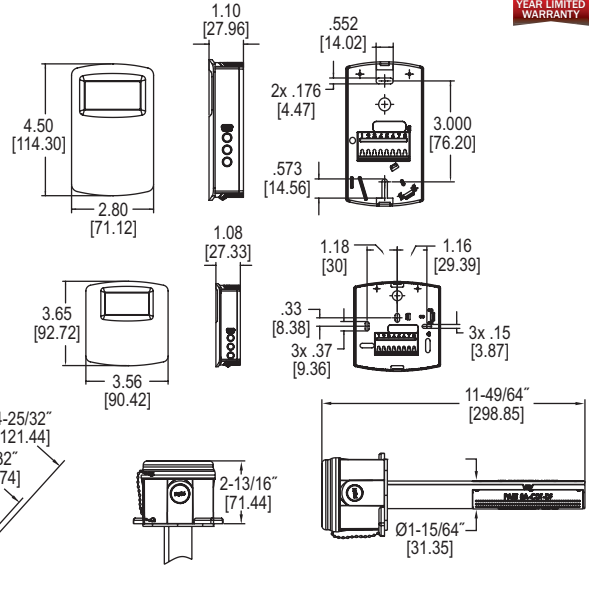

The **Series CDTR Carbon Dioxide, Relative Humidity and Temperature Transmitters** reduce the number of sensors mounted on a wall or in a duct. By combining CO₂, RH, and temperature in one device, system integrators are able to reduce installation time while lowering material cost at the same time.

Like our popular Series CDT Carbon Dioxide Transmitter, a single beam dual wavelength non-dispersive infrared (NDIR) sensor is used to automatically correct the measurement in both occupied* and unoccupied buildings against light source aging effects. In order to achieve the best possible accuracy, the Series CDTR also includes digital barometric pressure adjustment and the ability to field calibrate the sensor.

Universal outputs for both carbon dioxide and relative humidity allow users to select the transmitter output to be 4-20 mA, 0-5 VDC, or 0-10 VDC to work with virtually any building management controller. Additionally, passive thermistor or RTD sensor can be ordered for a temperature output.

For applications that require visual indication, the wall mount configurations of the Series CDTR can be ordered with an integral LCD display. The display can be configured to display temperature only, relative humidity only, CO₂ only, CO₂ and humidity, or CO₂ and temperature. Push-buttons are standard on all configurations of the transmitters for access to the menu structure. To prevent tampering, the action of the buttons can be locked out using an internal jumper selection.

FEATURES/BENEFITS

- Digital Intelligence Temperature Compensation Algorithm (DITCA™) eliminates error due to the self heating effects of wall mount combination devices.
- Single beam dual wavelength NDIR CO₂ sensor
- Replaceable humidity/temperature sensors
- Physical hardware lockout
- Service display tool available for duct mount and wall mount units without an LCD
- Relay output option

APPLICATIONS

- Demand control ventilation in schools, office buildings, hospitals, and other indoor environments
- LEED® certification

*For buildings occupied 24 hours per day, it is recommended that calibration be verified every 6 to 12 months depending on application.

SPECIFICATIONS

Range: CO₂: 0 to 2000 or 0 to 5000 PPM (depending on model); Relative humidity: 0 to 100%; Temperature: 32 to 122°F (0 to 50°C).
Accuracy: ±40 PPM + 3% of reading (CO₂); ±2% (RH).
Temperature Dependence: ±8 PPM / °C at 1100 PPM.
Non-Linearity: 16 PPM.
Pressure Dependence: 0.13% of reading per mm of Hg.
Response Time: 2 minutes for 99% step change.
Temperature Limits: 32 to 122°F (0 to 50°C).
Duct Air Velocity Range: 0-4000 FPM (20.32 m/s)
Humidity Limits: 10 to 95% RH (non-condensing).
Power Requirements: 16-35 VDC / 19-28 VAC.
Power Consumption: Average: 2 watts; Peak: 3.75 watts.
Sensor: Single beam, dual wavelength NDIR.
Output: Current: 4-20 mA (max 500 Ω); Voltage: 0-5 VDC or 0-10 VDC (min 500 Ω); Relay: SPST NO 2 A @ 30 VDC; RTD or thermistor per r-t curves (depending on model).
Weight: 5.6 oz (158.8 g).
Enclosure Rating: Duct mount: NEMA 4X (IP66) for housing only; Wall mount: IP20.
Agency Approvals: CE.

MODEL CHART

Example	CDTR	-2	N	4	A	4	-LCD	CDTR-2N4A4-LCD
Series	CDTR							Carbon dioxide/RH/temperature transmitter
Range		2 5						0 to 2000 PPM CO ₂ range 0 to 5000 PPM CO ₂ range
Configuration			N E D					North American style wall mount European style wall mount Duct mount
CO ₂ Output				4				4-20 mA / 0 to (5 or 10) VDC
Temperature Output					0 A B C D E F			None 10K Ω NTC thermistor type III 10K Ω NTC thermistor type II 3K Ω NTC thermistor Pt100 Ω RTD Pt1000 Ω RTD 20K Ω NTC thermistor
RH Output						4		4-20 mA / 0 to (5 or 10) VDC
Options							FC LCD RLY NBC	Factory calibration certificate LCD display (wall only) Relay No buttons (wall only)

ACCESSORIES

Model	Description
GCK-200CO-2000CO2	Calibration gas kit includes a 99.99% nitrogen gas cylinder for calibrating the zero point and a 200 PPM CO / 2000 PPM CO ₂ gas cylinder for calibrating the span point on Dwyer's gas sensing transmitters
A-449	Remote LCD display allows remote indication of select Dwyer® wall mount transmitters for validation or certification purposes
A-449A	Remote LCD display with buttons allows remote indication and calibration of select Dwyer® wall mount transmitters for validation and certification purposes
A-CDT-KIT	Accessory kit including terminal block and power supply

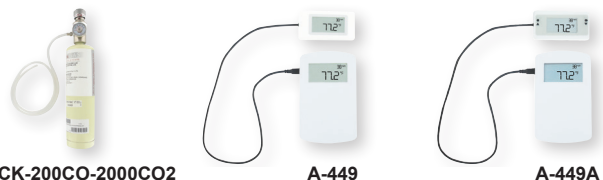

LEED® is a registered trademark of the U.S. Green Building Council.

CARBON DIOXIDE/VOLATILE ORGANIC COMPOUND TRANSMITTERS

Simultaneously Outputs Both CO₂ / VOC



North American style

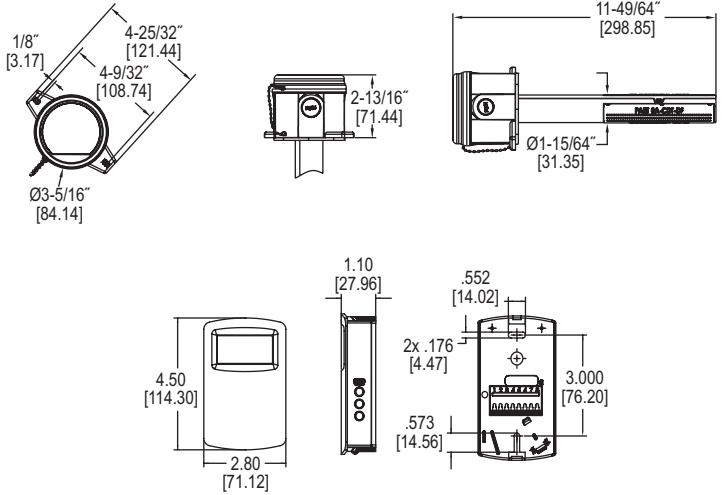

The Series CDTV Carbon Dioxide/Volatile Organic Compound Transmitters reduce energy cost in buildings by lowering the amount of conditioned air based on the occupancy of the space. By sensing both CO₂ and VOC, the transmitter can detect fumes that may need to be exhausted during lower occupancy periods.

FEATURES/BENEFITS

- Combination VOC and CO₂ outputs reduce labor and material costs
- Single beam dual wavelength NDIR CO₂ sensor allows for use in spaces that may be occupied 24 hours a day
- VOC output is correlated to be equivalent to CO₂ measurements
- Ventilate using ASHRAE's occupancy-based VRP Algorithm

APPLICATIONS

- HVAC applications in hospitals, schools, and commercial buildings
- Demand control ventilation
- Odor control
- Waiting rooms or other spaces that may be occupied 24 hours a day

SPECIFICATIONS

Range: CO₂: 0 to 2000 or 0 to 5000 PPM (depending on model); VOC: 0 to 2000 PPM CO₂ equivalent.
Accuracy: CO₂: ±40 PPM ±3% of reading.
Temperature Dependence: ±8 PPM / °C at 1100 PPM.
Non-Linearity: CO₂: 16 PPM.
Pressure Dependence: CO₂: 0.13% of reading per mm of Hg.
Response Time: CO₂: 2 minutes for 99% step change; VOC: 5 minutes.
Temperature Limits: 32 to 122°F (0 to 50°C).
Duct Air Velocity Range: 0-4000 FPM (20.32 m/s).
Power Requirements: 16-35 VDC / 19-28 VAC.
Power Consumption: Average: 2 watts; Peak: 3.75 watts.
Sensor: CO₂: Single-beam, dual-wavelength NDIR; VOC: MEMS metal oxide semiconductor.
Output: Current: 0-20 mA, 4-20 mA, 0-10 mA, or 2-10 mA (depending on selection jumper, max 500 Ω); Voltage: 0-10 VDC, 2-10 VDC, 0-5 VDC, or 1-5 VDC (depending on selection jumper, min 500 Ω); Relay: SPST NO 2A @ 30 VDC.
Weight: 5.6 oz (158.8 g).
Enclosure Rating: Duct mount: NEMA 4X (IP66) for housing only; Wall mount: IP20.
Agency Approvals: CE.

MODEL CHART							
Example	CDTV	-2	D	4	A	4	-RLY CDTV-2D4A4-RLY
Series	CDTV						Carbon dioxide/VOC transmitter
Range		2 5					0 to 2000 PPM CO ₂ range 0 to 5000 PPM CO ₂ range
Configuration			D N				Duct North American style wall mount
CO ₂ Output				4			4-20 mA / 0 to (5 or 10) VDC
Temperature Output					0 A B C D E F		None 10 KΩ NTC thermistor type III 10 KΩ NTC thermistor type II 3 KΩ NTC thermistor Pt100 Ω RTD Pt1000 Ω RTD 20 KΩ NTC thermistor
VOC Output						4	4-20 mA / 0 to (5 or 10) VDC
Options							RLY Relay FC Factory calibration certificate LCD LCD display (wall only) COC Certificate of calibration

CARBON DIOXIDE TRANSMITTER

NDIR CO₂ Sensor with Universal Outputs in an Industrial Housing

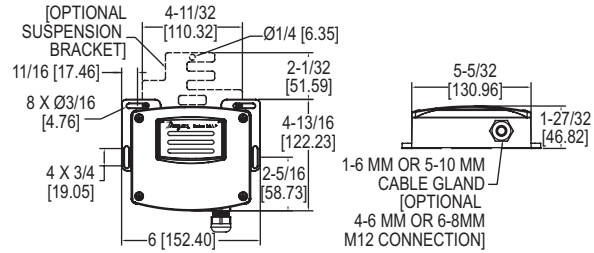

The **Series CDWP Carbon Dioxide Transmitter** accurately monitors the CO₂ concentration in industrial and indoor environments to help achieve energy savings. For increased sensor life and accuracy, a single-beam dual-wavelength non-dispersive infrared (NDIR) sensor is used to eliminate light source aging effects. This sensing technology provides the highest level of accuracy compared to Automatic Baseline Correction methods, which can unintentionally shift the calibration based on CO₂ levels and barometric pressure conditions.

FEATURES/BENEFITS

- IP54 aluminum housing
- Gray finish tested to withstand 168 hour salt spray test
- Single-beam dual-wavelength sensor automatically corrects for aging effects
- Measures unfiltered light intensity directly and eliminates error from incorrect assumptions of gas concentration in theoretical logic assumption methods
- Universal outputs to work with any building management system

APPLICATIONS

- Animal husbandry
- Mechanical room
- CO₂ refrigeration monitoring
- Greenhouses

SPECIFICATIONS

Sensor: Single beam, dual-wavelength NDIR.
Range: CO₂: 0 to 2000, 0 to 5000, or 0 to 10000 PPM (depending on model).
Accuracy: CO₂: ± 40 PPM ±3% of reading.
Temperature Dependence: ±8 PPM/°C at 1100 PPM.
Non-Linearity: 16 PPM.
Pressure Dependence: 0.13% of reading per mm of Hg.
Response Time: 300 s (τ₆₃).
Temperature Limits: 32 to 122°F (0 to 50°C).
Humidity Limits: 10 to 95% RH (non-condensing).
Power Requirements: 16-35 VDC or 19-28 VAC.
Power Consumption: Average: 2 w; Peak: 3.75 w.
Output: Current: 4-20 mA (max. 500 Ω); Voltage: 0-5 VDC or 0-10 VDC (min. 500 Ω).
Enclosure Rating: IP54.
Mounting Orientation: Vertically, with electrical connections points downward.
Weight: 26.24 oz (744 g).
Agency Approvals: CE.

MODEL CHART						
Example	CDWP	-05	W	-M4	-FC	CDWP-05W-M4
Series	CDWP					Carbon dioxide transmitter
Range		02 05 10				2000 PPM 5000 PPM 10000 PPM
Mounting			W H			Wall mount Suspended mount
Electrical Connection				C1 C5 M4 M6		Cable gland 1 to 6 mm cable Cable gland 5 to 10 mm cable M12 connection 4 to 6 mm cable M12 connection 6 to 8 mm cable
Option					FC	Factory calibration certificate

ACCESSORIES

Model	Description
A-CDWP-L	Replacement lid with filter material
A-CDWP-H	Suspended mount bracket

MODEL OSC-200 & OSW-100

OCCUPANCY SENSORS

Wide Viewing Angle, Easy To Install



OSC-200

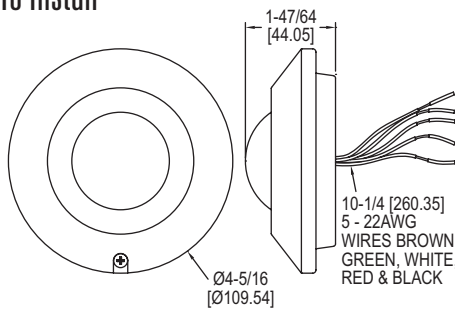

OSW-100

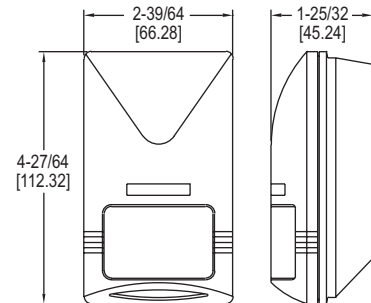

The **Model OSC-200 Occupancy Sensors** help to automate building control systems. A spherical Fresnel lens provides a 360° detection zone with the use of infrared technology.

The **Model OSW-100 Occupancy Sensor** is an infrared sensor designed to help automate building control systems. The Model OSW-100 has a wide 110° viewing angle to capture movement up to 49.2' (15 m) away.

FEATURES/BENEFITS

- Delay processor suppresses switch activation during momentary occupancy

APPLICATIONS

- Lighting control
- Building energy conservation

MODEL CHART	
Model	Description
OSC-200	Omnidirectional occupancy sensor
OSW-100	Wall mount occupancy sensor

SPECIFICATIONS

Infrared Sensor: Dual element.
Range: OSC-200: 34.4' (10.5 m) diameter at 13.8' (4.2 m) mount height; OSW-100: 49.2' (15 m).
Detectable Speed: 0.33 to 9.8 ft/s (0.1 to 3.0 m/s).
Control Output Rating: SPDT, 0.2 A @ 30 VDC.
Ambient Operating Temperature: -4 to 140°F (-20 to 60°C).
Power Consumption: Standby: 5 mA; Operating: 18 mA.
Mounting Height: OSC-200: 7.9 to 13.8' (2.4 to 4.2 m); OSW-100: 5.9 to 11.8' (1.8 to 3.6 m).
Power Requirements: 22-26 VAC/DC.
Weight: OSC-200: 2.4 oz (68 g); OSW-100: 3.2 oz (90.7 g).
Agency Approvals: CE.

CARBON MONOXIDE/NITROGEN DIOXIDE GAS TRANSMITTERS

High Accuracy Electrochemical Sensor, Universal Output or BACnet or Modbus® Communication Protocol Options



Wall mount with LCD



Wall mount without LCD



Duct mount

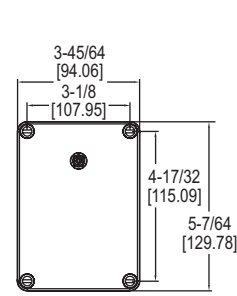

Wall mount

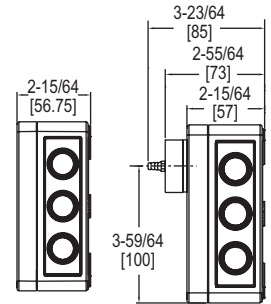

Duct mount



The Series GSTA & GSTC Carbon Monoxide/Nitrogen Dioxide Gas Transmitters monitor gas concentrations in mechanical rooms, underground parking garages and loading docks. The carbon monoxide transmitter is used to measure the exhaust of gasoline engines, while the nitrogen dioxide transmitter is used for diesel engines. The Series GSTA features field selectable current and voltage outputs while the Series GSTC features BACnet or Modbus® communication protocol, allowing gas sensing solutions that can be used with almost any building management controller.

FEATURES/BENEFITS

- Industrial grade replaceable CO or NO₂ sensors
- Field selectable current or voltage output on GSTA models, and field selectable BACnet or Modbus® communication on GSTC models
- Integral LCD display option
- Service display tool for set-up and calibration of models without a LCD

APPLICATIONS

- Garage or loading dock ventilation
- Mechanical room monitoring

MODEL CHART			
Example	GSTA	-C	GSTA-C
Series	GSTA		Field selectable analog outputs
	GSTC		Field selectable BACnet or Modbus®
Gas Sensed		C	CO, carbon monoxide
		N	NO ₂ , nitrogen dioxide
Options		-	Wall mount without LCD
		D	Duct mount
		LCD	Wall mount with LCD

ACCESSORIES	
Model	Description
GCK-200CO-2000CO2	Calibration gas
A-449	Remote LCD display
A-505	CO replacement sensor
A-506	NO ₂ replacement sensor
A-507	Calibration adapter

SPECIFICATIONS

Sensor: Field replaceable electrochemical, 4 years typical lifespan.
Range: CO: 0 to 500 PPM, NO₂: 10 PPM.
Output Drift: <5% per year in air.
Coverage Area: 5000 to 7500 sq ft typical.
Accuracy: CO: 2% FS, NO₂: 3% FS, at the time of calibration.
Resolution: CO: 1 PPM; NO₂: 0.1 PPM.
Temperature Limits: -4 to 122°F (-20 to 50°C).
Storage Temperature: For best sensor life, 32 to 68°F (0 to 20°C).
Humidity Limits: 15 to 90% RH constant; 0 to 99% RH intermittent.
Response Time: <45 s to 90% CO, <25 s to 90% NO₂.
Span and Zero Adjustment: Via push-button, using optional A-449 display. Zero only via BACnet or Modbus® communication protocol.
Housing: UV resistant glass filled polycarbonate.
Output Signals: GSTA: Switch selectable 4-20 mA (loop powered), 0-5 V @ 5 mA, or 0-10 V @ 5 mA; Switch selectable 0-5 V / 1-5 V and 0-10 V / 2-10 V; Switch selectable normal or reverse output; GSTC: BACnet MS/TP, Modbus® RTU, or Modbus® ASCII (switch selectable) communication protocol.
Power Requirements: GSTA: Current output: 10-35 VDC, Voltage output: 15-35 VDC or 15-29 VAC; GSTC: 10-36 VDC or isolated 21.6-33 VAC.
Electrical Connection: Removable terminal block, knock outs for conduit fitting.
Calibration: Via pushbuttons using A-449 auxiliary display. Span gas concentration is field selectable.
Enclosure Rating: IP64.
Weight: 1 lb (0.45 kg).
Agency Approvals: CE.



GCK-200CO-2000CO2



A-449



A-505



A-506



A-507

CARBON MONOXIDE TRANSMITTERS

Current/Voltage Selectable Output, 200 PPM Range

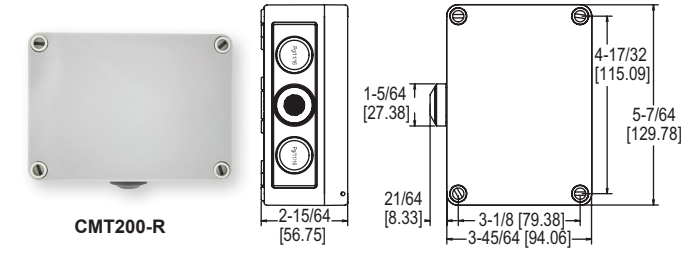
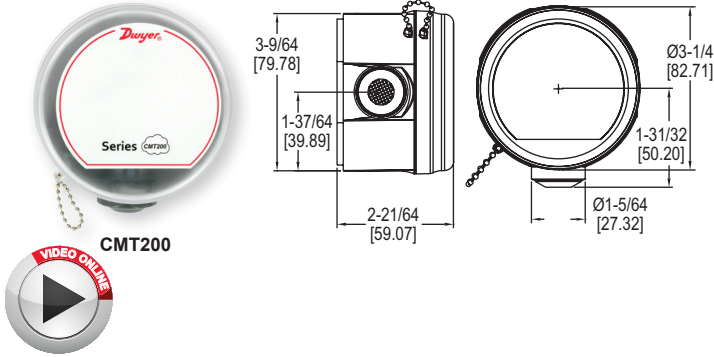

The Series CMT200 Carbon Monoxide Transmitters provides a field selectable current or voltage output that is proportional to the gas concentration in underground parking garages, vehicle maintenance facilities, or mechanical rooms.

FEATURES/BENEFITS

- Field selectable current or voltage outputs
- Replaceable sensor
- Field calibration kits

APPLICATIONS

- Garage ventilation
- Mechanical room monitoring

MODEL CHART	
Model	Description
CMT200	Carbon monoxide transmitter
CMT200-R	Carbon monoxide transmitter with rugged housing

ACCESSORIES	
Model	Description
GCK-200CO-2000CO2	Calibration gas
A-505	Replacement Carbon Monoxide Sensor
A-507A	Calibration adaptor

SPECIFICATIONS

Sensor: Field replaceable electrochemical, 4 year typical lifespan.
Range: 0 to 200 PPM.
Coverage Area: 5000 to 7000 sq. ft. typical.
Accuracy: ±2% FS at the time of calibration.
Output Drift: <5% per year in air.
Temperature Limits: -4 to 122°F (-20 to 50°C).
Storage Temperature: For best sensor life, 32 to 68°F (0 to 20°C).
Humidity Limits: 15 to 90% RH constant; 0 to 99% RH intermittent.
Response Time: <45 s to 90% of final value.
Calibration: 15 turn span and zero adjustment potentiometers.
Housing: UV resistant polycarbonate.
Output: Jumper selectable 4-20 mA (loop powered) or 2-10 V (load must be >50 KΩ).
Power Requirements: Current output: 18-28 VDC; Voltage output: 18-28 VDC/VAC, reverse polarity protected.
Electrical Connection: Removable terminal block, includes two PG11 and one PG 16 knockouts for conduit fitting.
Weight: 0.28 lb (0.11 kg).
Agency Approvals: CE.

CARBON MONOXIDE TRANSMITTER AND SWITCH

Current/Voltage Selectable Output, Jumper Selectable SPDT Relay Contact



The Series CMS300 Carbon Monoxide Transmitter and Switch provides a field selectable current or voltage output that is proportional to the carbon monoxide concentration in underground parking garages, vehicle maintenance facilities, or mechanical rooms. An integral relay can be used for alarm conditions and is configured with preset jumper selectable ranges of 25, 60, or 150 PPM. Field calibration can be done by using Model GCK-200CO-2000CO2 calibration gas, Model A-507 calibration adaptor, and the on board zero and span potentiometers.

FEATURES/BENEFITS

- Field selectable current or voltage analog outputs
- Integral SPDT relay contact for low or high alarm
- Jumper selectable alarm set points of 25, 60, or 150 PPM
- UL recognized carbon monoxide sensing element
- Field calibration kits

APPLICATIONS

- Garage or loading dock ventilation
- Vehicle maintenance facilities
- Mechanical room monitoring

SPECIFICATIONS

Sensor: Electrochemical, 5 years typical lifespan.
Range: 0-300 PPM.
Output Drift: <5% per year in air.
Temperature Effect: ±2% over range.
Coverage Area: 7,500 ft² (700 m²) or 50 ft (15 m) radius.
Accuracy: ±5 PPM or 5% of reading for 0-300 PPM (whichever is greater).
Resolution: 1 PPM.
Temperature Range: -4 to 122°F (-20 to 50°C).
Storage Temperature: For best sensor life, 32°F to 68°F (0 to 20°C).
Humidity Range: 15-90% RH constant; 0-99% RH intermittent.
Response Time: <45 seconds to 90% of final value.
Calibration: 15 turn span and zero adjustment potentiometers.
Housing: UV resistant glass filled polycarbonate.
Analog Output: Jumper selectable 4-20 mA (loop powered) or 2-10 V (max. load 2K Ω).
Enclosure Rating: IP64.
Weight: 1 lb (0.45 kg).
Switch Type: Single-pole double-throw (SPDT).
Electrical Rating: 30 VAC/VDC. N/O = 5 A. N/C = 3 A.
Set Point: Jumper selectable 25, 60, or 150 PPM.
Set Point Differential/Hysteresis: 3% of scale.
Relay Action: Factory set for direct acting.
Agency Approvals: Sensor is UL recognized component for ANSI/UL-2034, UL-2075, E340403, CE.

MODEL CHART	
Model	Description
CMS300	Carbon monoxide transmitter and switch

ACCESSORIES	
Model	Description
GCK-200CO-2000CO2	Calibration gas
A-507	Calibration adaptor



SERIES SL-2000

DUCT SMOKE DETECTOR

Early Smoke Detection in HVAC Systems

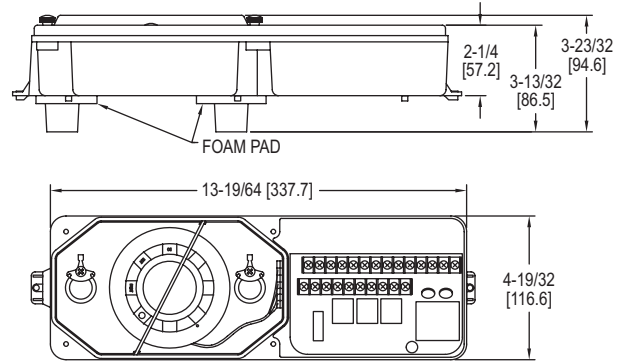
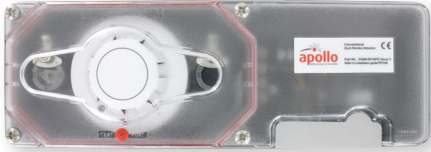

The **Series SL-2000 Duct Smoke Detector** is crucial for early detection of smoke and products of combustion present within HVAC ductwork. This series can be utilized in many different types of applications including commercial, industrial, and residential. The unit is designed to not only alarm when smoke is detected, but will also utilize relays to disable fans and blowers. The series comes complete with technician friendly “No-Tools Required” features to make installation and servicing simple and efficient.

FEATURES/BENEFITS

- Operates in air speeds of 100 to 4000 ft/min
- Transparent cover to view detector head LED
- Patented “No-Tools Required” front or rear loading and removing sampling/exhaust tubes
- Integrated smoke test port

APPLICATIONS

- Early smoke detection in ductwork
- Commercial/Industrial/Residential HVAC
- BAS automation

SPECIFICATIONS

Sensor Type: Photoelectric or Ionization.
Air Velocity Range: 100 to 4000 ft/min.
Ambient Temperature: SL-2000-N: 32°F to 158°F (0°C to 70°C); SL-2000-P: 32°F to 140°F (0°C to 60°C).
Humidity Limits: 85 ±5 % RH (@32 ±2°C; 86 ±3.6°F) Non-condensing/Non-freezing.
Power Requirements: Standby: 230 VAC (12 mA), 115 VAC (22 mA), 24 VAC (55 mA), or 24 VDC (14 mA); Alarm: 230 VAC (18 mA), 115 VAC (32mA), 24 VAC (190 mA), or 24 VDC (68 mA).
Electrical Rating: Alarm contacts: 2 sets form “C” rated at 10 A resistive @ 115 VAC and 1 set form “A” rated at 2 A; Trouble contacts: 1 set form “C” rated at 10 A @ 115 VAC.
Electrical Connections: Screw terminals.
Enclosure: Grey plastic backbox, clear plastic cover (Makrolon 94V-0).
Enclosure Rating: SL-2000: NEMA 1; WP-2000: NEMA 3R.
Radioactive Element: For SL-2000-N (Ionization) americium 241; 0.9 Micro-curie; Do not expose to corrosive atmospheres.
Weight: 2.5 lbs.
Approvals: cULus (UL 268A) file # S2829, CSFM listed (3240-1004:105), MEA accepted (73-92-E; VOL. 27).

MODEL CHART	
Model	Sensor Type
SL-2000-N	Conventional, 4 wire, universal voltage, ionization duct smoke detector
SL-2000-P	Conventional, 4 wire, universal voltage, photoelectric duct smoke detector

ACCESSORIES	
Model	Sensor Type
FAST TUBE	Sectional, polycarbonate sampling tube, bag of (3) 24” tubes
TG-2500	Test gas for SL-2000 models
WP-2000	Weatherproof enclosure for SL-2000 models
55000-225APO	Ionization replacement sensor for SL-2000-N
55000-328APO	Photoelectric replacement sensor for SL-2000-P

AIR VELOCITY TRANSMITTERS

3% and 5% Models, Optional BACnet or Modbus® Communication Protocols

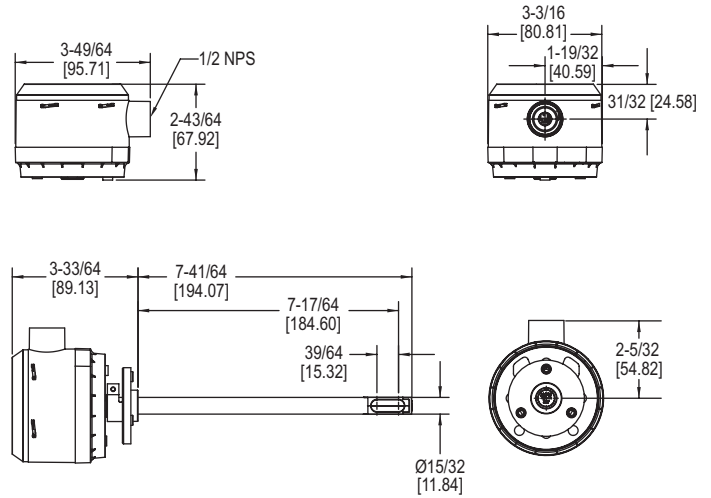

The **Series AVUL Air Velocity Transmitters** quickly and accurately measures air velocity or volumetric flow in imperial or metric units. Simultaneous current and voltage outputs on all models provide universal inputs to monitoring equipment while the output range, units, and 0 to 5/10 VDC output can be configured via local DIP switches. The optional integral display, or the portable remote display tool, provide a convenient way to locally monitor process values and configure the unit. Models are available in 3% and 5% accuracy models to suit a variety of needs, and the optional BACnet MS/TP or Modbus® RTU/ASCII communication protocol allows units to be daisy-chained while providing access to all of the velocity and flow data, as well as additional information such as air temperature.

FEATURES/BENEFITS

- Sensing elements have been coated with an engineered conformal coating to ensure durability and longevity
- Field selectable ranges can be quickly configured without power to the unit

APPLICATIONS

- VAV systems
- Building ducts

MODEL CHART	
Model	Description
AVUL-5DA1	Air velocity transmitter, 5% accuracy, duct mount, Universal current/voltage outputs
AVUL-5DA1-LCD	Air velocity transmitter, 5% accuracy, duct mount, Universal current/voltage outputs, with LCD
AVUL-5DB1	Air velocity transmitter, 5% accuracy, duct mount, BACnet communications
AVUL-5DB1-LCD	Air velocity transmitter, 5% accuracy, duct mount, BACnet communications, with LCD
AVUL-5DM1	Air velocity transmitter, 5% accuracy, duct mount, Modbus® communications
AVUL-5DM1-LCD	Air velocity transmitter, 5% accuracy, duct mount, Modbus® communications, with LCD
AVUL-3DA1	Air velocity transmitter, 3% accuracy, duct mount, Universal current/voltage outputs
AVUL-3DA1-LCD	Air velocity transmitter, 3% accuracy, duct mount, Universal current/voltage outputs, with LCD
AVUL-3DB1	Air velocity transmitter, 3% accuracy, duct mount, BACnet communications
AVUL-3DB1-LCD	Air velocity transmitter, 3% accuracy, duct mount, BACnet communications, with LCD
AVUL-3DM1	Air velocity transmitter, 3% accuracy, duct mount, Modbus® communications
AVUL-3DM1-LCD	Air velocity transmitter, 3% accuracy, duct mount, Modbus® communications, with LCD

SPECIFICATIONS

Service: Clean air and non-combustible, compatible gases.
Wetted Materials: Consult factory.
Range: 1000, 2000, 3000, 4000 FPM (5, 10, 15, 20 m/s); Field selectable.
Accuracy: ±(5% of reading + 0.2 m/s) or ±(3% of reading + 0.2 m/s) @ standard conditions, depending on model.
Temperature Limits: 32 to 122°F (0 to 50°C).
Power Requirements: 24 VDC ±20% or 24 VAC ±20%.
Humidity Limits: 5 to 95% RH, non-condensing.
Output Signals: 4-20 mA, 0-5 VDC, 0-10 VDC.
Response Time (90%): 10 s, typical.
Zero & Span Adjustments: Digital push-buttons.
Output Load Resistance: Current output: 0 to 1100 Ω max.; Voltage output: Minimum load resistance 1 k Ω.
Current Consumption: 60 mA max.
Display (optional): 5 digit LCD.
Electrical Connections (Analog): Power and output: four wire removable European style terminal block for 16 to 26 AWG.
Communication (optional): Connections: BACnet MS/TP or Modbus® RTU/ASCII: three wire removable European style terminal block for 16 to 26 AWG; Supported baud rates: 9600, 19200, 38400, 57600, 76800, 115200.
Device Load: 1/8th unit load.
Electrical Entry: 1/2" NPS thread. Accessory (A-151): Cable gland for 5 to 10 mm diameter cable.
Enclosure Rating: NEMA 4X (IP66).
Mounting Orientation: Flow direction must be parallel to the sensor tip.
Weight: 6.0 oz (160 g).
Agency Approval: BTL, CE.

ACCESSORIES

Model	Description
A-151	Cable gland for 5 to 10 mm diameter cable
A-435-A	Remote display tool
A-AVUL-LCD	Field upgradeable display
A-AVUL-MTG	Replacement mounting flange
SCD-PS	100-240 VAC/VDC to 24 VDC power supply

AIR VELOCITY TRANSMITTER

1% and 2% Models, Optional BACnet MS/TP or Modbus®

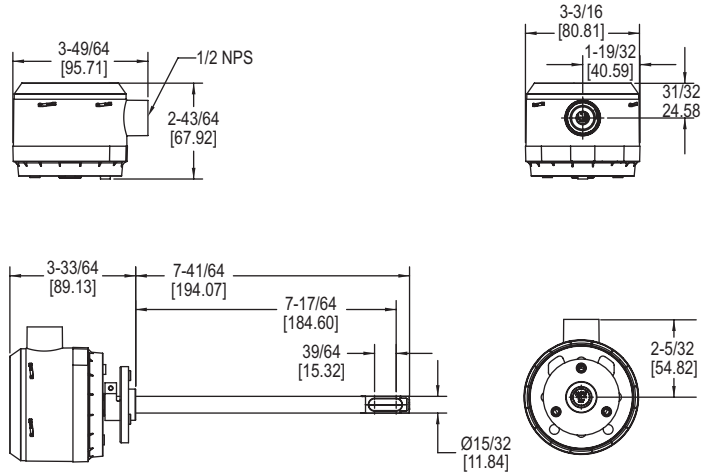

The **Series AVLV Air Velocity Transmitter** quickly and accurately measures air velocity or volumetric flow in imperial or metric units. Simultaneous current and voltage outputs on all models provide universal inputs to monitoring equipment while the output range, units, and 0-5/10 VDC output can be configured via local DIP switches. The optional integral display, or the portable remote tool, provide a convenient way to local monitor process values and configure the unit.

Models are available in 1% and 2% accuracy models and low velocity ranges to suit a variety of needs, and the optional BACnet MS/TP or Modbus® RTU/ASCII communication protocol allows units to be daisy-chained while providing access to all of the velocity and flow data, as well as additional information such as air temperature. The lower ranges in these high accuracy units allow for applications in quality intensive environments, such as the pharmaceutical industry.

FEATURES/BENEFITS

- Sensing elements have been coated with an engineered conformal coating to ensure durability and longevity
- Field selectable ranges can be quickly configured without power to the unit

APPLICATIONS

- VAV systems
- Building ducts
- Clean room systems

SPECIFICATIONS	
Service:	Clean air and non-combustible, compatible gases.
Wetted Materials:	Consult factory.
Range:	100, 200, 300, 400 FPM (0.5, 1, 1.5, 2 m/s); field selectable.
Accuracy:	See chart.
Temperature Limits:	32 to 122°F (0 to 50°C).
Power Requirements:	24 VDC ±20% or 24 VAC ±20%.
Humidity Limits:	5 to 95% RH, non-condensing.
Output Signals:	4-20 mA, 0-5 VDC, 0-10 VDC.
Response Time (90%):	4 s, typical; 1 s at constant temperature.
Zero & Span Adjustments:	Digital push buttons.
Output Load Resistance:	Current output: 0 to 1100 Ω max.; Voltage output: Minimum load resistance 1 kΩ.
Current Consumption:	60 mA max.
Display:	5 digit LCD (optional).
Electrical Connections:	Analog: Power and output: four wire removable European style terminal block for 16 to 26 AWG; Communication: Connections: BACnet MS/TP or Modbus® RTU/ASCII: three wire removable European style terminal block for 16 to 26 AWG.
Supported Communication Baud Rates:	9600, 19200, 38400, 57600, 76800, 115200 (optional).
Device Load:	1/8 unit load.
Electrical Entry:	1/2" NPS thread; Accessory: Cable gland for 5 to 10 mm diameter cable, A-151.
Enclosure Rating:	NEMA 4X (IP66).
Mounting Orientation:	Flow direction must be parallel to the sensor tip.
Weight:	6.0 oz (160 g).
Agency Approval:	BTL, CE.

MODEL CHART						
Example	AVLV	-2	D	A1	-LCD	AVLV-2DA1-LCD
Model	AVLV					Air velocity transmitter
Accuracy		2				± (2% of reading + 0.06 m/s) ± (1% of reading + 0.06 m/s)
Mounting			D			Duct mount
Output				A1		Analog universal (0-5 VDC, 0-10 VDC, 4-20 mA)
				B1		Analog + BACnet MS/TP
				M1		Analog +Modbus® RTU/ASCII
Options					LCD	LCD display
					FC	Factory calibration certificate
					NIST	NIST certificate
					GLD	Electrical cable gland

ACCURACY CHART	
Velocity Range	Accuracy Rating*
20 to 100 FPM (0.15 to 0.5 m/s)	± (2% of reading + 0.04 m/s [7.9 FPM]) ± (1% of reading + 0.04 m/s [7.9 FPM])
20 to 200 FPM (0.15 to 1.0 m/s)	± (2% of reading + 0.04 m/s [7.9 FPM]) ± (1% of reading + 0.04 m/s [7.9 FPM])
20 to 300 FPM (0.15 to 1.5 m/s)	± (2% of reading + 0.05 m/s [9.8 FPM]) ± (1% of reading + 0.05 m/s [9.8 FPM])
20 to 400 FPM (0.15 to 2.0 m/s)	± (2% of reading + 0.06 m/s [11.8 FPM]) ± (1% of reading + 0.06 m/s [11.8 FPM])

*Accuracy dependent on model selected when ordering.

PENCIL STYLE AIR VELOCITY TRANSMITTER

3% and 5% Models, Optional BACnet Communication Protocols

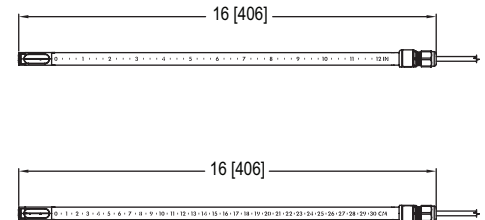
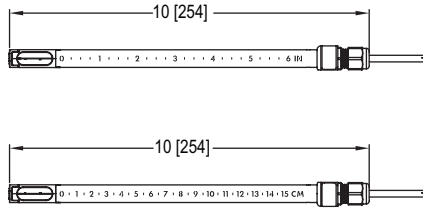
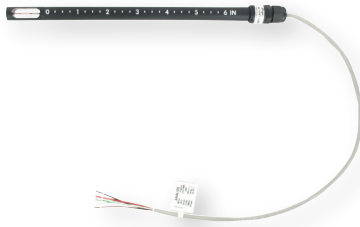

6" probe length

12" probe length

The **Series AVPT Pencil Style Air Velocity Transmitter** uses thermal anemometer technology to provide high accuracy and stable air velocity measurements in imperial and metric units. The Series AVPT can be configured with either a voltage output or BACnet MS/TP communication to provide universal inputs to a variety of monitoring equipment. Models are available with fixed cable lengths of 20 or 78 inches with flying leads or a 5-pin M12 connector on a 24 inch cable. Probes are available in lengths of 6 or 12 inches. A mounting flange included with the product provides the ability to vary insertion depth.

Models are available in 3% or 5% accuracy to suit a variety of applications, while the optional BACnet MS/TP communication protocol allows units to be daisy-chained to provide access to all of the velocity and temperature measurements.

FEATURES/BENEFITS

- Sensing elements have been coated with an engineered conformal coating to ensure durability and longevity
- Varying lengths for easy installation
- Functionality at temperatures below freezing

APPLICATIONS

- VAV systems
- Building ducts

SPECIFICATIONS

Service: Clean air.
Ranges: 1000, 2000, 3000, or 4000 FPM (5, 10, 15, or 20 m/s); Model specific.
Accuracy: Standard: ±(5% reading +40 FPM); High accuracy: ±(3% reading +40 FPM); Model specific.
Power Requirements: 24 VAC/VDC ±20%.
Current Consumption: < 50 mA.
Outputs: Analog: 0-10 V (0-5 V configurable).
BACnet MS/TP: Selectable at time of order.
Supported Baud Rate: 9600, 19200, 38400, 57600, 76800, and 115200.
Voltage Output Load Resistance: 10k Ω minimum (10 V output with AC supply); 1k Ω minimum all other conditions.
Electrical Connection: Cable: Plenum rated cable with 22 AWG conductors.
5-Conductor Cable whip: 20" (0.5 m) or 78" (2 m).
5-pin M-12: 24" (0.6 m); model specific.
Response Time (90%): 4 s, typical.
Operational Temperature Limits: -4 to 140 °F (-20 to 60 °C).
Storage Temperature Limits: -40 to 140°F (-40 to 60°C).
Probe Length: 6" or 12"; model specific.
Enclosure Rating: NEMA 3.
Mounting Orientation: Flow direction must be parallel to the sensor tip; See Installation section for details.
Weight: 1.4 oz (40 g); based on M12 connection with 12" probe length.
Agency Approvals: CE, RCM, BTL, UL plenum rated (UL tested).

MODEL CHART									
Example	AVPT	-S	03	C1	A	06	-127	-FC	AVPT-S03C1A06-127-FC
Series	AVPT								Pencil style air velocity transmitter
Accuracy		S H							Standard ±5% of reading +40 FPM High accuracy ±3% of reading +40 FPM
Velocity Range			01 02 03 04 05 10 15 20						1000 FPM 2000 FPM 3000 FPM 4000 FPM 5 m/s 10 m/s 15 m/s 20 m/s
Electrical Connection				C1 C2 M1					Cable whip 20" (0.5 m) Cable whip 78" (2 m) M12 24" (0.6 m)
Output Type					A B				Analog 0-5 V and 0-10 V BACnet MS/TP
Probe Length						06 12			6" 12"
BACnet Address							127		000-127 whole integer with BACnet output
Options								FC NIST	Factory calibration certificate NIST traceable certificate

MODEL CHART	
Example	AVPT
SCD-PS	100-240 VAC/VDC to 24 VDC power supply
A-AVUL-MTG	Replacement mounting flange
A-AVUL-QFG	Quick fix cable gland for outside the duct installation

AIR VELOCITY TRANSMITTERS

High Accuracy, Field Selectable Ranges

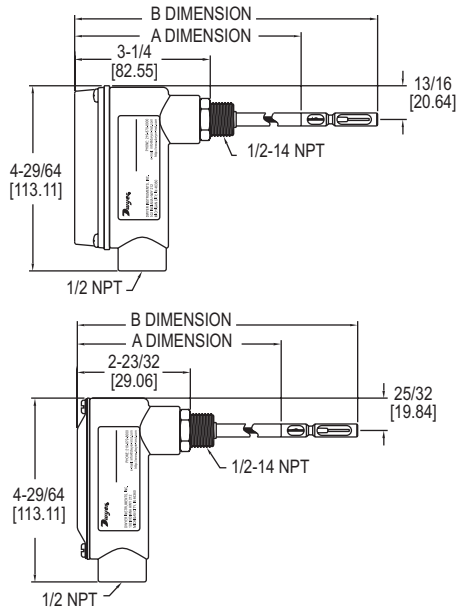

641 AVT WITH DISPLAY OPTION	
A Dimension	B Dimension
7-63/64 [202.80]	9-13/16 [249.24]
13-63/64 [355.20]	15-13/16 [401.64]
19-63/64 [507.60]	21-13/16 [554.04]
26-63/64 [685.40]	28-13/16 [731.84]
32-63/64 [837.80]	34-13/16 [884.24]
37-63/64 [964.80]	39-13/16 [1011.24]

641 AVT WITHOUT DISPLAY OPTION	
A Dimension	B Dimension
7-7/16 [188.91]	9-9/32 [235.74]
13-7/16 [341.31]	15-9/32 [388.14]
19-7/16 [493.71]	21-9/32 [540.54]
26-7/16 [671.51]	28-9/32 [718.34]
29-7/16 [747.71]	34-9/32 [870.74]
37-7/16 [950.91]	39-9/32 [997.74]

The Series 641 Air Velocity Transmitters are the ideal instrument for monitoring air flow. This transmitter uses a heated mass flow sensor which allows for precise velocity measurements at various flow rates and temperatures. The 641's 16 field-selectable ranges provides it the versatility to be selected for several air flow applications. The optional LED produces a complete, low-cost solution for local indication of air flow.

FEATURES/BENEFITS

- Ranges from 250 FPM (1.25 MPS) to 15,000 FPM (75 MPS)
- Optional bright LED display
- Easy push-button set-up
- Compact housing
- 4-20 mA output
- Digital filter for signal damping

APPLICATIONS

- Exhaust stack flow monitoring
- Air control in drying processes
- HVAC air velocity measurements
- Fan supply and exhaust tracking
- Clean room ventilation monitoring

MODEL CHART	
Model	Probe Length*
641-6	6" (152.4 mm)
641-6-LED	6" (152.4 mm)
641-12	12" (304.8 mm)
641-12-LED	12" (304.8 mm)
641-18	18" (457.2 mm)
641-18-LED	18" (457.2 mm)
641-24	24" (609.6 mm)
641-24-LED	24" (609.6 mm)

*Other probe lengths available contact factory.

OPTIONS	
To order add suffix:	Description
-NIST	NIST traceable calibration certificate

Example: 641-6-NIST

ACCESSORIES	
Model	Description
A-156	Universal mounting plate, 1/2" female NPT
A-158	Split flange mounting kit
A-159	Duct mounting gland
641-LED	Field-upgradeable LED

SPECIFICATIONS

Service: Clean air and compatible, non-combustible gases.
Accuracy: 3% FS process gas: 32 to 122°F (0 to 50°C); 4% FS process gas: -40 to 32°F & 122 to 212°F (-40 to 0°C & 50 to 100°C).
Response Time: Flow: 1.5 s to 95% of final value (output filter set to minimum).
Temperature Limits: Process: -40 to 212°F (-40 to 100°C); Ambient: 32 to 140°F (0 to 60°C).
Pressure Limit: 100 psi (6.89 bar) maximum.
Humidity Limit: Non-condensing.
Power Requirements: 12-35 VDC, 10-16 VAC. 1.5 A rating required on supply due to initial power surge drawn by transmitter.
Output Signal: 4-20 mA, isolated 24 V source, 3 or 4-wire connection.
Output Filter: Selectable 0.5-15 (s).
Loop Resistance: 600 Ω max.
Current Consumption: 300 mA max.
Electrical Connections: Screw terminal.
Process Connections: 1/2" male NPT.
Enclosure Rating: Designed to meet NEMA 4X (IP66) for non LED models only.
Mounting Orientation: Unit not position sensitive. Probe must be aligned with airflow.
Weight: 12.6 oz (357.2 g).
Agency Approval: CE.

OPTIONAL DISPLAY VERSION:
Display: 4-1/2 digit 1/2" red LED.
Resolution: 1 FPM, 0.01 MPS (10 FPM @ 10,000 and 15,000 FPM ranges).
Weight: 13.3 oz (377 g).

AIR FLOW SWITCH

Monitors Flow in Ducts with Contact Output and Local LED Indication

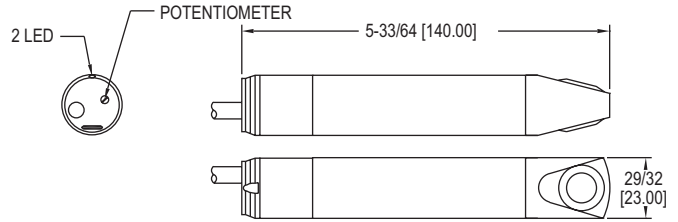

The **Series AVFS Air Flow Switch** is specifically designed to monitor air flow in ducts and provides a 3 A contact output to indicate a change or loss of flow. The AVFS provides a $\pm 5\%$ set point repeatability across a full-scale range of 1-10 m/s (197-1969 fpm) and includes a mounting bracket for quick duct mounting.

FEATURES/BENEFITS

- Integral red/green air flow status LED's
- Flush sensor design limits issues due to dust or particulate in the air flow
- IP65 construction

APPLICATIONS

- Fan monitoring
- Filter monitoring
- Damper feedback
- Air handlers

MODEL CHART	
Model	Description
AVFS-1	80-250 AC/DC power thermo air flow switch
AVFS-2	24 VDC power thermo air flow switch

SPECIFICATIONS	
Air Velocity Range:	197-1969 FPM (1-10 m/s).
Temperature Limits:	5 to 122°F (-10 to 50°C).
Humidity Limits:	0-90% RH.
Wetted Materials:	PBT body, titanium sensor.
Pressure Limit:	14.7 psig (1 bar).
Housing:	PBT.
Repeatability:	$\pm 5\%$ FS.
Switch Type:	N.O. SPST.
Electrical Rating:	3 A @ 30 VDC/250 VAC.
Response Time:	3-60 seconds. Varies with flow and set point.
Power Requirement:	AVFS-1: 80 to 250 AC/DC (47 to 63 Hz AC); AVFS-2: 24 VDC $\pm 25\%$.
Power Consumption:	3 VA.
Electrical Connection:	6.5' (2 m) cable.
Enclosure Rating:	IP65.
Display:	1 Red LED/1 Green LED.
Weight:	7.2 oz (203 g).
Agency Approvals:	CE.

MODEL AAFS

ADJUSTABLE AIR FLOW PADDLE SWITCH

Ranges from 200 to 1800 FPM, Stainless Steel Vane, ABS Housing

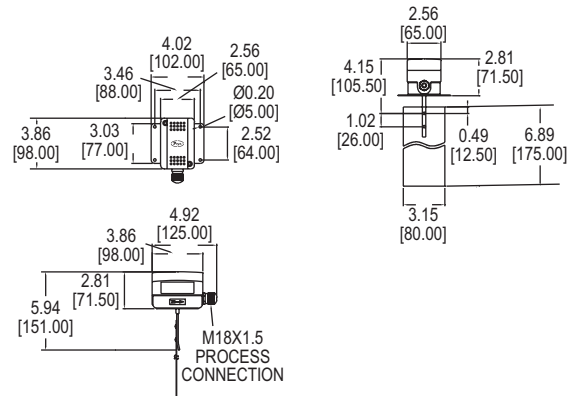

The **Model AAFS Adjustable Air Flow Paddle Switch** is capable of detecting a wide range of air velocities with minimal user calibration. Quality features include a stainless steel vane, galvanized steel base, and ABS enclosure.

FEATURES/BENEFITS

- Adjustable air flow sensitivity from 200 to 1800 FPM
- High current (15 A) rated SPDT contact
- IP65 enclosure rating

APPLICATIONS

- Air flow proving in HVAC systems

MODEL CHART	
Model	Description
AAFS	Adjustable air flow paddle switch

SPECIFICATIONS	
Service:	Air and compatible gas.
Wetted Materials:	Vane: SS; Lever: Brass; Base: Galvanized steel.
Housing:	ABS.
Temperature Limits:	Ambient: -40 to 180°F (-40 to 85°C); Process: -14 to 185°F (-10 to 85°C).
Humidity Limits:	10 to 90%, non-condensing.
Switch Type:	SPDT.
Electrical Rating:	15 (8) A @ 250 VAC.
Electrical Connection:	Screw terminal with M18 x 1.5 cable gland.
Process Connection:	Flange.
Mounting Orientation:	Horizontal duct flow.
Set Point:	Internal screw.
Enclosure Rating:	IP65.
Weight:	13.6 oz (380 g).
Agency Approvals:	CE.

USA: California Proposition 65
 ⚠WARNING: Cancer and Reproductive Harm - www.P65Warnings.ca.gov

Dwyer
MODEL 670

FUME HOOD MONITOR

Ensures Proper Fume Hood Performance

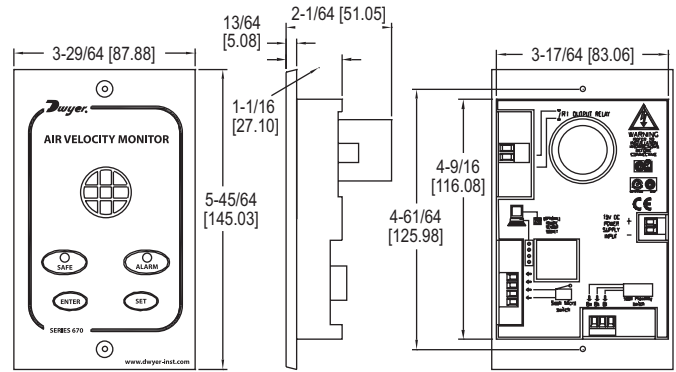

The **Model 670 Fume Hood Monitor** continuously senses air flow through the face of the fume hood, ensuring safe levels of fresh air are exhausting. The 670 provides a highly accurate hot wire sensor to detect very low flows common on fume hoods. The Model 670 comes with everything required to quickly install the unit including a mounting bracket, 24" of tubing for connecting to the inside of the hood wall and a 120 Volt AC power adapter.

FEATURES/BENEFITS

- Flexible surface or flush mounting
- LED safe and alarm status indicators
- Audible alarm
- Sash alarm input
- Night time set-back

APPLICATIONS

- Fume hood ventilation monitoring

MODEL CHART	
Model	Description
670	Fume hood monitor

SPECIFICATIONS

Service: Fume hood face velocity air flow.
Alarm Range: 30-400 FPM (0.15-2.0 m/s).
Alarm Indication: Red LED & audible alarm.
Low Air Velocity Alarm Delay: Fixed 5 secs.
Visual LED Display: Red: Alarm; Green: Normal.
Horn Silence: Yes-temporary and permanent.
Accuracy: Face velocity ±10%.
Temperature Limits: Operating temperature: 55 to 86°F (13 to 30°C); Storage temperature: -40 to 150°F (-40 to 65°C).
Power Requirement: 15 VDC 500 mA; 120 VAC, 60 Hz power transformer included.
Relay Output Low Air Flow Alarm: 5 A @ 250 VAC.
Relay Input For Night Setback: 2 wire rated for 24 VDC usage.
Sash High Indication: Using a two wire micro switch or 3 wire proximity switch input, rated for 24 VDC usage.
Mounting: Semi flush, flush or surface mounted when using included bracket.
Weight: 5.0 oz (141 g).

SERIES AFG

AVERAGING FLOW GRID

Cost Effective Air Flow Station for Ducts up to 60"

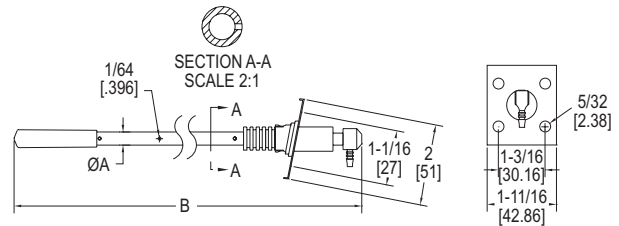
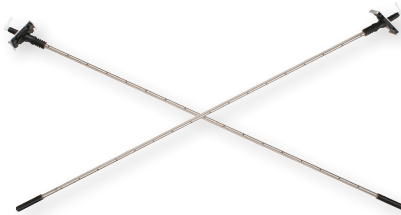

The **Series AFG Averaging Flow Grid** is a fundamental pressure-sensing device designed to sense velocity pressure in an air duct. When this output is connected to a suitable measuring instrument (i.e. manometer, pressure transducer, etc.) it may be used to determine air velocity or air flow rate.

FEATURES/BENEFITS

- Kit complete with 2 probes and installation hardware
- Trimmable length for any duct size up to 60"
- Alternative to costly air flow stations

APPLICATIONS

- To display differential pressure, velocity or volume flow using a micro manometer, gage or transmitter
- To give a warning of over or under flow rate using a pressure switch
- To control air supply in a system by connecting the grid to a pressure transmitter with an electrical output which can be used to feed into a control system
- To display differential pressure on a simple fluid manometer to give visual indication of changes in volume flow rate in the duct

SPECIFICATIONS

Service: Monitor air or compatible gas flow.
Wetted Materials: 304 SS, PVC, polyurethane, acetyl plastics, and neoprene rubber.
Accuracy: ±5%.
Maximum Temperature: 176°F (80°C).
Velocity Range: 295.2 ft/min to 5904 ft/min (1.5 to 30 m/s).
Diameter of Tubes: 5/16" (8 mm) or 5/8" (16 mm).
Maximum Duct Diagonal: 60.4" (153.4 cm).
Maximum Duct Diameter: 59.4" (150.9 cm).
Process Connections: 5/16" barbed.
Weight: AFG-1: 1 lb (454 g); AFG-2: 3 lb (1361 g).

MODEL CHART		
Model	Diameter Tube (Dim. A) in (mm)	Length (Dim. B) in (mm)
AFG-1	5/16 (8)	27 (688)
AFG-2	5/8 (16)	59-4/5 (1518)

METAL AVERAGING FLOW SENSOR

Blade Profile Provides Enhanced Performance and Minimal Flow Disruption

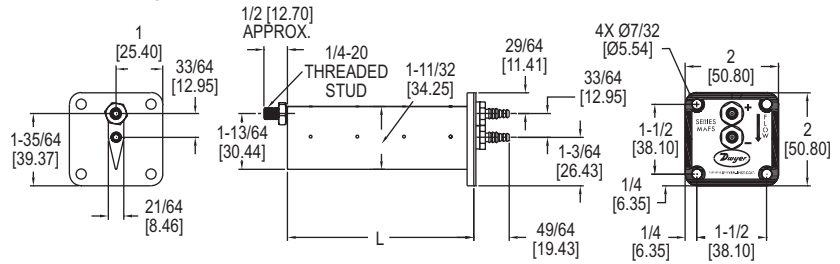

The **Series MAFS Metal Averaging Flow Sensor** is ideal for use with Dwyer Instruments, Inc. precision air velocity gages, transmitters and switches. The Series MAFS uses evenly distributed total and static pressure measuring points to deliver an accurate measurement of velocity pressure in a duct.

FEATURES/BENEFITS

- Blade design limits disruption of air stream
- Lightweight aluminum construction
- Flange mount for rectangular or square ducts

APPLICATIONS

- VAV air flow measurement
- Fume hood exhaust flow verification
- HVAC retrofit air flow measurement

SPECIFICATIONS

Service: Clean air.
Wetted Materials: Aluminum AA6063.
Accuracy: 400 to 9000 FPM (45.7 m/s); ±2% FS, ±3% FS for 6" (160 mm) and 48" (1200 mm) length models.
K-Factor: 0.81, 0.80 for 6" (160 mm) and 48" (1200 mm) lengths, 4" (100 mm) length=0.82.
Maximum Temperature: 400°F (204°C); Gasket: -31 to 230°F (-35 to 110°C).
Minimum Design Flow: 400 FPM (2 m/s).
Maximum Design Flow: 12,000 FPM (60.91 m/s).
Process Connections: Dual barb for 3/16" or 1/4" ID tubing.
Straight Run Requirements: 5 diameters or longest side dimensions.
Agency Approvals: Meets the technical requirements of EU Directive 2011/65/EU (RoHS II).

MODEL CHART

Model	Probe Length (in)	Model	Probe Length (in)	Model	Probe Length (mm)	Model	Probe Length (mm)
MAFS-4	4	MAFS-24	24	MAFS-100MM	100	MAFS-550MM	550
MAFS-6	6	MAFS-26	26	MAFS-125MM	125	MAFS-600MM	600
MAFS-8	8	MAFS-28	28	MAFS-160MM	160	MAFS-630MM	630
MAFS-10	10	MAFS-30	30	MAFS-200MM	200	MAFS-650MM	650
MAFS-12	12	MAFS-32	32	MAFS-250MM	250	MAFS-750MM	750
MAFS-14	14	MAFS-34	34	MAFS-300MM	300	MAFS-800MM	800
MAFS-16	16	MAFS-36	36	MAFS-315MM	315	MAFS-1000MM	1000
MAFS-18	18	MAFS-40	40	MAFS-400MM	400	MAFS-1500MM	1500
MAFS-20	20	MAFS-48	48	MAFS-450MM	450	MAFS-2000MM	2000
MAFS-22	22			MAFS-500MM	500		

SERIES PAFS-1000

AVERAGING FLOW SENSORS

Ideal for Sensing Fan Flow Rates

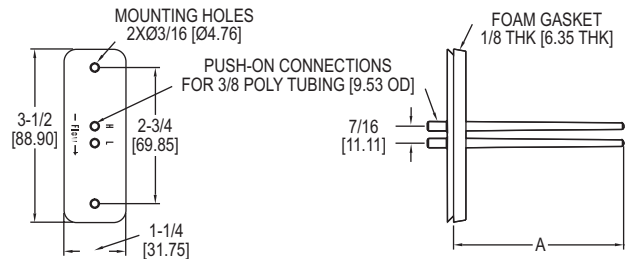
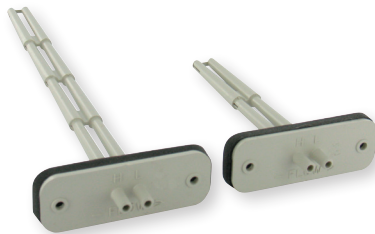

The **Series PAFS-1000 Averaging Flow Sensors** are ideal for sensing velocity pressure in the inlet section of variable air volume terminal units and fan terminal units.

FEATURES/BENEFITS

- Simple mounting flange works with both round or rectangular ducts

APPLICATIONS

- Zone control in HVAC systems
- Retrofit HVAC air flow measurement

MODEL CHART

Model	Length (Dim. A) in (cm)	Model	Length (Dim. A) in (cm)
PAFS-1002	3-5/32 (8.02)	PAFS-1007	14-3/4 (37.47)
PAFS-1003	5-13/32 (13.73)	PAFS-1008	17-1/8 (43.50)
PAFS-1004	7-21/32 (19.55)	PAFS-1009	19-13/32 (49.29)
PAFS-1005	9-29/32 (25.26)	PAFS-1010	21-21/32 (55.01)
PAFS-1006	12-1/2 (31.75)	PAFS-1011	23-29/32 (60.72)

SPECIFICATIONS

Service: Air and compatible gases.
Wetted Materials: ABS/polycarbonate (UL94-5V).
Temperature Limits: Operating: 40 to 120°F (4 to 49°C); Storage: -40 to 140°F (-40 to 60°C).
Process Connection: 1/4" (6 mm) ID, 3/8" (10 mm) OD tubing.
Mounting Orientation: Integral flange with gasket.
Weight: 1 oz (28 g).
Agency Approvals: Meets the technical requirements of EU Directive 2011/65/EU (RoHS II).

DUCT MOUNTED AIRFLOW MEASUREMENT STATIONS

Rectangular, Oval or Circular Configurations

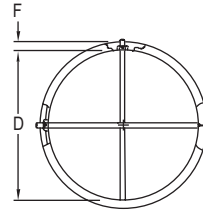
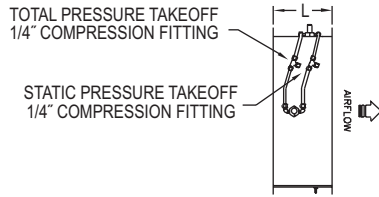
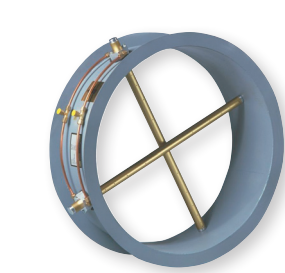

DIMENSIONS - CIRCULAR FLANGE			
Station Size "D"	Flange Thickness	Flange Size "F"	Casing Length "L"
8" - 15"	.064"	1"	6"
16" - 44"	.064"	1-1/2"	6"
45" - 72"	.188"	1-1/2"	10"
73" & over	.188"	2"	12"

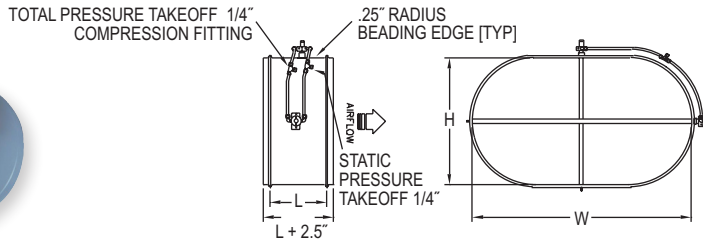
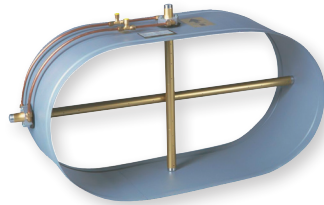

DIMENSIONS - OVAL FLANGE			
Station Width "W"	Flange Thickness	Flange Size "F"	Casing Length "L"
Up to 48"	.064"	1-1/2"	6"
Over 48"	.188"	1-1/2"	8"

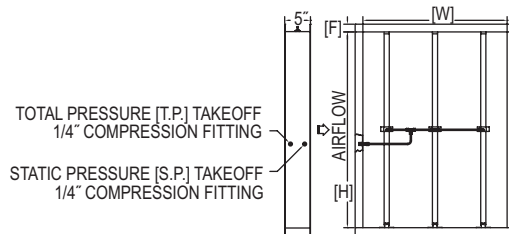

DIMENSIONS - RECTANGULAR FLANGE	
Station Size "H" or "W"	Flange Size "F"
8" - 72"	1-1/2"
73" & Over	2"

The Series FLST Duct Mounted Airflow Measurement Stations utilize an airflow averaging element generating a velocity pressure signal similar to the orifice, venturi, and other primary elements. Single or multiple airflow elements are factory mounted and pre-piped in a casing designed for flanged connection to the ductwork. Multiple elements are joined together for connection to a differential measurement device (gauge, transmitter, etc.) for flow measurement and indication purposes.

FEATURES/BENEFITS

- Low signal-to-noise ratio
- Factory mounted and pre-piped in a flanged duct section (casing)
- Standard construction includes galvanized casing and 6063-T5 anodized aluminum flow sensors
- Standard airflow stations can be operated (in air) continuously in temperatures up to 350°F or intermittently in temperatures up to 400°F

APPLICATIONS

- Building air intake and exhaust flow rate measurement
- HVAC air flow measurement

Circular Models

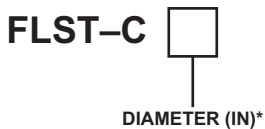

Rectangular or Oval Models

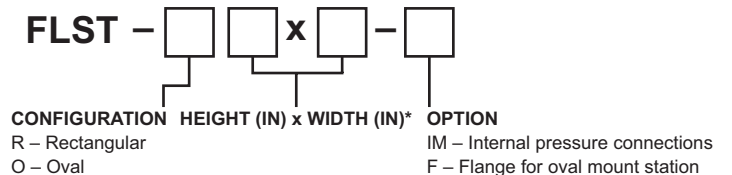

SPECIFICATIONS

Accuracy: Within 2% of actual flow when installed in accordance with published recommendations.
K-Factor: 0.97.
Velocity Range: 100 to 10,000 FPM (0.51-51 m/s).
Wetted Material: Elements: 6063-T5 anodized aluminum; Casings: 16 ga G90 galvanized steel.
Temperature Limits: Galvanized casings and aluminum elements 350°F (177°C) continuous operation (in air) 400°F (204°C) intermittent operation (in air).
Humidity: All airflow stations 0 to 100% non condensing.
Process Connections: 1/4" compression fittings.

Note: When ordering rectangular or oval flow stations, pressure taps will always be located on the longer of the two dimensions.

*Metric dimensions available upon request.

DUCT MOUNTED AIRFLOW MEASUREMENT STATIONS

Integral Flow Straightener, Ideal for Turbulent Measuring Conditions

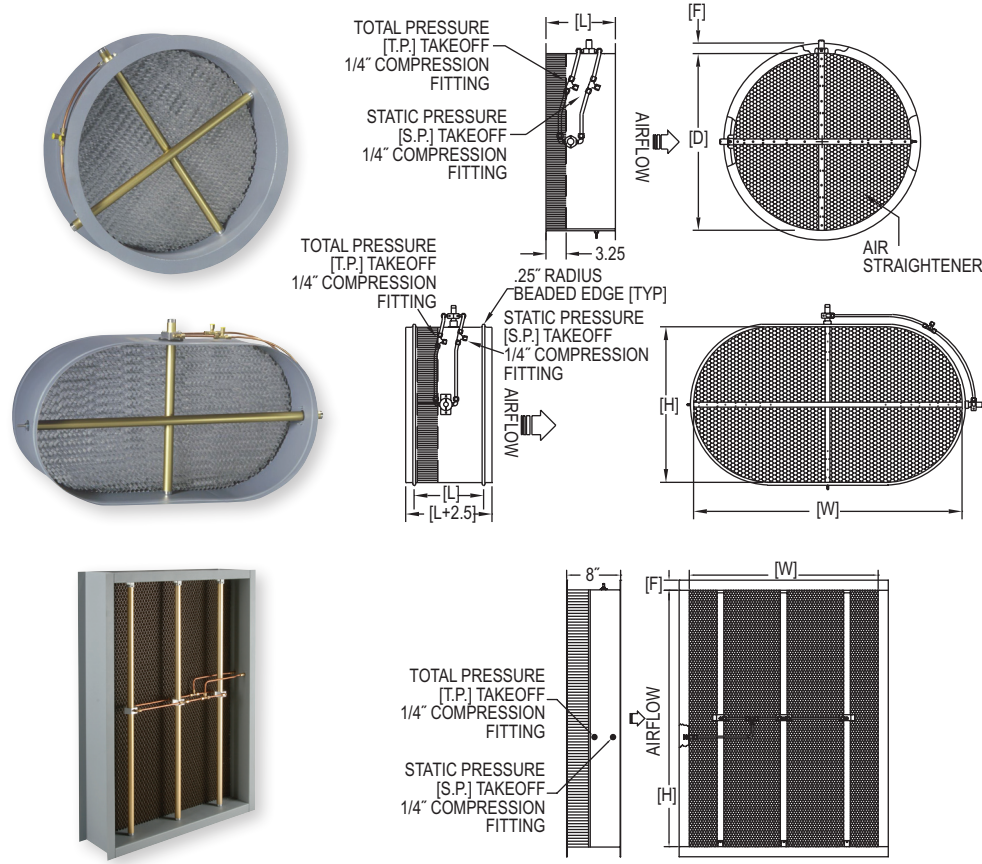

DIMENSIONS - CIRCULAR FLANGE			
Station Size "D"	Flange Thickness	Flange Size "F"	Casing Length "L"
8" - 15"	.064"	1"	8"
16" - 44"	.064"	1-1/2"	8"
45" - 72"	.188"	1-1/2"	10"
73" & over	.188"	2"	12"

DIMENSIONS - OVAL FLANGE (OPTIONAL)			
Station Width "W"	Flange Thickness	Flange Size	*Casing Length "L"
Up to 44"	.064"	1-1/2"	8"
Over 44"	.188"	1-1/2"	10"

*All oval flow stations without flange have a casing length of 8".

DIMENSIONS - RECTANGULAR FLANGE	
Station Size "H" or "W"	Flange Size "F"
8" - 72"	1-1/2"
73" & Over	2"

The **Series STRA Duct Mounted Airflow Measurement Stations** utilize an airflow averaging element generating a velocity pressure signal similar to the orifice, venturi, and other primary elements. Single or multiple airflow elements are factory mounted and pre-piped in a casing designed for flanged connection to the ductwork. Multiple elements are joined together for connection to a differential measurement device (gage, transmitter, etc.) for flow measurement and indication purposes. It has been developed with a honeycomb airflow straightening section for use in duct systems having highly turbulent conditions at the point of measurement.

FEATURES/BENEFITS

- Honeycomb airflow straightening section with 1/2 opening by 3" depth
- Low signal-to-noise ratio
- Factory mounted and pre-piped in a flanged duct section (casing)
- Standard construction includes galvanized casing and 6063-T5 anodized aluminum flow sensors
- Standard airflow stations can be operated (in air) continuously in temperatures up to 350°F or intermittently in temperatures up to 400°F

APPLICATIONS

- Building air intake and exhaust flow rate measurement
- HVAC air flow measurement

Circular Models

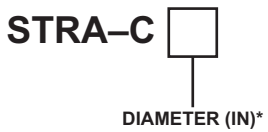

SPECIFICATIONS

Accuracy: Within 2% of actual flow when installed in accordance with published recommendations.
K Factor: 0.97.
Velocity Range: 100 to 10,000 FPM (0.51 to 51 m/s).
Wetted Materials: Elements: 6063-T5 anodized aluminum; Casings: 16 ga G90 galvanized steel, 3003 aluminum air flow straightener.
Temperature Limits: Galvanized casings and aluminum elements 350°F (177°C) continuous operation (in air), 400°F (204°C) intermittent operation (in air).
Humidity Limits: All airflow stations 0 to 100% non condensing.
Process Connections: 1/4" compression fittings.

Rectangular or Oval Models

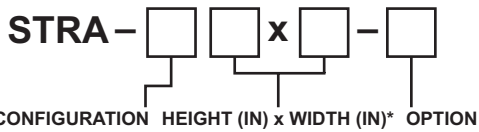

R – Rectangular IM – Internal pressure connections
 O – Oval F – Flange for oval mount station

Note: When ordering rectangular or oval flow stations, pressure taps will always be located on the longer of the two dimensions.

*Metric dimensions available upon request.

INSERTION THERMAL ENERGY METER

Field Adjustable, BACnet/Modbus® Outputs



IEFB-X-X-TXX

IEFB-X-X-TXX
Shown with
A-IEF-VLV-BR
accessory valve

A-IEFB-THW-XX (2)

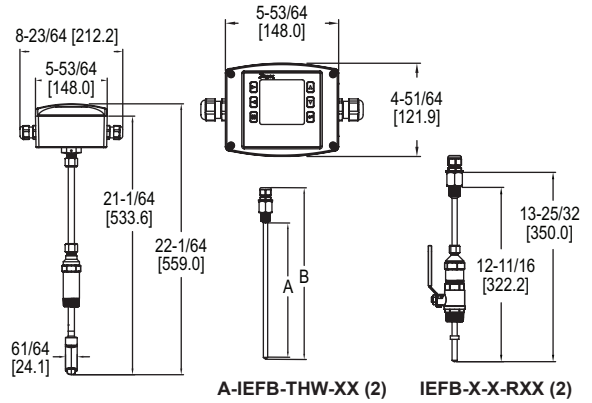
Hot-tap thermowells for model
IEFB-X-X-RXX (2) shown
with A-IEFB-VLV-BR-1
accessory valve

A-IEFB-THW-XX (2)

IEFB-X-X-RXX (2)

THERMOWELL MODEL CHART

Model	A	B
A-IEFB-THW-4	4-11/16" (119.0 mm)	5-25/32 (146.8 mm)
A-IEFB-THW-6	6-11/16" (169.8 mm)	7-25/32 (197.6 mm)

The Series IEFB is a field-adjustable insertion thermal energy meter that uses electromagnetic technology to accurately and reliably measure fluid velocity and energy consumption. The high accuracy IEFB is adjustable to fit pipe sizes from 4 to 10" (100 to 250 mm), while the standard accuracy IEFB fits pipe sizes 4 to 36" (100 to 900 mm). The energy meter is simple to install and incorporates a temperature meter and calculator into a single unit. The IEFB incorporates a temperature meter and a calculator into a single unit. The LCD display provides clear readings of the meter's values, including temperature and energy consumption, making it ideal for installation on chillers, boilers, and other heating and cooling applications. The high measuring accuracy and long lifetime keeps annual operating costs at a minimum. In addition, it offers several output options, including selectable BACnet MS/TP or Modbus® RTU communications protocol over 2-wire RS-485 and standard analog, frequency, and alarm outputs.

FEATURES/BENEFITS

- Flexible, field configurable setup displays (-LCD integral option or remote accessory A-IEF-DSP) accommodate a variety of application configurations. Application information is display selectable and includes pipe size, pipe material, liquid type, analog output, pulse/frequency output, alarm outputs, communication, outputs, damping, and calibration factor
- High performance accuracy is maintained through changes in temperature, density and/or viscosity
- The Setup Wizard and installation tool are simple to use, providing quick and precise installation
- Accessory setup kit A-IEF-KIT comes with a thickness gage and measuring tape to ensure exact installation depth
- The meter has no moving parts and electrodes that discourage fouling, which gives the meter a long lifecycle and minimizes the need for maintenance
- Hot-tap isolation valve accessories allow for easy installation and removal in operational systems without system downtime

APPLICATIONS

- Monitoring chiller cooling output performance
- Industrial boiler heating performance
- Energy efficiency monitoring
- Optimization of heat energy performance
- Commercial and residential heat energy consumption and metering
- District heating and cooling monitoring
- Energy cost allocation monitoring

SPECIFICATIONS

Service: Compatible clean or dirty non coating, conductive liquids.

Range: 0 to 20 ft/s (0 to 6 m/s).*

Wetted Materials: Body shaft/fitting: 316 SS; Electrodes: 316 SS; Electrode cap: Polymer/polystyrene; O-ring: Silicone; Thermowells: 304 SS.

BTU Accuracy per EN1434/ASTM E3137/CSA C900.1-13: High Accuracy Units: Class 2 for 2 to 20 ft/s (0.6 to 6 m/s)**; Standard Accuracy Units: Class 3 for 6.5 to 20 ft/s (2 to 6 m/s)**.

Flow Sensor Accuracy: High Accuracy Units: $\pm 0.5\%$ of reading at calibrated velocity, $\pm 1\%$ of reading from 2 to 20 ft/s (0.6 to 6 m/s) ± 0.02 ft/s (± 0.006 m/s) at < 2 ft/s (0.6 m/s); Standard Accuracy Units: $\pm 1\%$ FS.

Temperature Accuracy: Class B $\pm (0.30 + 0.005 \cdot t)^\circ\text{C}$ per EN60751.

Differential Temperature Accuracy: $E_t = \pm (0.5 + 3^\circ\Delta\theta_{\text{min}}/\Delta\theta) \%$ per EN1434.

Calculator Accuracy: $E_c = \pm (0.5 + \Delta\theta_{\text{min}}/\Delta\theta) \%$ per EN1434.

Temperature Compensation: 140 to 220°F (60 to 104.4°C) $< 2\%$ error over $\pm 30^\circ\text{F}$ (-1.1°C) change, 40 to 70°F (4.4 to 21.1°C) $< 2\%$ error over $\pm 10^\circ\text{F}$ (-12.2°C) change.

Temperature Limits: Ambient: -20 to 160°F (-29 to 71°C)**; LCD: -4 to 158°F (-20 to 70°C); Process: 15 to 250°F (-9 to 121°C); Storage: -40 to 185°F (-40 to 85°C).

Process Connection: Flowmeter: 1" NPT or BSPT with accessory full port ball valve options; Thermowell: (2) 1/2" NPT or BSPT thermowell with 1" full port ball valve options.

Pressure Limit: 400 psi (27.6 bar) @ 100°F (37.8°C).

Pressure Drop: < 0.1 psi at 12 ft/s in 4" (< 0.01 bar at 3.7 m/s in 100 mm) and larger pipe.

Outputs: (1) Analog: 4-20 mA, 0-5 V, 0-10 V or 2-10 V (display selectable); (1) Pulse/Frequency: 0-15 V peak pulse, 0 to 500 Hz or scalable pulse output (display selectable); (2) Alarm: Empty pipe detection or minimum/maximum velocity, (display selectable) and reverse flow output indication.

Power Requirements: 12-42 VDC, .25 A @ 24 VDC; 12-36 VAC.

Electrical Connection: Removable terminal blocks, (2) model selectable 1/2" female NPT conduit connection, (2) PG 16 gland or (2) PG 16 gland with 10 ft (3 m) 9 conductor 22 AWG plenum rated cables, accessory cable lengths up to 200 ft (61 m) optional.

Display (-LCD option): 2 x 2" (50 x 50 mm) graphic LCD with backlight.

Conductivity: > 20 microsiemens.

Enclosure Material: Powder coated die cast aluminum.

Enclosure Ratings: NEMA 6P (IP68) (Non display models); NEMA 4X (IP66) (-LCD option).

Agency Approvals: BTL.

COMMUNICATIONS (-COM OPTION)

Type: BACnet MS/TP or Modbus® RTU communication protocol (default disabled, display selectable).

Supported Baud Rates: 9600, 19200, 38400, 57600, 76800, or 115200 bps (display selectable).

Device Load: 1/8 unit load.

ADDITIONAL SPECIFICATIONS

Applicable Pipe Material: Most popular plastic and metal pipes; i.e. Carbon steel, SS, copper, UPVC/PVDF, galvanized steel, mild steel, and brass.

Applicable Pipe Size: 4 to 36" (100 to 900 mm), model dependent. See model chart.

Diameter Length Requirements: > 10 upstream, > 5 downstream.

Temperature Resistance: Matched 4 wire platinum RTD's.

Relative Humidity: 10 to 90% non-condensing.

Output Impedance: 4-20 mA: 536 Ω ; 5V: 500 Ω ; 10V: 1.27k Ω .

*For max flowrates > 10 ft/s (3 m/s) order option -CC.

**Verified at standard temperature 73.4°F (23°C) refer to listed standards for detailed accuracy formulations.

INSERTION THERMAL ENERGY METER

Field Adjustable, BACnet/Modbus® Outputs

MODEL CHART						
Example	IEFB	-L	N	-CND	-R10	-LCD
Series	IEFB					Insertion thermal energy meter
Accuracy		L G S F I E T H				Standard accuracy <10" (250 mm) pipe; 1% FS Standard accuracy >10" (250 mm) pipe; 1% FS Standard accuracy 4 to 36" (100 to 900 mm) pipe; 1% FS High accuracy 4" (100 mm) pipe; 1% of reading High accuracy 6" (150 mm) pipe; 1% of reading High accuracy 8" (200 mm) pipe; 1% of reading High accuracy 10" (250 mm) pipe; 1% of reading High accuracy 4 to 10" (100 to 250 mm) pipe; 1% of reading
Process Connection			N B			1" Male NPT 1" Male BSPT
Housing Electrical Connection				CND PG 10		1/2" female NPT PG 16 gland without cable PG 16 gland with (2) 10' (3 m) cables
Temperature Sensors					T10 T20 T50 R10 R20 R50	(2) 10' (3 m) PT temperature sensors* (2) 20' (6 m) PT temperature sensors* (2) 50' (15 m) PT temperature sensors* (2) 10' (3 m) PT temperature sensors with hot-tap thermowells (2) 20' (6 m) PT temperature sensors with hot-tap thermowells (2) 50' (15 m) PT temperature sensors with hot-tap thermowells
Options						LCD Integral LCD display COM BACnet or Modbus® communications protocol (display selectable) NIST NIST traceable calibration certification for flow and temperature FC Factory calibration certification for 0.5% of reading at single point CC Custom configuration (required input)

*Thermowells not included. Refer to accessories model chart to purchase permanent thermowells.

ACCESSORIES	
Model	Description
A-IEF-KIT	Setup kit (includes setup display, thickness gage, and measuring tape) and universal power adapter
A-IEF-DSP	Setup display
A-IEF-VLV-BR†	1-1/4" full port isolation valve brass**
A-IEF-VLV-SS†	1-1/4" full port isolation valve 316 SS
Thermowells	
A-IEFB-THW-4	(2) 1/2" NPT, 4" thermowell for 4 to 7" pipe
A-IEFB-THW-6	(2) 1/2" NPT, 6" thermowell for ≥ 8" pipe
A-IEFB-THW-4-BSPT	(2) 1/2" BSPT, 4" thermowell for 4 to 7" pipe
A-IEFB-THW-6-BSPT	(2) 1/2" BSPT, 6" thermowell for ≥ 8" pipe
Hot-Tap Valves	
A-IEFB-VLV-BR-1†	(2) 1" NPT full port isolation valve brass for temperature sensor with 1" branch outlet and 1" nipple**
A-IEFB-VLV-SS-1†	(2) 1" NPT full port isolation valve 316 SS for temperature sensor with 1" branch outlet and 1" nipple

**Brass fittings and pipe are not to be used with NSF Certified models. Brass valves are non-RoHS compliant.
†BSPT valves also available

Modbus® is a registered trademark of Schneider Automation, Inc.

SERIES A-IEF

REMOTE DISPLAY FOR SERIES IEF AND IEFB

Convenient Access to IEF & IEFB Meter Readings

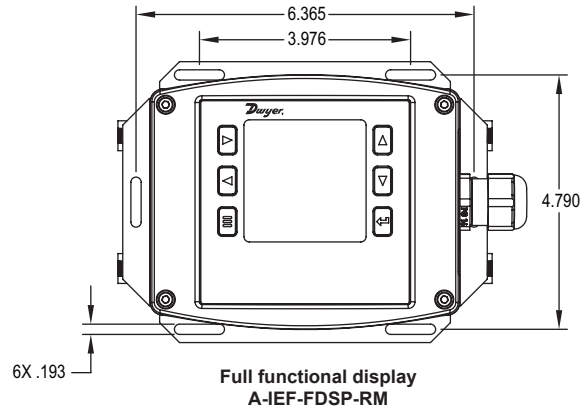
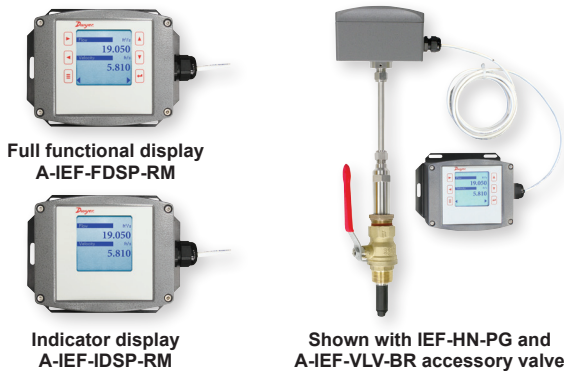

The Series A-IEF Remote Display can be installed almost anywhere near a Series IEF flow transmitter or IEFB thermal energy meter. Both the indicator display (A-IEF-IDSP-RM) and the full functional display (A-IEF-FDSP-RM) have a maximum display cable length of 100 ft (30 m) to permit easy viewing of flow readings. The full functional display allows for convenient adjustment of configuration settings and allows the user to save the IEF or IEFB configuration settings to a computer for printing.

FEATURES/BENEFITS

- Full functional display can be used to set up the IEF/IEFB and adjust the settings if it is installed in a hard-to-reach location.
- Indicator display makes it convenient to read process values if the meter is inaccessible.
- Varying cable lengths of up to 100 ft (30 m) allows for flexible installation on a wall or pipe mount.
- Easy to install and wire in the field.

APPLICATIONS

- Mechanical rooms with a small footprint
- Hard-to-reach piping
- Boilers and chillers
- Chilled water
- Condenser water
- Make-up water
- Heating water
- Boiler feed water
- Steam condensate

SPECIFICATIONS

Temperature Limits: Ambient: -4 to 158°F (-20 to 70°C); Storage: -40 to 185°F (-40 to 85°C).
Display: 3.3" diagonal graphic LCD. Backlight (full functional display only).
Enclosure Material Housing: Powder coated die cast aluminum.
Enclosure Rating: NEMA 4X (IP66).
Electrical Connection: Removable terminal blocks, #22 AWG (100 ft (30 m) max).
Mounting: Wall or pipe mount.
Mounting Orientation: Any orientation.
Weight: 2.46 lbs (1.12kg).
Agency Approvals: CE.

MODEL CHART

Model	Description
A-IEF-IDSP-RM	A-IEF-DSP-RM indicator remote display
A-IEF-FDSP-RM	A-IEF-DSP-RM full functional remote display

ACCESSORIES

Model	Description
A-IEF-CBL-50	Plenum rated cable 50 ft (15.2 m)

Modbus® is a registered trademark of Schneider Automation, Inc.

INSERTION ELECTROMAGNETIC FLOW TRANSMITTER

Field Configurable, High Accuracy, BACnet or Modbus® Protocol



Shown with A-IEF-VLV-BR** accessory valve



-LCD option shown

A-IEF-KIT

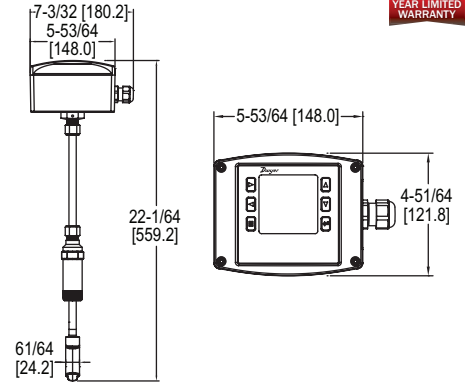

The Series IEF Insertion Electromagnetic Flow Transmitter is an adjustable insertion flowmeter featuring electromagnetic technology that accurately and reliably measures fluid velocity in addition to providing several continuous signal outputs. This series is specifically designed to offer superior performance paired with simple installation and use. One unit is adjustable to fit pipe sizes from 4 to 36" (102 to 914 mm), and offers several output options including selectable BACnet MS/TP or Modbus® RTU communications protocol over 2-wire RS-485 in addition to the standard analog, frequency and alarm outputs.

FEATURES/BENEFITS

- Field configurable setup displays (-LCD integral option or remote accessory A-IEF-DSP) allow for ultimate flexibility by accommodating a variety of application configurations with one model through multiple display configurations i.e. pipe size, pipe material, liquid type, analog output, pulse/frequency output, alarm outputs, communication outputs, damping, and calibration factor.
- High performance accuracy is maintained through changes in temperature, density or viscosity.
- Setup Wizard and installation tool are simple to use allowing for quick and precise installation.
- Accessory setup kit A-IEF-KIT ensures exact installation application depth with included thickness gage and measuring tape.
- Long Life Cycle and minimal maintenance requirements with no moving parts to wear or break and electrodes that discourage fouling.
- Isolation valve accessory options allow for installation in operational systems via hot-tap kit or easy removal without system downtime.
- NIST traceable pass/fail verification certificate included standard for Carbon Steel Schedule 40 pipes sized 4" (102 mm), 6" (150 mm), 8" (200 mm), and 10" (250 mm) with high accuracy option; 10" (250 mm) with standard option.

APPLICATIONS

- Boiler feed water
- Chilled water
- Open and closed loop condenser water
- Irrigation system
- Municipal water distribution
- Process and coolant flow
- Ground water remediation
- Chemical processing
- Pump protection
- Wastewater
- Mining

SPECIFICATIONS

Service: Compatible clean or dirty non coating, conductive liquids.
Range: 0 to 20 ft/s (0 to 6 m/s).*
Wetted Materials: Body shaft/fitting: 316 SS; Electrodes: 316 SS; Electrode cap: Polymer/Polystyrene; O-ring: Silicon.
Accuracy: High accuracy units: ±0.5% of reading at calibrated velocity; ±1% of reading from 2 to 20 ft/s (0.6 to 6 m/s); ±0.02 ft/s (±0.006 m/s) at < 2 ft/s (0.6 m/s); Standard accuracy units: ±1% FS.
Temperature Limits: Ambient: -20 to 160°F (-29 to 71°C); Process: 15 to 250°F (-9 to 121°C); Storage: -40 to 185°F (-40 to 85°C).
Process Connection: 1" NPT or BSPT with accessory full port ball valve options.
Pressure Limits: 400 psi (27.6 bar) @ 100° F (37.8°C).
Pressure Drop: < 0.1 psi at 12 ft/s in 4" (101.6 mm) and larger pipe.
Outputs: (1) Analog: 4-20 mA, 0-5 V, 0-10 V or 2-10 V (display selectable); (1) Pulse/Frequency: 0 to 15 V peak pulse, 0 to 500 Hz or scalable pulse output (display selectable); (2) Alarm: (1) Empty pipe detection or minimum/maximum velocity, (display selectable); (1) Reverse flow output indication.
Power Requirements: 12-42.4 VDC, .25 A @ 24 VDC; 12-36 VAC.

Electrical Connection: Removable terminal blocks, model selectable 1/2" female NPT conduit connection, PG 16 gland or PG 16 gland with (2) 10 ft (3 m) 9 conductor 22 AWG plenum rated cables, accessory cable lengths up to 200 ft (61 m) optional.
Display (-LCD option): 2" (5.08 cm) x 2" (5.08 cm) graphic LCD with backlight.
Conductivity: >20 microsiemens.
Enclosure Material: Powder coated die cast aluminum.
Enclosure Ratings: NEMA 6P (IP68) (Non display models); NEMA 4X (IP66) (-LCD option).
Agency Approvals: BTL, CE, NSF/ANSI 61 and 372.

COMMUNICATIONS (-COM OPTION)
Type: BACnet MS/TP or Modbus® RTU communication protocol (default disabled, display selectable).
Supported Baud Rates: 9600, 19200, 38400, 57600, 76800, or 115200 bps (display selectable).
Device Load: 1/8 unit load.

ADDITIONAL SPECIFICATIONS
Applicable Pipe Material: Most popular plastic and metal pipes; i.e. Carbon steel, SS, copper, UPVC/PVDF, galvanized steel, mild steel, and brass.[†]
Applicable Pipe Size: 4-36" (101 to 914 mm), model dependent. See model chart.
Diameter Length Requirements: >10 upstream; >5 downstream.
Glycol: 0 to 100% display selectable.

*For max flowrates >10 ft/s (3 m/s) order option -CC.
[†]Brass fittings and pipe are not to be used with NSF Certified models.

MODEL CHART						
Example	IEF	-H	N	-CND	-LCD	IEF-HN-CND-LCD
Series	IEF					Insertion electromagnetic flow transmitter
Accuracy		L G S F I E T H				Standard accuracy <10" (250 mm) pipe; 1% FS Standard accuracy >10" (250 mm) pipe; 1% FS Standard accuracy 4 to 36" (100 to 900 mm) pipe; 1% FS High accuracy 4" (100 mm) pipe; 1% of reading High accuracy 6" (150 mm) pipe; 1% of reading High accuracy 8" (200 mm) pipe; 1% of reading High accuracy 10" (250 mm) pipe; 1% of reading High accuracy 4 to 10" (100 to 250 mm) pipe; 1% of reading
Process Connection			N B			1" male NPT 1" male BSPT
Housing Electrical Connection				CND PG 10		1/2" female NPT conduit connection without cable PG gland without cable PG gland with 10' (3 m) cable
Options					LCD COM NIST FC CC NW	Integral LCD display BACnet or Modbus® communication protocol (display selectable) Six point NIST traceable calibration certificate Factory calibration certificate for 0.5% of reading at single point Custom configured for specific installation NSF certified
Note: For CC option, must provide completed configuration paperwork.						

ACCESSORIES	
Model	Description
A-IEF-KIT	Setup kit (includes setup display, thickness gage and measuring tape), and universal power adapter
A-IEF-DSP	Setup display
A-IEF-CBL-50	Plenum rated cable 50 ft (15.2 m)
A-IEF-VLV-BR	1-1/4" full port isolation valve brass**
A-IEF-VLV-SS	1-1/4" full port isolation valve 316 SS
A-IEF-PA	AC wall adapter
**Brass fittings and pipe are not to be used with NSF Certified models. Brass valves are non-RoHS compliant.	

Modbus® is a registered trademark of Schneider Automation, Inc.

A-IEF Remote Display now available: See page 62

ULTRASONIC ENERGY METERS

Flow & Temperature Monitoring Capability, Modbus® or BACnet Communication



TUF-150/400

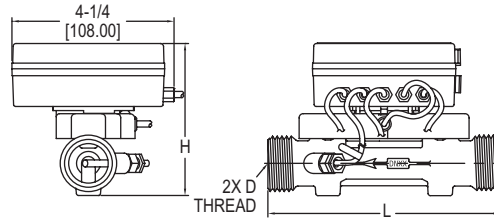

DIMENSIONS in [mm]				
Model	L	D	H	
TUF-150-XX	4-21/64 [110.00]	G3/4B	3-31/32 [101.00]	
TUF-200-XX	5-1/8 [130.00]	G1B	3-31/32 [101.00]	
TUF-250-XX	6-19/64 [160.00]	G11/4B	4-11/64 [106.00]	
TUF-320-XX	7-3/32 [180.00]	G11/2B	4-29/64 [113.00]	
TUF-400-XX	7-7/8 [200.00]	G2B	4-49/64 [121.00]	



TUF-500

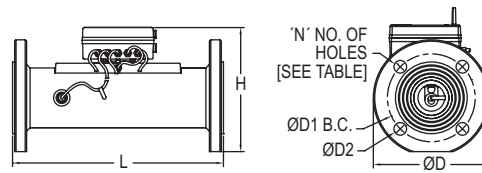

DIMENSIONS in [mm]						
Model	L	ØD	H	ØD1	ØD2	N
TUF-500-XX	7-7/8 [200]	6-1/2 [165.00]	9-27/32 [250]	4-59/64 [125.00]	45/64 [18.00]	4
TUF-650-XX	7-7/8 [200]	7-9/32 [185.00]	10-7/16 [265]	5-45/64 [145.00]	45/64 [18.00]	4
TUF-800-XX	8-55/64 [225]	7-7/8 [200.00]	11-1/32 [280]	6-19/64 [160.00]	45/64 [18.00]	8
TUF-1000-XX	9-27/32 [250]	8-21/32 [220.00]	12-13/64 [310]	7-3/32 [180.00]	45/64 [18.00]	8
TUF-1250-XX	9-27/32 [250]	9-27/32 [250.00]	12-63/64 [330]	8-17/64 [210.00]	45/64 [18.00]	8



The Series TUF Ultrasonic Energy Meters are highly accurate and stable energy meter that utilizes ultrasonic technology to measure heating and cooling energy consumption. The Series TUF is a compact meter with a flowmeter and energy calculator in one, making it great for installation on chillers and boilers.

FEATURES/BENEFITS

- Lower maintenance costs with local parameter display and no moving parts
- Serial communication output allows for easy transfer of data
- Flow and temperature monitor in one unit eliminates the need for multiple units

APPLICATIONS

- Heat metering
- Utilities billing
- Tenant billing
- Monitoring of water heating or cooling: radiators, fan coils

INSTRUCTIONS FOR ORDERING

- Choose 1 ultrasonic energy meter model (includes 2 BSPP pipe fittings, 2 tightening nuts, 2 O-rings, and 1 thermowell with welding collar)
- Choose 1 pipe fitting model given the appropriate fitting size if NPT or BSPT connections are required (for DN15 to DN40 only)*

Example: TUF-150-MD, Fitting Size: A, select pipe fitting Model WM-ACC-C01 or WM-ACC-C11.

SPECIFICATIONS

Service: Clean, compatible liquids.
Wetted Materials: Brass and 316L SS.
Range: See chart.
Display: 8-digit LED.
Accuracy: BTU: EN1434/CJ128 Class 2; Flow: $\pm(2+(0.02 Q_p / Q))\%$; Temperature: $\pm 0.1^\circ\text{C}$.
Power Requirements: 24 VDC/VAC (model dependent) or 3.6 V ER26500 lithium metal battery, user supplied and installed, battery acts as back-up if power is lost.
Power Consumption: 1 W.
Temperature Limits: Ambient: 41 to 131°F (5 to 55°C); Process: 36 to 203°F (2 to 95°C).
Humidity Limit: < 93%.

Pressure Limits: 232 psi (16 bar) for DN15 to DN40; 362 psi (25 bar) for >DN50.
Pressure Drop: < 1.5 psi (10 kPa).
Process Connection: See chart.
Serial Communications: Modbus® RTU or BACnet MSTP (selectable)**.
Enclosure Rating: IP65.
Enclosure Material: Plastic.
Repeatability: Flowmeter: 1%.
Electrical Connections: 3' (0.91 m) 4x0.2 mm² cable with terminal block.
Flow Direction: Unidirectional.
Mounting Orientation: Horizontal or vertical.
Weight: See chart.
Agency Approvals: CE.

**M-BUS available upon request.

MODEL CHART										
Ultrasonic Energy Meter Model	Body Size†	Pipe Size		Fitting Size	Communication	Meter Connection	GPM (LPM)			Weight lb (kg)
		in	mm				Min Flow (Qi)	Nominal Flow Range (Qp)	Max Flow (Qs)	
TUF-150-MD	DN15	1/2	15	A	Modbus®	G-3/4	0.1 (0.5)	6.6 (25)	13 (50)	3.1 (1.4)
TUF-200-MD	DN20	3/4	20	B	Modbus®	G1	0.2 (0.8)	11 (42)	22 (83)	3.1 (1.4)
TUF-250-MD	DN25	1	25	C	Modbus®	G1-1/4	0.3 (1.2)	15 (58)	31 (117)	4.1 (1.8)
TUF-320-MD	DN32	1-1/4	32	D	Modbus®	G1-1/2	0.5 (2)	26 (100)	53 (200)	5.2 (2.3)
TUF-400-MD	DN40	1-1/2	40	E	Modbus®	G2	0.9 (3)	44 (167)	88 (333)	6.6 (3)
TUF-500-MD*	DN50	2	50	-	Modbus®	Flange	1.3 (5)	66 (250)	132 (500)	33 (15)
TUF-650-MD	DN65	2-1/2	65	-	Modbus®	Flange	2.2 (8.3)	110 (417)	220 (833)	10.1 (4.6)
TUF-800-MD	DN80	3	80	-	Modbus®	Flange	3.5 (13.3)	176 (667)	352 (1333)	13.5 (6.1)
TUF-1000-MD	DN100	4	100	-	Modbus®	Flange	5.3 (20)	264 (1000)	528 (2000)	16.5 (7.5)
TUF-1250-MD	DN125	5	125	-	Modbus®	Flange	8.8 (33)	440 (1667)	881 (3333)	21.1 (9.6)
TUF-150-BN	DN15	1/2	15	A	BACnet	G-3/4	0.1 (0.5)	6.6 (25)	13 (50)	3.1 (1.4)
TUF-200-BN	DN20	3/4	20	B	BACnet	G2	0.2 (0.8)	11 (42)	22 (83)	3.1 (1.4)
TUF-250-BN	DN25	1	25	C	BACnet	G1-1/4	0.3 (1.2)	15 (58)	31 (117)	4.1 (1.8)
TUF-320-BN	DN32	1-1/4	32	D	BACnet	G1-1/2	0.5 (2)	26 (100)	53 (200)	5.2 (2.3)
TUF-400-BN	DN40	1-1/2	40	E	BACnet	G2	0.9 (3)	44 (167)	88 (333)	6.6 (3)
TUF-500-BN*	DN50	2	50	-	BACnet	Flange	1.3 (5)	66 (250)	132 (500)	33 (15)
TUF-650-BN	DN65	2-1/2	65	-	BACnet	Flange	2.2 (8.3)	110 (417)	220 (833)	10.1 (4.6)
TUF-800-BN	DN80	3	80	-	BACnet	Flange	3.5 (13.3)	176 (667)	352 (1333)	13.5 (6.1)
TUF-1000-BN	DN100	4	100	-	BACnet	Flange	5.3 (20)	264 (1000)	528 (2000)	16.5 (7.5)
TUF-1250-BN	DN125	5	125	-	BACnet	Flange	8.8 (33)	440 (1667)	881 (3333)	21.1 (9.6)
Model		Power Requirements								
TUF-XXX-XX		24 VAC/VDC								
TUF-XXX-XX-DC		24 VDC								

*A pipe fitting is required to use the DN15 to DN40 energy meters. The DN50 has a flange connection and does not require a pipe fitting.
 †For additional sizes up to 8" (203.2 mm) contact factory.

MODEL CHART							
Fitting Size	Pipe Fitting Model*	Process Connection Size	Weight lb (kg)	Fitting Size	Pipe Fitting Model*	Process Connection Size	Weight lb (kg)
A	WM-ACC-C01	1/2" NPT	0.6 (0.3)	C	WM-ACC-C13	1" BSPT	1.8 (0.8)
A	WM-ACC-C11	1/2" BSPT	0.6 (0.3)	D	WM-ACC-C04	1-1/4" NPT	2.3 (1.1)
B	WM-ACC-C02	3/4" NPT	1.2 (0.5)	D	WM-ACC-C14	1-1/4" BSPT	2.3 (1.1)
B	WM-ACC-C12	3/4" BSPT	1.2 (0.5)	E	WM-ACC-C05	1-1/2" NPT	4.4 (2)
C	WM-ACC-C03	1" NPT	1.8 (0.8)	E	WM-ACC-C15	1-1/2" BSPT	4.4 (2)

*Each model includes 1 fitting.

USA: California Proposition 65
 ⚠WARNING: Cancer and Reproductive Harm
 www.P65Warnings.ca.gov

Modbus® is a registered trademark of Schneider Automation, Inc.

PADDLEWHEEL FLOW SENSOR

Non-Magnetic Sensing, Adjustable for 1-1/2 to 40" (38.1 to 1016 mm) Pipe, Pulse or 4-20 mA

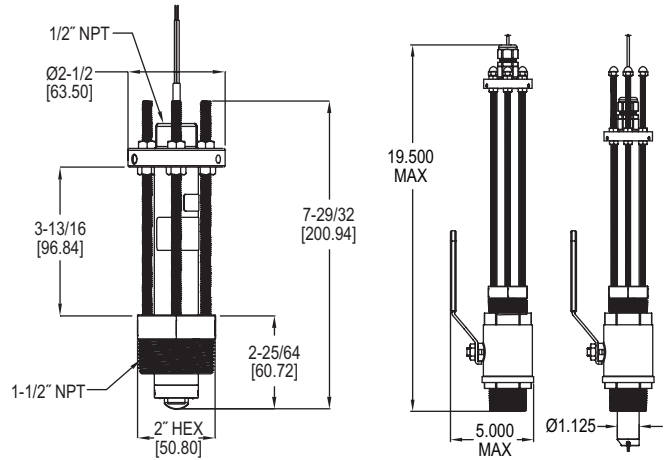
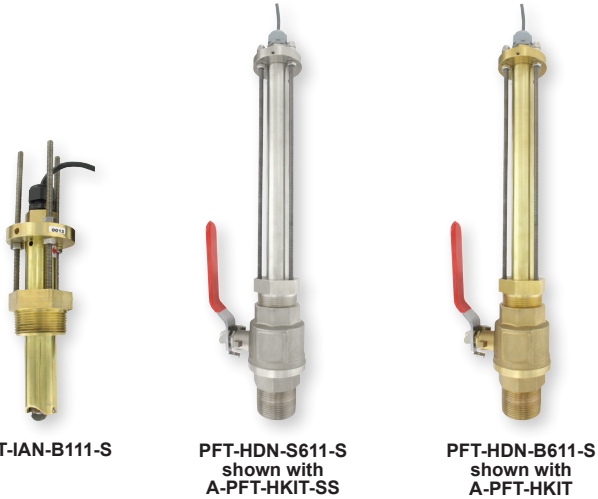

The Series PFT Paddlewheel Flow Sensor is used to monitor liquid flow rates in pipes from 1-1/2 to 40" (40-1016 mm). The unit has one size-adjustable sensor and is available in brass or 316 SS body. The unit outputs a frequency proportional pulsed or 4-20 mA output. The pulse models are a square wave output signal with frequency proportional to the flow velocity and the 4-20 mA models have a linear output of the velocity with 4 mA equal to 0 ft/s and 20 mA equal to 25 ft/s.

FEATURES/BENEFITS

- Bearings and shaft offer excellent wear protection even in applications with particulate for long life
- Weatherproof and submersible rated for irrigation applications
- One unit adjustable over a large pipe size range
- Multiple wetted material choices offer application versatility
- Integral 4-20 mA output with no need for additional external components
- Sensor technology uses inductive sensing to sense the blades of the impeller therefore does not use magnets allowing low flow rate monitoring with no concerns regarding magnetic material in the flow

APPLICATIONS

- Irrigation
- Ground water remediation
- Cooling systems
- Pump protection
- Leak detection
- Filtration systems

SPECIFICATIONS

Service: Water-based fluids.
Range: 1.2 to 25 ft/s (0.37 to 7.62 m/s).
Wetted Materials: Body and fitting: Brass or 316 SS; fitting O-ring: FKM standard, silicone or Buna-N optional; impeller: 316 SS; shaft: Tungsten carbide standard or 316 SS optional; bearing: PTFE standard.
Linearity: ±1.0% of FS.
Repeatability: ±0.5% of FS.
Temperature Limits: -40 to 212°F (-40 to 100°C).
Pressure Limits: 400 psig (27.6 bar) @ 100°F (37.8°C), 325 psig (22.4 bar) @ 212°F (100°C).
Process Connection: 1-1/2" NPT male or 1-1/2" BSPT male standard, 2" NPT male or 2" BSPT male optional.
Output: Pulse: NPN open collector with square wave output, rated 60 V @ 50 mA max; Frequency: 3.2 to 200 Hz. Pulse Width: 2.5 msec ±25%; 4-20 mA: 4 mA is 0 ft/s, 20 mA is 25 ft/s.
Power Requirement: 10-35 VDC.
Power Consumption: 40 mA (max.).
Electrical Connection: 22 AWG shielded UL type PTLC rated 105°C, 20' (6.1 m) long with cable gland. Can be extended up to 2000' (609 m) with similar cable. Optional UL listed burial rated cable.
Enclosure Rating: NEMA 6P (IP67)*.
Housing Materials: Brass or 316 SS.
Weight: 3 lb (1.36 kg).
Agency Approvals: CE.

*Brass units IP67 only.

MODEL CHART										
Example	PFT	-I	D	N	-B	1	1	-S	-ST	PFT-IDN-B111-S-ST
Series	PFT									Paddlewheel flow sensor
Style		I H								Insertion Hot-tap insertion
Output			D A							600UA/40 MA 2.5 MS pulse Analog 4-20 mA transmitter
Approvals				N						None
Body Material					B S					Brass body 316 SST body
Mounting						1 2 3 4 5 6 7 8				1-1/2" NPTM mounting 2" NPTM mounting 1-1/2" male BSPT mounting 2" male BSPT mounting 1-1/2" NPTM hot top with valve 1-1/2" BSPT hot tap without valve 1-1/2" BSPT hot tap with valve 1-1/2" BSPT hot tap without valve
O-Ring Material							1 2 3			FKM fluoroelastomer Silicone (FDA approved) Buna-N
Wetted Materials								1 2		Tungsten-carbide shaft, 316 SS impeller, PTFE bearing 316 SS shaft, 316 SS impeller, PTFE bearing
Electrical Connection								S B		22 GA shielded wire, 20 ft (6.1 m) 18 GA UL listed burial rated, 4 ft (1.2 m)
Options									ST	Stainless steel tag

ACCESSORIES	
Model	Description
A-PFT-HKIT	1-1/2" Brass valve NPT with nipple
A-PFT-HKIT-SS	1-1/2" SS valve NPT with nipple
A-PFT-HKIT-BSPT	1-1/2" Brass valve BSPT with nipple
A-PFT-HKIT-SS-BSPT	1-1/2" SS valve BSPT with nipple

USA: California Proposition 65
 ⚠️WARNING: Cancer and Reproductive Harm - www.P65Warnings.ca.gov

MULTI-JET HOT WATER METER

High Temperature Threshold, Pulsed Output

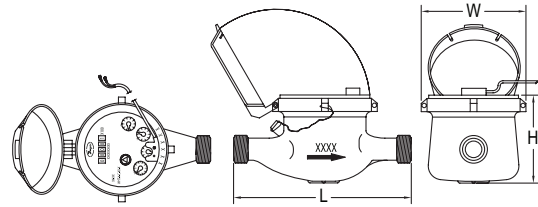

Size in (mm)	Spud NPSM (BSPP)	Length 'L' in (mm)	Width 'W' in (mm)	Height 'H' in (mm)	Weight lb (kg)
5/8 x 1/2 (15)	3/4" (3/4")	6-1/2(165)	3-45/64 (94)	4-15/64(107.5)	3.75(1.7)
5/8 x 3/4	1" (1")	7-1/2(190)	3-45/64(94)	4-15/64(107.5)	3.97(1.8)
3/4 (20)	1" (1")	7-1/2(190)	3-45/64(94)	4-15/64(107.5)	4.9(2.2)
1 (25)	1-1/4" (1-1/4")	10-1/4(260)	3-55/64(98)	4-5/8(117.5)	6.4(2.9)
1-1/4 (32)	1-1/2" (1-1/2")	10-1/4 (260)	3-55/64(98)	4-5/8(117.5)	8.2(3.7)
1-1/2 (40)	2" (2")	11-13/16 (300)	4-51/64(122)	5-9/16(141.5)	13.52 (6.17)
2 (50)	2-1/2" (2-1/2")	11-13/16 (300)	5-45/64(145)	6-31/32(177)	18.74 (8.5)

The Series WMH Multi-Jet Hot Water Meter is a series of mechanical, water totalizing meters that display the total water usage in gallons with m³ options. They are available in a range of body sizes and include NPT or BSPT optional couplings. The high temperature resistant brass body is compatible in applications with high temperature water not suitable with standard brass water meters and maintains its accuracy.

FEATURES/BENEFITS

- High temperature threshold of 190°F (88°C) ideal for high temperature applications
- Multi-jet design allows for simplicity and accuracy with wide flow ranges, even in low flow applications
- Magnetically driven, hermetically sealed register does not leak or fog and is completely separated from the water
- Designed for long service life and maintenance-free operation
- Integral strainer that protects meter from particulate damage
- Easy installation with included coupling adapters
- Pulsed output proportional to flow allows for remote flow totalization

APPLICATIONS

- HVAC applications
- Measuring total condenser water flow in residential, commercial and industrial applications
- Remote hot water monitoring

SPECIFICATIONS

Service: Water.
Wetted Materials: Body: Brass; Couplings: Brass; Measuring Chamber: Brass.
Flow Range: See model chart.
Accuracy: WMH-A-X-XX: Transitional Flow: ±3%; Nominal Flow: ±1.5%.
Temperature Limit: 190°F (88°C).
Pressure Limit: 150 psi (10 bar).
Totalizing Display Maximum: See model chart.

Output Signal: Pulse output with frequency proportional to flow rate.
Pulse Options: 0.1 gal, 1 gal, 10 gal, 100 gal per pulse (1 L, 10 L, 100 L, 1000 per pulse) See model chart.*
Electrical Rating: 0.01A @ 24VAC/DC.
Electrical Connections: Color-coded lead wires, 4.5' (1.5 m) long.
Mounting Orientation: Horizontal with register facing up.
Weight: See dimension chart.

*Consult factory for m³, BSPT units or additional pulse output options

MODEL CHART

Model	Size	Coupling Size	GPM (Gallons Per Minute)			Display Max (Gallons)	Pulse Rate (Gal/Pulse)
			Max Flow	Nominal Flow Range	Transitional Flow		
WMH-A-C-01	5/8" x 1/2"	1/2" NPT	20	1 to 20	0.25	9,999,999.99	0.1
WMH-A-C-02	5/8" x 3/4"	3/4" NPT	20	1 to 20	0.25	9,999,999.99	0.1
WMH-A-C-03	3/4" SL	3/4" NPT	30	2 to 30	0.5	9,999,999.99	0.1
WMH-A-C-06	1"	1" NPT	50	3 to 50	0.75	9,999,999.99	0.1
WMH-A-C-01-1	5/8" x 1/2"	1/2" NPT	20	1 to 20	0.25	9,999,999.99	1
WMH-A-C-02-1	5/8" x 3/4"	3/4" NPT	20	1 to 20	0.25	9,999,999.99	1
WMH-A-C-03-1	3/4" SL	3/4" NPT	30	2 to 30	0.5	9,999,999.99	1
WMH-A-C-06-1	1"	1" NPT	50	3 to 50	0.75	9,999,999.99	1
WMH-A-C-07-1	1-1/2"	1-1/2" NPT	100	5 to 100	1.5	9,999,999.9	1
WMH-A-C-08-1	2"	2" NPT	160	8 to 160	2	9,999,999.9	1
WMH-A-C-01-10	5/8" x 1/2"	1/2" NPT	20	1 to 20	0.25	9,999,999.99	10
WMH-A-C-02-10	5/8" x 3/4"	3/4" NPT	20	1 to 20	0.25	9,999,999.99	10
WMH-A-C-03-10	3/4" SL	3/4" NPT	30	2 to 30	0.5	9,999,999.99	10
WMH-A-C-06-10	1"	1" NPT	50	3 to 50	0.75	9,999,999.99	10
WMH-A-C-07-10	1-1/2"	1-1/2" NPT	100	5 to 100	1.5	9,999,999.9	10
WMH-A-C-08-10	2"	2" NPT	160	8 to 160	2	9,999,999.9	10

USA: California Proposition 65

⚠WARNING: Cancer and Reproductive Harm
www.P65Warnings.ca.gov

SERIES WNT

MULTI-JET BRASS BODY WATER METER

NSF Certified, Lead Free, Economical

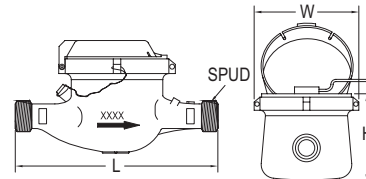

Size in (mm)	Spud NPSM (BSPP)	Length 'L' in (mm)	Width 'W' in (mm)	Height 'H' in (mm)	Weight lb (kg)
5/8 x 1/2 (15)	3/4" (3/4")	7-31/64(190)	3-45/64 (94)	4-15/64 (107.5)	3.58 (1.63)
5/8 x 3/4 (15)	1" (1")	7-31/64(190)	3-45/64(94)	4-15/64 (107.5)	3.81 (1.73)
3/4 (20)	1" (1")	10-1/4 (260)	3-55/64 (98)	4-5/8 (117.5)	6.02 (2.73)
1 (25)	1-1/4" (1-1/4")	10-1/4(260)	3-55/64 (98)	4-5/8 (117.5)	6.02 (2.73)
1-1/2 (40)	2" (2")	11-13/16 (300)	4-51/64 (122)	4-5/8 (117.5)	12.02 (5.45)
2 (50)	2-1/2" (2-1/2")	11-13/16 (300)	5-45/64 (145)	5-9/16 (141.5)	13.23 (6)

The Series WNT Multi-Jet Brass Body Water Meter is a series of mechanical, water totalizing meters that display the total water usage in gallons or cubic meter. They are available in a range of body sizes and include NPT or BSPT couplings. Its lead free, NSF certified body is ideal for potable water applications.

FEATURES/BENEFITS

- NSF/ANSI makes it ideal for no lead portable water requirements
- Multi-jet design allows for simplicity and accuracy with wide flow ranges, even in low flow applications
- Magnetically driven, hermetically sealed register does not leak or fog and is completely separated from the water
- Designed for long service life and maintenance-free operation
- Integral strainer that protects meter from particulate damage
- Easy installation with included coupling adapters
- Pulsed output proportional to flow allows for remote flow totalization

APPLICATIONS

- Potable water applications
- Residential water measurement
- Remote water monitoring

SPECIFICATIONS

Service: Water.
Wetted Materials: Body: ECO BRASS®; Couplings: ECO BRASS®; Measuring chamber: ABS Plastic.
Flow Range: See model chart.
Accuracy: Transitional Flow: ±3%; Nominal Flow: ±1.5%.
Temperature Limit: 122°F (50° C).
Pressure Limit: 150 psi (10 bar).
Totalizing Display Maximum: See model chart.

Output Signal: Pulse output with frequency proportional to flow rate.
Pulse Options: 0.1 gal, 1 gal, 10 gal, 100 gal per pulse.
Electrical Rating: 0.01 A @ 24 VAC/DC.
Electrical Connections: Color-coded lead wires, 4.5' (1.5 m) long.
Mounting Orientation: Horizontal with register facing up.
Weight: See dimension chart.
Agency Approvals: NSF.

MODEL CHART

Model	Size	Coupling Size	GPM (Gallons Per Minute)			Display Max (Gallons)	Pulse Rate (Gal/Pulse)
			Max Flow	Nominal Flow Range	Transitional Flow		
WNT-A-C-01	5/8" x 1/2"	1/2" NPT	20	1 to 20	0.25	9,999,999.99	0.1
WNT-A-C-02	5/8" x 3/4"	3/4" NPT	20	1 to 20	0.25	9,999,999.99	0.1
WNT-A-C-05	3/4" x 1"	1" NPT	30	2 to 30	0.5	9,999,999.99	0.1
WNT-A-C-06	1"	1" NPT	50	3 to 50	0.75	9,999,999.99	0.1
WNT-A-C-07-1	1-1/2"	1-1/2" NPT	100	5 to 100	1.25	9,999,999.9	1
WNT-A-C-08-1	2"	2" NPT	160	8 to 160	2	9,999,999.9	1

USA: California Proposition 65

⚠WARNING: Cancer and Reproductive Harm - www.P65Warnings.ca.gov

ECO BRASS® is a registered trademark patent by Mitsubishi Shindoh

ULTRASONIC FLOWMETER SETS

Non-Invasive Pipe Flow Measurement, Easy Operation and Data Logging Option



UFB



UFC

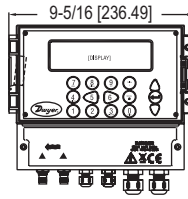

UFB

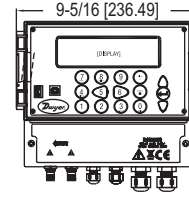

UFC

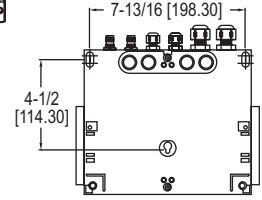
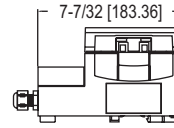
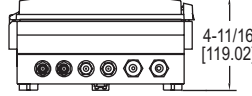

The Series UFB & UFC Ultrasonic Flowmeter Sets utilize the transit-time difference for measuring flow rates in pipes. These units are permanent mount, where the converters can be mounted on a surface or pipe with a 4-20 mA and pulse output capabilities for pipe sizes from 1/2 to 79" (13 to 2000 mm). The Series UFC offers the same features plus data logging capability.

FEATURES/BENEFITS

- Non-invasive pipe measurement
- Easy-to-use compact and lightweight design, intended for homogeneous liquids that contain no air
- Simple installation with all necessary components included such as converter, sensor, cables and mounting accessories
- Sturdy IP65 rating, protecting it from dust and direct water contact

APPLICATIONS

- Water treatment
- Industrial systems
- Irrigation applications
- Treated water flow
- River water
- Sea water
- Potable water
- Demineralized water
- Glycol/water mix
- Hydraulic system
- Diesel oil
- Water use data logging

KIT INCLUDES

- Converter
- Set of transducers
- Ruled guide rail
- Steel banding
- Banding clips
- Set of transducer cables
- Set of high temperature interface cables
- Ultrasonic coupling grease

MODEL CHART - STANDARD VERSION		
Model	Pipe Size Range in (mm)	Power Supply
UFB-122	0.5 to 4.5 (13 to 115)	86-264 VAC
UFB-123	2 to 79 (50 to 2000)	86-264 VAC
UFB-222	0.5 to 4.5 (13 to 115)	24 VAC/VDC
UFB-223	2 to 79 (50 to 2000)	24 VAC/VDC

MODEL CHART - DATA LOGGING VERSION		
Model	Pipe Size Range in (mm)	Power Supply
UFC-122	0.5 to 4.5 (13 to 115)	86-264 VAC
UFC-123	2 to 79 (50 to 2000)	86-264 VAC
UFC-222	0.5 to 4.5 (13 to 115)	24 VDC/VAC
UFC-223	2 to 79 (50 to 2000)	24 VDC/VAC

SPECIFICATIONS

Service: Homogeneous liquids that do not contain more than 3% of air bubbles or particulate and capable of ultrasonic wave propagation.
Inputs: TNC cable from sensors.
Range: 0.33 to 33 ft/s (0.1 to 10 m/s).
Display: 240 x 64 pixel graphic display, high contrast black on white with backlight; Languages: English, French, German, Swedish, Italian, Spanish, Portuguese, Russian, Norwegian, and Dutch; 5" W x 1.3" H (5 x 33.02 mm).
Accuracy: ±0.5 to ±2% of flow reading of flow rate > 0.03 ft/s (0.01 m/s) and pipe OD > 3.0 in (75 mm); ±3% of flow reading for flow rate > 0.03 ft/s (0.01 m/s) and pipe OD 0.5 to 3 in (13 to 75 mm); ±6% of flow reading for flow rate < 0.03 ft/s (0.01 m/s).
Power Requirements: 86-264 VAC (50 to 60 Hz) or 24 VAC/VDC (1 A max).
Power Consumption: 10.5 W.
Temperature Limits: Transducer: -4 to 275°F (-20 to 135°C); Controller: -4 to 122°F (-20 to 50°C).
Outputs: Analog 1 opto-isolated output: 4-20 mA, 0-16 mA or 0-20 mA (selectable); Error current: 0-26 mA (selectable); Load resistance: 620 Ω max; Alarm: 2 opto-isolated MOSFET NO relays, 48 V at 500 mA, maximum 200 Hz; Pulsed: 1 opto-isolated MOSFET relay, 48 V at 500 mA, 1 to 250 pps; Pulse width: 2 to 500 ms (selectable).
Serial Communications: USB (UFC only).
Enclosure Rating: IP65 when using TNC connector; Transducers IP54.
Materials: Plastic ABS and aluminum.
Repeatability: ±0.5 % of measured value or 0.03 ft/s (0.01 m/s).
Electrical Connections: Removable screw-in type terminal block.
Mounting: Wall mounted using 3 type M4 screws.
Turbidity: < 3 % by volume of particulate content.
Permissible Air Content: < 3% by volume.
Response Time: < 500 ms.
Weight: Unit not including accessories: 2.80 lb (1.26 kg); Unit including accessories: 9.92 lb (4.5 kg).
Agency Approvals: CE.

ADDITIONAL SPECIFICATIONS

Applicable Pipe Material: Carbon steel, SS, copper, UPVC/PVDF, concrete, mild steel, glass, brass.
Applicable Pipe Lining: Rubber, glass, concrete, epoxy, steel, other*.
Pipe Wall Thickness: 0.04 to 3" (1 to 75 mm).
Pipe Lining Thickness: < 1" (< 25 mm).

*Selectable option for special material with known propagation rate of lining material.

OPTIONS	
Use order code:	Description
NISTCAL-FU	NIST traceable calibration certificate

USA: California Proposition 65
 ⚠WARNING: Cancer and Reproductive Harm - www.P65Warnings.ca.gov

COMPACT ULTRASONIC FLOWMETERS

Cost Effective, Compact and Adjustable Design, Non-Invasive

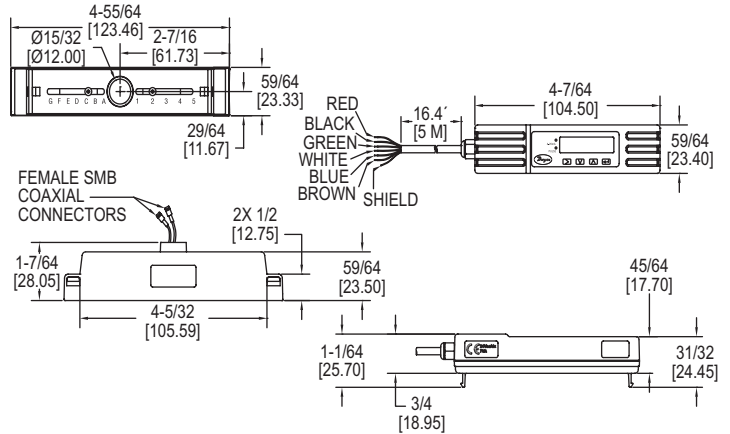

The **Model UFM Compact Ultrasonic Flowmeters** are economical, clamp-on, ultrasonic flowmeter. The Model UFM implements the transit-time difference to measure flow rates in pipes and can measure velocity and flow in pipes with outside diameters ranging from 0.98 to 4.62" (24.89 to 117.35 mm). This model comes with a volume pulse and 4-20 mA flow rate output.

FEATURES/BENEFITS

- Non-invasive pipe measurement
- Simple installation with all necessary components included such as converter, sensor, cables and mounting accessories
- Compact and lightweight design, featuring an easily installed, all in one clamp-on unit intended for homogeneous liquids that contain no air
- Screen offers easy to read text displaying both flow rate and total with a convenient backlight for visual comfort

APPLICATIONS

- Flow measurement for heat metering
- Chilled water metering and monitoring
- Potable water metering and monitoring
- Process water metering and monitoring

KIT INCLUDES

- Converter with adjustable guiderail
- Set of 1.81 to 2.75" (46 to 70 mm) clamps
- Set of 2 to 5" (51 to 127 mm) clamps
- Set of small pipe adaptor circle clamps
- Set of small pipe adaptor V clamps
- Ultrasonic coupling grease

MODEL CHART	
Model	Description
UFM-1	Compact ultrasonic flowmeter

SPECIFICATIONS	
Service: Clean water with < 3% by volume of particulate content.	Enclosure Rating: IP54.
Range: 0.33 to 32.8 ft/s (0.1 to 10 m/s).	Enclosure Material: Plastic polycarbonate.
Display: Backlit: 3.27" H x 0.74" W (83.1 mm x 18.8 mm), 2 line x 16 characters.	Repeatability: ±0.5% of measured value.
Accuracy: ±3% of flow reading for > 0.98 ft/s (> 0.3 m/s).	Electrical Connections: 16.4' (5 m) cable.
Power Requirements: 12-24 VDC or VAC.	Response Time: < 1 s.
Power Consumption: 7 W max.	Weight: 2.9 lb (1.315 kg).
Temperature Limits: Process: 32 to 185°F (0 to 85°C); Ambient: 32 to 122°F (0 to 50°C).	Agency Approvals: CE.
Outputs: Analog: 1 opto-isolated: 4 to 20 mA; Error current: 3.5 mA; Load resistance: 620 Ω max; Pulse: 1 opto-isolated MOSFET relay, 500 mA max, 166 pps max, 200 Hz max.	ADDITIONAL SPECIFICATIONS
	Applicable Pipe Material: Steel, copper, or plastic.
	Pipe Outside Diameter: 0.98 to 4.62" (24.89 to 117.35 mm).
	Applicable Pipe Lining: None.
	Pipe Wall Thickness: 0.02 to 0.39" (0.5 to 10 mm).

OPTIONS	
Use order code:	Description
NISTCAL-FU	NIST traceable calibration certificate

USA: California Proposition 65

⚠WARNING: Cancer and Reproductive Harm - www.P65Warnings.ca.gov

MODEL UTG

ULTRASONIC THICKNESS GAGE

Ideal For Use with Ultrasonic Flow Transmitters, Adjustable Sound Velocity

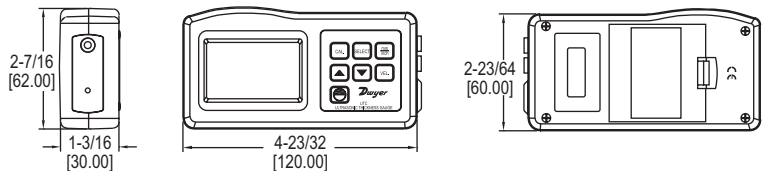

The **Model UTG Ultrasonic Thickness Gage** measures the thickness of a variety of materials. The UTG works on a variety of parallel surface material ranging from 0.05 to 7.9" (1.2 to 200 mm).

FEATURES/BENEFITS

- Non-invasive thickness measurement
- Reads in inches or millimeters and features an adjustable sound velocity to allow for an array of materials to be measured
- Allows the user to find the wall thickness of the pipe when programming an ultrasonic transmitter without cutting or removing a section of the pipe to measure it
- Ideal for monitoring corrosion in closed vessels such as boilers and chemical tanks and with any ultrasonic flow transmitter

APPLICATIONS

- Pipe thickness measurement
- Finding wall thickness
- Monitoring corrosion in closed vessels
- Industrial applications
- Automotive
- HVAC
- Plumbing

SPECIFICATIONS	
Service: Steel, cast iron, aluminum, red copper, brass, zinc, quartz glass, polyethylene, PVC, gray cast iron, nodular cast iron, other. Selectable option for special materials with known sound propagation rate.*	Sound Velocity: 1118 to 20132 mph (500 to 9000 m/s).
Range: 0.047 to 7.874" (1.2 to 200 mm).	Temperature Limits: 32 to 122°F (0 to 50°C).
Accuracy: ±0.5%.	Humidity Limit: < 80%.
Resolution: 0.001" / 0.1 mm.	Display: 4 digits, 0.394" (10 mm) LCD.
	Power Requirement: (4) 1.5 V AAA alkaline batteries, not included, user replaceable.
	Weight: 5.78 oz (164 g).

*Material must be uniform with minimal coating/paint.

MODEL CHART	
Model	Description
UTG	Ultrasonic thickness gage

USA: California Proposition 65

⚠WARNING: Cancer and Reproductive Harm - www.P65Warnings.ca.gov

VANE FLOW SWITCH

Low Cost, Field Adjustable Set Point and Paddle

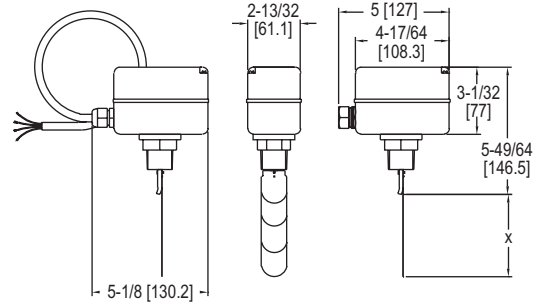

Shown with conduit connection option

The Series FS-2 Vane Flow Switch offers an economical flow proving solution. The FS-2 paddles are adjustable to fit 1 to 8" size pipe.

FEATURES/BENEFITS

- Field adjustable set point adjustment screw allows for easy flow switch modification
- Custom application set points enabled by field adjustable vane layers
- Aluminum weatherproof housing permits outdoor installation

APPLICATIONS

- Boiler flow proving
- Hot water heaters
- Chillers
- Cooling lines
- Machinery
- Liquid transfer systems

SPECIFICATIONS

Service: Compatible liquids.
Wetted Materials: Bellow: Tin-bronze; Vane: SS; Body: Forged brass.
Temperature Limit: 230°F (110°C).
Pressure Limit: 145 psig (10 bar).
Enclosure Rating: NEMA 4 (IP64).
Switch Type: SPDT snap switch.
Electrical Rating: 10 A res, 3 A ind @ 250 VAC.
Electrical Connection: Cable gland with attached wire leads or optional conduit connection.
Process Connection: 1" male NPT or BSPT.
Mounting Orientation: Switch must be installed vertically on horizontal pipe runs.
Set Point Adjustment: Four vane combinations and an adjustment screw.
Enclosure: Die-cast aluminum alloy.
Weight: 28.22 oz (0.8 kg).
Agency Approvals: CE.

MODEL CHART	
Model	Description
FS-2	Paddle flow switch

OPTIONS	
To order add suffix:	Description
-BSPT	Process connection
Example: FS-2-BSPT	
-CND	Conduit connection, 1" NPT female conduit connection with no wire leads.
Example: FS-2-CND	

APPROXIMATE ACTUATION/DEACTUATION FLOW RATES FOR WATER; GPM (LPM)

Pipe Size	Blade Vane Length in (mm) Dim. X	Minimum Setting		Maximum Setting	
		Actuate	Deactuate	Actuate	Deactuate
1"	1.34 (34)	4.0 (15.0)	1.8 (6.7)	8.8 (33.3)	6.6 (25.0)
1-1/4"	1.34 (34)	5.3 (20.0)	2.6 (10.0)	11.4 (43.3)	8.4 (31.7)
1-1/2"	2.24 (57)	7.0 (26.7)	4.0 (15.0)	14.5 (55.0)	11.4 (43.3)
2"	2.24 (57)	14.1 (53.3)	9.7 (36.7)	31.3 (118.3)	22.5 (85.0)
2-1/2"	3.46 (88)	18.5 (70.0)	15.4 (58.3)	35.2 (133.3)	30.8 (116.7)
3"	3.46 (88)	27.7 (105.0)	25.1 (95.0)	52.8 (200.0)	46.2 (175.0)
4"	3.46 (88)	59.4 (225.0)	52.8 (200.0)	123.3 (466.7)	114.5 (433.3)
5"	6.57 (167)	52.8 (200.0)	39.6 (150.0)	132.1 (500.0)	123.3 (466.7)
6"	6.57 (167)	75.7 (286.7)	52.8 (200.0)	154.1 (583.3)	140.9 (533.3)
8"	6.57 (167)	184.9 (700.0)	158.5 (600.0)	396.3 (1500.0)	374.2 (1416.7)

FLOTECT® VANE OPERATED FLOW SWITCH

Magnetic Linkage, UL Approved

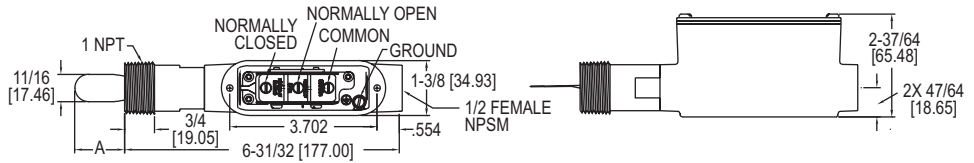

Pipe Size	Dim. A	Pipe Size	Dim. A
1	1-17/64 [32.15]	2	2-11/64 [55.17]
1-1/4	1-19/32 [40.48]	3	2-11/64 [55.17]
1-1/2	1-53/64 [46.43]	4	2-11/64 [55.17]

The Series V7 Flotect® Vane Flow Switch is an inexpensive range switch for use with compatible liquids to start or stop electronic operated equipment when flow or no-flow conditions occur. Design is standard weatherproof, meeting NEMA 4X.

FEATURES/BENEFITS

- Magnetically actuated switching design gives superior performance
- Features a free-swinging vane which attracts a magnet within the solid metal switch body, actuating a snap switch by means of a simple lever arm with no bellows, springs, or seals to fail
- Lower body is machined solid metal bar stock assuring no leak points, no matter how long the unit is in service
- Robust vane design is rigid and field trimmable for set point adjustment

APPLICATIONS

- Proof of boiler flow
- Shuts down burner when air flow through heating coil fails
- Protects pumps, motors and other equipment against low or no flow
- Stops liquid cooled engines, machines and processing when coolant flow is interrupted

APPROXIMATE ACTUATION/DEACTUATION FLOW RATES FOR COLD WATER; GPM (LPM)		
Pipe Size	Actuate	Deactuate
1"	7.5 (28.4)	6.8 (25.7)
1-1/4"	8.1 (30.8)	7.6 (28.9)
1-1/2"	11.7 (44.1)	10.9 (41.3)
2"	16.9 (64.0)	15.6 (59.1)
2-1/2"	19.6 (74.2)	18.1 (68.5)
3"	31.6 (120)	29.6 (112)
4"	58.0 (218)	52.0 (197)

Contact the factory for different actuation-deactuation rates.

SPECIFICATIONS

Service: Liquids compatible with wetted materials that are non-coating and non-crystallizing.
Wetted Materials: Vane: 301 SS; Process connection: Brass or 316 SS; Magnet: Ceramic; Other: 301, 302 SS.
Upper Body Material: Die cast aluminum.
Temperature Limits: -40 to 250°F (-40 to 121°C).
Pressure Limits: 250 psi (17.2 bar).
Enclosure Rating: Weatherproof, meets NEMA 4X (IP66).
Switch Type: SPDT snap switch.
Electrical Rating: 10 A @ 125, 250, 480 VAC; 1/8 hp @ 125 VAC, 1/4 hp @ 250 VAC.

Electrical Connections: 3 screw type, common, normally open and normally closed.
Conduit Connection: 1/2" NPSM.
Process Connection: 1" male NPT. Contact factory for optional tees.
Pipe Size: 1" to 4".
Mounting Orientation: Horizontal or vertical (actuation flow rates are based on horizontal pipe runs in the vertical position). Will not work in vertical pipe with down flow.
Set Point Adjustment: Vane is trimmable, see set point chart.
Weight: 1 lb 2 oz (500 g).
Agency Approvals: CE, UL.

MODEL CHART

Model	Body Material
V7-WBS-30N	Brass
V7-WSS-30N	316 SS

USA: California Proposition 65

⚠WARNING: Cancer and Reproductive Harm - www.P65Warnings.ca.gov

SERIES V10 | W. E. ANDERSON™ BY DWYER

FLOTECT® MINI-SIZE FLOW SWITCH

Proof of Flow or No Flow in 1/2 to 2" Pipe, Cost Effective, Leak Proof Body, Weatherproof

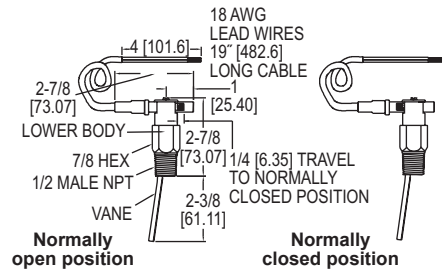

The Series V10 Flotect® Mini-Size Flow Switch is designed to provide inexpensive, reliable monitoring of the presence or absence of flow in a system. This series is available for field installation in pipelines from 1/2 to 2" diameter and available in brass or 303 SS body.

FEATURES/BENEFITS

- Magnetically actuated switching design gives superior performance with rugged, hermetically sealed reed switch
- Simple field switch adjustment allows user to toggle between Normally Open (NO) or Normally Closed (NC) with no change in the electrical connection
- Switch housing is located outside the process media, allowing simple switch change-over or maintenance without interruption of process flow
- Full size, field trimmable stainless steel vane provided with removable template calibrated for brass or ductile iron reducing tees with forged steel straight tee/bushing combinations

APPLICATIONS

- Proving flow in boilers, hot water heaters, and chillers
- Protects pumps, motors and other equipment against low or no flow
- Automatically starts auxiliary pumps and engines

APPROXIMATE ACTUATION/DEACTUATION FLOW RATES FOR COLD WATER; GPM (LPM)				APPROXIMATE ACTUATION/DEACTUATION FLOW RATES FOR AIR; SCFM (LPM)			
Pipe Size	Trim	N.O.	N.C.	Pipe Size	Trim	N.O.	N.C.
1/2"	L	2.6/2.3 (9.8/8.7)	2.6/2.5 (9.8/9.5)	1/2"	L	10.3/8.8 (291.7/250)	10.2/9.2 (288/260)
3/4"	J	3.1/2.7 (11.7/10.2)	3.1/2.8 (11.7/10.6)	3/4"	J	13/11.6 (368.3/328)	12.9/11.6 (365/328)
1"	H	4.8/4.5 (18.2/17)	4.8/4.4 (18.2/16.7)	1"	H	19.2/17.6 (543.3/498)	18.9/17.6 (535/498)
1-1/4"	E	6.2/5.6 (23.5/21.2)	6.1/5.6 (23.1/21.2)	1-1/4"	E	24.8/22.2 (701.7/628)	24.5/22.5 (693/637)
1-1/2"	C	8.2/7.7 (31/29.1)	8.2/7.7 (31/29.1)	1-1/2"	C	33.4/31.2 (946.7/883)	33/30.6 (935/867)
2"	Full	9.5/9.1 (36/34.4)	9.5/9 (36/34.1)	2"	Full	50.2/48.4 (1422/1370)	50.2/47.7 (1422/1352)

SPECIFICATIONS

Service: Compatible gases or liquids.
Wetted Materials: Vane: 301 SS; Body: Brass or 303 SS; Pin and Magnet: Ceramic 8.
Temperature Limit: 200°F (93°C).
Pressure Limit: Brass body: 1000 psig (69 bar); 303 SS body: 2000 psig (138 bar).
Enclosure Rating: Weatherproof, meets NEMA 4X (IP66).
Switch Type: SPST hermetically sealed reed switch. Field adjustable for normally open or normally closed.
Electrical Rating: 0.5 A @ 120 VAC; 1.5 A @ 24 VDC res.; 0.001 A @ 200 VDC res.

Electrical Connections: 18 AWG, 19" (483 mm) long, PVC jacket. Rated 221°F (105°C).
Process Connection: 1/2" male NPT or 1/2" male BSPT.
Mounting Orientation: Switch can be installed in any position but the actuation/deactuation flow rates are based on horizontal pipe runs and are nominal values.
Set Point Adjustment: Vane is trimmable.
Weight: 5.5 oz (0.16 kg).
Agency Approvals: CE, CSA, UR.
Switch Enclosure: Nylon.

MODEL CHART

Model	Body Material	Connection Type	Switch Configuration
V10	Brass	NPT	Normally open or closed
V10SS	303 SS	NPT	Normally open or closed
V10-BSPT	Brass	BSPT	Normally open or closed
V10SS-BSPT	303 SS	BSPT	Normally open or closed

USA: California Proposition 65

⚠WARNING: Cancer and Reproductive Harm - www.P65Warnings.ca.gov

FLOTECT® VANE OPERATED FLOW SWITCHES

Field Adjustable — 1 to 6 Inch Pipe, Leak Proof Body, Chemical Resistance

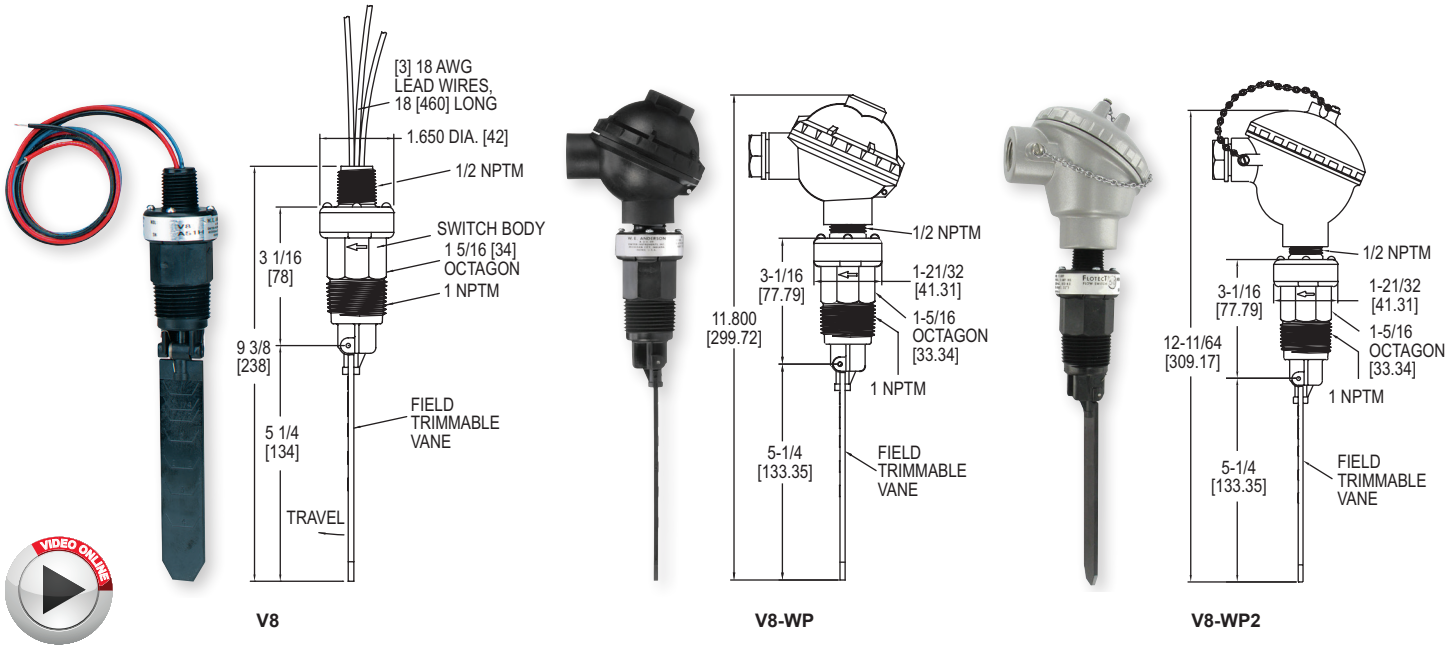

The Series V8 FloTECT® Vane Operated Flow Switches are ideal for protecting unattended equipment from damage or loss of production. This Series is available for installation in a 1 to 6" pipe with operating pressures are up to 150 psig (10 bar) and temperatures to 212°F (100°C).

FEATURES/BENEFITS

- UL recognized as an industrial motor controller per UL standard 508, suitable for mounting in a protected environment
- Magnetically actuated switching design gives superior performance with free-swinging vane which attracts a magnet within the switch body, actuating a snap switch with no bellows, springs, or seals to fail
- Leak proof body and vane constructed of tough durable polyphenylene sulfide which has excellent chemical resistance
- A full size trimmable vane is provided with molded-in graduations

APPLICATIONS

- Chemical processing
- Air conditioning
- Refrigeration
- Heating systems
- Cooling lines
- Machinery
- Liquid transfer systems
- Water treatment
- Food processing
- Machine tools

APPROXIMATE ACTUATION/DEACTUATION FLOW RATES FOR COLD WATER; GPM (LPM)	
Pipe Size	Actuate/Deactuate
1"	10.8/9.1 (40.9/34.6)
1-1/4"	9.8/8.3 (37.2/31.4)
1-1/2"	8.6/6.8 (32.4/25.7)
2"	10.9/8.8 (41.2/33.4)
3"	12.9/8.9 (48.8/33.5)
4"	21.1/13.8 (79.7/52.2)
6"	45/33 (170.2/124.7)

APPROXIMATE ACTUATION/DEACTUATION FLOW RATES FOR AIR; SCFM (LPM)	
Pipe Size	Actuate/Deactuate
1"	39/32.6 (1105/923)
1-1/4"	37.5/32.2 (1062/912)
1-1/2"	33.4/26.7 (945/757)
2"	43/36.8 (1218/1042)
3"	52.7/38.9 (1493/1100)
4"	87.6/63.6 (2482/1802)
6"	168.6/137.4 (4775/3890)

SPECIFICATIONS

Service: Compatible gases or liquids.
Wetted Materials: Vane and body: Polyphenylene Sulfide (PPS); Pin and spring: 316 SS or Inconel®; Magnet: Ceramic 8.
Temperature Limit: 212°F (100°C).
Pressure Limit: 150 psig (10.34 bar).
Enclosure Rating: General purpose, WP/WP2 option is weatherproof.
Switch Type: SPDT snap switch, MV option: SPDT gold contact snap switch.
Electrical Rating: 5 A @ 125/250 VAC, 5 A resistive, 3 A inductive @ 30 VDC; MV option: 1 A @ 125 VAC, 1 A resistive, 0.5 A inductive @ 30 VDC.
Electrical Connections: 18 AWG, 18" (460 mm) long.
Conduit Connection: 1/2" male NPT, 1/2" female NPT on WP and WP2.
Process Connection: 1" male NPT.
Mounting Orientation: Actuation/deactuation flow rates are based on horizontal pipe runs and are nominal values. Unit cannot be used with vertical down flow.
Set Point Adjustment: Vane is trimmable.
Weight: 4.5 oz (0.13 kg).
Agency Approvals: CE, cURus.

MODEL CHART

Model	Description
V8	Flow switch

OPTIONS

To order add suffix:	Description
-MV	Gold plated contacts, for dry circuits; rated 1A @ 125 VAC; 1A resistive, 0.5A inductive @ 30 VDC
Example: V8-MV	
-INC	Inconel® alloy option; Inconel® alloy replaces standard 316 SS wetted parts; wetted parts are Inconel® alloy, ceramic 8, and polyphenylene sulfide
Example: V8-INC	
-WP	Weatherproof enclosure; optional housing is phenylpolioxide and provides weatherproof protection for electrical wiring; not UL approved
Example: V8-WP	
-WP2	Optional housing is aluminum and provides weatherproof protection for electrical wiring; not UL approved
Example: V8-WP2	

Inconel® is a registered trademark of Huntington Alloys Corporation

WATER LEAK DETECTORS

Battery or External Powered, SPST or DPDT Relays



WD3-BP



WD3-LP



Bracket

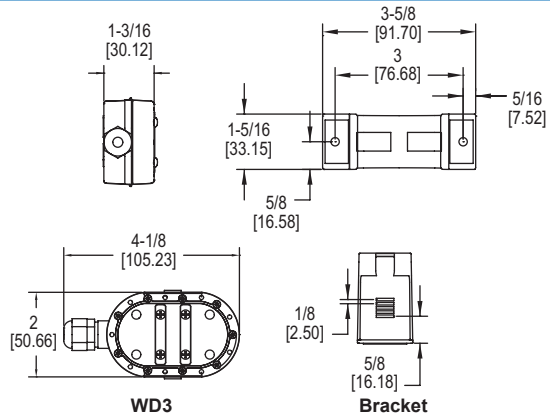

The **Series WD3 Water Leak Detectors** protect equipment from water damage by detecting the presence of water. Model WD3-BP-D1-A is battery powered, all others require AC or DC supply voltages.

FEATURES/BENEFITS

- Audible and visual alerts provide local indication of the alarm condition and internal switch will give remote indication or control to prevent further buildup of water
- Sensing height can be adjusted as low as 1/32" (0.79 mm) using the included adjustable mounting bracket
- Mounting bracket can attach to any flat surface by either using the attached adhesive strips or mounting screws for easy installation

APPLICATIONS

- AHU drip pans
- Radiant floors
- Data centers
- Sump pumps
- Drains

MODEL CHART

Model	Output	Power	Audible Alarm
WD3-BP-D1-A	SPST NO SSR	Battery	Yes
WD3-LP-D2	DPDT relay	24 VAC (±10%) or 11-27 VDC	No
WD3-LP-D2-A	DPDT relay	24 VAC (±10%) or 11-27 VDC	Yes

SPECIFICATIONS

Service: Water or conductive fluids.
Minimum Sensing Gap: 1/32".
Switch Type: Battery powered model: SPST NO SSR; External powered models: DPDT relay.
Electrical Ratings: Battery powered model: Pilot duty rating 250 mA @ 24 VDC; External powered models: 1 A @ 24 VAC/DC.
Audible Alarm: At least 85 dB @ 1' distance (depends on model).
Visual Alarm: Red LED for water level; Yellow LED for low battery (battery powered model only); Green LED for power condition (external powered models only).
Temperature Limits: 32 to 122°F (0 to 50°C).
Power Requirements: Battery powered model: 3V CR2450 lithium metal battery, installed functional, user replaceable; External powered models: 24 VAC (±10%) or 11-27 VDC.
Power Consumption: Battery powered model: 0.9 mA steady state / 3.0 mA during alarm condition; External powered models: 30 mA steady state / 85 mA during alarm condition.
Battery Life: 5 years steady state / 48 hours during alarm condition.
Electrical Connections: 4.9" (1.5 m), 22 AWG, PVC, UL plenum rated cable.
Enclosure Material: ABS and polycarbonate with flammability classification UL 94 V-0.
Enclosure Rating: Audible alarm models: Watertight up to 3/4 of the body height; Non-audible alarm models: NEMA 6P (IP 68) submersible.
Weight: 4.85 oz (137.5 g).
Agency Approvals: CE.

ACCESSORIES

Model	Description
A-WD3-BRK	Replacement mounting bracket

SERIES WD | W.E. ANDERSON™ BY DWYER

WATER DETECTOR AND SENSOR TAPE

Detects Low Levels Of Conductive Liquids, Large Measuring Area

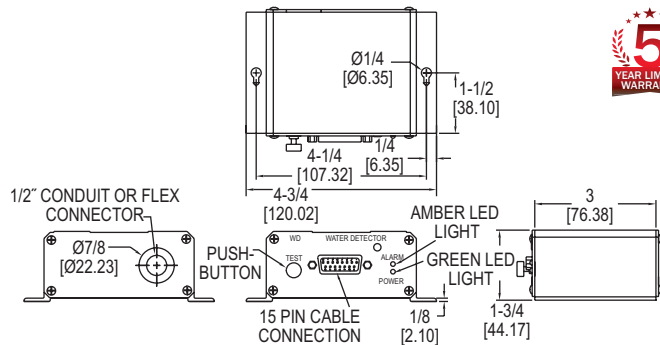

The **Series WD Water Detector and Sensor Tape** is designed for dependable detection of water presence even of low conductive liquids. The water sensing tape attaches to module and if any liquid comes in contact with the tape the resistance is changed and the alarm will be triggered. The sensing tape is 1" wide and can be bought in lengths of 5, 10, 15 and 25" and is powered by 24 VAC or 24-30 VDC.

FEATURES/BENEFITS

- Sturdy and reliable aluminum enclosure
- Hydrophobic tape does not absorb any liquid allowing for faster drying time and faster return to service after water leak
- Multiple tapes can be connected together to extend the coverage area

APPLICATIONS

- Drip pans under HVAC equipment
- Computer rooms
- Telecommunication facilities
- Leak detection around water pumps

SPECIFICATIONS

Service: Conductive liquid.
Switch Type: DPDT.
Electrical Rating: 1 A @ 24 VAC/VDC.
Power Requirements: 24 VAC, 24-30 VDC.
Power Consumption: 35 mA maximum.
Electrical Connections: Screw terminals.
Conduit Connections: Hole for 1/2" conduit.
Enclosure: Extruded aluminum.
Sensor Tape: 1" (25.4 mm) wide and 5', 10', 15' or 25' long.
Weight: 8 oz (.23 kg).

MODEL CHART

Model	Description
WD	Water module
TP05	5' (1.52 m) tape
TP10	10' (3.05 m) tape
TP15	15' (4.57 m) tape
TP25	25' (7.62 m) tape



SERIES CFS2 | MERCROID® BY DWYER

CABLE FLOAT SWITCH

Mercury-Free, UL/CSA Approved Options

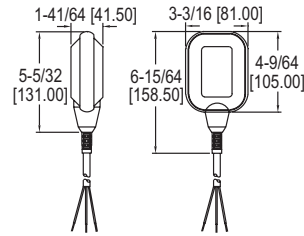

The Series CFS2 Cable Float Switch is a mechanically actuated floating switch intended to activate electrical components, such as pumps, to start and stop automatically. Optional cables are available. Contact factory for cable length options ranging from 10 to 70' (3 to 21 m).

FEATURES/BENEFITS

- High reliability with mercury-free, magnetic, mechanical internal design
- Economical pricing with multiple option available for increased versatility
- Easy installation with counterweights and cable hangers to suit a variety of mounting applications

APPLICATIONS

- Water level monitoring
- Tank level control
- High or low level alarm
- Municipal water control
- Industrial water control
- Filling or draining reservoirs and tanks
- Pump automation

SPECIFICATIONS

Service: Compatible liquids.
Wetted Materials: Enclosure: Polypropylene; Cable: See model chart.
Temperature Limits: 32 to 122°F (0 to 50°C).
Pressure Limits: 14.5 psi (1 bar).
Enclosure Rating: IP68.
Switch Type: See model chart.

Electrical Rating: CFS2-XXBXX-XX: 10 (8) A @ 250 VAC; CFS2-XXDXX-XX: 1 HP @ 125 VAC 16 FLA; 2 HP @ 250 VAC 12 FLA.
Shipping Weight: Enclosure: 5.43 oz (154 g); Cable: 0.77 oz (21.27 g) per ft.
Agency Approvals: See model chart.

ACCESSORIES

Model	Description
A-457	7.76 oz (220 g) counterweight
A-459	Cable hanger

MODEL CHART

Model	Cable Type	Approvals	Switch Type	Cable Length	Model	Cable Type	Approvals	Switch Type	Cable Length
CFS2-ONBPN-20	PVC	CE	SPST NO	20' (6.10 m)	CFS2-DNBPN-40	PVC	CE	SPDT	40' (12.19 m)
CFS2-ONBPN-30	PVC	CE	SPST NO	30' (9.14 m)	CFS2-DNBPN-50	PVC	CE	SPDT	50' (15.24 m)
CFS2-ONBPN-40	PVC	CE	SPST NO	40' (12.19 m)	CFS2-DNBPN-60	PVC	CE	SPDT	60' (18.29 m)
CFS2-ONBPN-50	PVC	CE	SPST NO	50' (15.24 m)	CFS2-DNBPN-80	PVC	CE	SPDT	80' (24.38 m)
CFS2-CNBPN-20	PVC	CE	SPST NC	20' (6.10 m)	CFS2-DNBPN-100	PVC	CE	SPDT	100' (30.48 m)
CFS2-CNBPN-30	PVC	CE	SPST NC	30' (9.14 m)	CFS2-OGDSN-20	SJOW	UL/CSA	SPST NO	20' (6.10 m)
CFS2-CNBPN-40	PVC	CE	SPST NC	40' (12.19 m)	CFS2-OGDSN-30	SJOW	UL/CSA	SPST NO	30' (9.14 m)
CFS2-CNBPN-50	PVC	CE	SPST NC	50' (15.24 m)	CFS2-OGDSN-40	SJOW	UL/CSA	SPST NO	40' (12.19 m)
CFS2-DNBPN-7	PVC	CE	SPDT	7' (2.13 m)	CFS2-OGDSN-50	SJOW	UL/CSA	SPST NO	50' (15.24 m)
CFS2-DNBPN-10	PVC	CE	SPDT	10' (3.05 m)	CFS2-CGDSN-20	SJOW	UL/CSA	SPST NC	20' (6.10 m)
CFS2-DNBPN-15	PVC	CE	SPDT	15' (4.57 m)	CFS2-CGDSN-30	SJOW	UL/CSA	SPST NC	30' (9.14 m)
CFS2-DNBPN-20	PVC	CE	SPDT	20' (6.10 m)	CFS2-CGDSN-40	SJOW	UL/CSA	SPST NC	40' (12.19 m)
CFS2-DNBPN-30	PVC	CE	SPDT	30' (9.14 m)	CFS2-CGDSN-50	SJOW	UL/CSA	SPST NC	50' (15.24 m)

MODEL L8 | W.E. ANDERSON™ BY DWYER

FLOTECT® LIQUID LEVEL SWITCHES

Low Cost, Leak Proof Body, Excellent Chemical Resistance

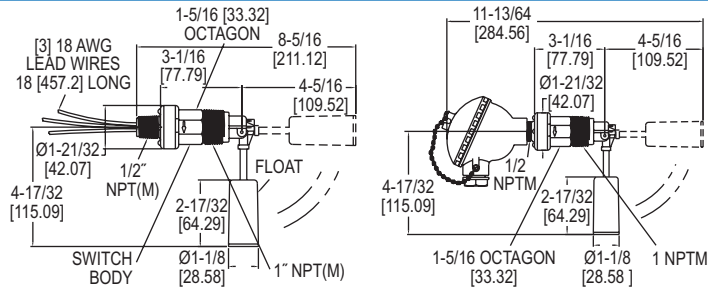

The Model L8 FloTECT® Liquid Level Switches are float switches constructed of polyphenylene sulfide, Ceramic 8 and 316 SS. This liquid level switch provides accurate set point control of liquids with specific gravities as low as 0.6.

FEATURES/BENEFITS

- Features a leak proof body and float constructed from tough, durable polyphenylene sulfide which has excellent chemical resistance
- Liquid level snap switch is magnetically actuated with no direct mechanical linkage to leak or fail, assuring longer life and decreased maintenance costs
- Quick and easy installation with simple placement of the unit in a horizontal position with the index arrow pointing down
- UL recognized as an industrial motor controller per UL standard 508, suitable for mounting in a protected environment

APPLICATIONS

- Environmental control
- Waste water
- Scrubber systems
- Holding tanks
- Cooling towers
- Chemical/petroleum processing
- Plating and washing tanks
- Sewage treatment
- Car washes
- Remediation systems
- Thermal storage systems
- HVAC and building automation systems

SPECIFICATIONS

Service: Compatible liquids.
Wetted Materials: Float and body: Polyphenylene sulfide (PPS); Pin and spring: 316 SS or Inconel®; Magnet: Ceramic 8.
Temperature Limit: 212°F (100°C).
Pressure Limit: 150 psig (10.34 bar).
Enclosure Rating: General purpose. WP/WP2 option is weatherproof.
Switch Type: SPDT snap switch. MV option is a SPDT gold contact snap switch.

Electrical Rating: 5 A @ 125/250 VAC, 5 A resistive, 3 A inductive @ 30 VDC. MV option: 1 A @ 125 VAC, 1 A resistive, 0.5 A inductive @ 30 VDC.
Electrical Connections: 18 AWG, 18" (460 mm) long.
Conduit Connection: 1/2" male NPT, 1/2" female NPT on WP and WP2.
Process Connection: 1" male NPT.
Mounting Orientation: Horizontal with index arrow pointing down.
Weight: 5 oz (0.142 kg).
Specific Gravity: 0.6 minimum.
Agency Approvals: CE, cURus.

OPTIONS

To order add suffix:	Description
-MV	Gold plated contacts for dry circuits. Rated 1 A @ 125 VAC; 1 A resistive, 0.5 A inductive @ 30 VDC
Example: L8-MV	
-INC	Inconel® alloy. Inconel® alloy replaces standard 316 SS wetted parts. Wetted parts are Inconel® Alloy, Ceramic 8, and Polyphenylene Sulfide.
Example: L8-INC	
-WP	Weatherproof enclosure. Optional housing is phenylpolioxide and provides weatherproof protection for electrical wiring. (Not UL approved)
Example: L8-WP	
-WP2	Weatherproof enclosure. Optional housing is aluminum and provides weatherproof protection for electrical wiring. (Not UL approved)
Example: L8-WP2	

Model	Description
L8	Level switch

Inconel® is a registered trademark of Huntington Alloys Corporation

SUBMERSIBLE LEVEL TRANSMITTERS

Perfect for Ground Water and Wells, Lightning Protected, Standard 72 Hour Lead Time



SBLT2



SBLTX



NOW WITH 72 HOUR
OUT OF STOCK LEAD TIME!

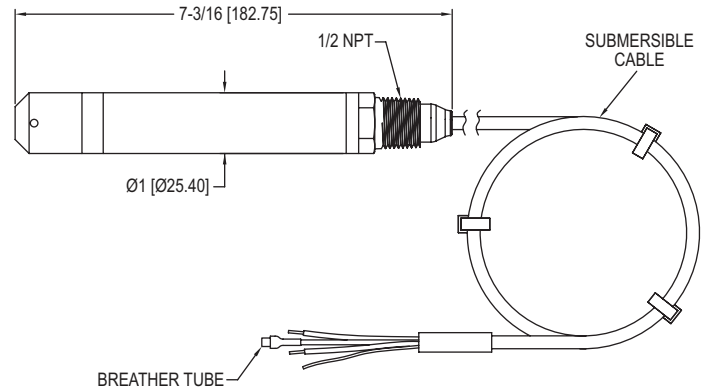

The Series SBLT2 & SBLTX Submersible Level Transmitters are manufactured for years of trouble free service. These series measure the height of liquid above the position in the tank referenced to atmospheric pressure. The transmitter consists of a piezoresistive sensing element, encased in a 316 SS housing.

FEATURES/BENEFITS

- Slim design for tight applications with bullet nose design which protects the diaphragm from damage
- Incorporates lightning and surge protection utilizing dual arrestor technology, grounded to case, eliminating both power supply surges and lightning ground strike transients (surge protection is not guaranteed and is not covered by warranty) on SBLT2 models
- Maintenance free filter eliminates particulate or water droplets from entering the transducer
- UL approved intrinsically safe on SBLTX models for use in hazardous locations when used with proper barrier
- 270 lb tensile strength shielded and vented cable
- Excellent chemical compatibility
- NPT connection allows the unit to be rigidly installed in a pipe/conduit, or the addition of a A-625 hanging loop for attaching a chain for pulling out of the installation
- Standard 72 hour lead time ensures minimal downtime

APPLICATIONS

- Well monitoring
- Ground water monitoring
- Environmental remediation
- Surface water monitoring
- Down hole
- Water tanks

MODEL CHART			
Model	Range psi* (ft w.c.) [m w.c.]	Cable Length ft (m)	Cable Type
SBLT2-5-40-ETFE	5 (11.54) [3.52]	40 (12.2)	ETFE
SBLT2-10-40-ETFE	10 (23.09) [7.04]	40 (12.2)	ETFE
SBLT2-15-60-ETFE	15 (34.63) [10.56]	60 (18.3)	ETFE
SBLT2-20-60-ETFE	20 (46.18) [14.08]	60 (18.3)	ETFE
SBLT2-5-40	5 (11.54) [3.52]	40 (12.2)	Polyurethane
SBLT2-10-40	10 (23.09) [7.04]	40 (12.2)	Polyurethane
SBLT2-15-60	15 (34.63) [10.56]	60 (18.3)	Polyurethane
SBLT2-20-60	20 (46.18) [14.08]	60 (18.3)	Polyurethane
SBLT2-3.5M-5M	4.97 (11.48) [3.5]	16.40 (5)	Polyurethane
SBLT2-5M-10M	14.21 (32.81) [10]	32.81 (10)	Polyurethane
SBLT2-10M-18M	25.58 (59.06) [18]	59.06 (18)	Polyurethane

*Configured ranges below 5 psi (11.54' w.c.) (3.52 m w.c.) ±1% FS accuracy

Note: For intrinsically safe approval, change model number from SBLT2 to SBLTX. For custom ranges or cable lengths, contact factory.

SPECIFICATIONS

Service: Compatible liquids.
Wetted Materials: Body: 316 SS, 316L SS; Bullet nose: PVC; Cable: Polyether polyurethane or ETFE; Seals: Fluoroelastomer.
Accuracy: ±0.25% FS.
Temperature Limit: SBLT2: Polyurethane: 0 to 150°F (-18 to 66°C); ETFE: 0 to 200°F (-18 to 93°C); SBLTX -4 to 176°F (-20 to 80°C); Polyurethane: -4 to 149°F (-20 to 65°C).
Compensated Temperature Range: SBLT2: 0 to 140°F (-18 to 60°C); SBLTX: 0 to 176°F (-18 to 80°C).
Thermal Effect: ±0.02% FS/°F.
Pressure Limit: 2X FS.
Power Requirement: SBLT2: 10-30 VDC (≤ 1000 ft (305 m) of cable); SBLTX: 10-28 VDC.
Output Signal: 4-20 mA DC, 2-wire.
Response Time: 50 ms.
Max. Loop Resistance: 900 Ω at 30 VDC.
Electrical Connections: Wire pigtail.
Mounting Orientation: Suspended in tank below level being measured.
Electrical Protection: SBLT2: Lightning and surge protection; SBLTX: None.
Weight: 2.2 lb (1.0 kg).
Agency Approvals: SBLT2: CE; SBLTX: CE, cULus intrinsically safe for Class I, Div. 1, Groups A, B, C, D; Class II, Div. 1, Groups E, F, G; Class III Div. 1. (according to control drawing 001833-43)*.
 *Up to 196' (59.5 m) for ETFE cable; Up to 333' (101.5 m) for polyurethane cable

OPTIONS

Model	Description
-P1	1/4" NPT male
-P2	1/4" NPT female
-P3	1/4" BSPT male ISO 228 R
-P4	1/4" BSPT female ISO 228 RC
-P11	3/4" clean-out type



-P11 option

ACCESSORIES

Model	Description
MTL5541	Galvanic barrier
MTL7706	Intrinsically safe zener barrier
A-297	Dessicant filter for vent tube. Removes humidity for protection of the sensor. Changes color to show saturation
A-625	316 SS cable hanger use with NPT option for attaching chain for easy pulling out of application



A-297

A-625

SUBMERSIBLE LEVEL TRANSMITTERS

Perfect for Sludge and Slurries, Lightning Protected, Standard 72 Hour Lead Time



PBLT2

PBLTX

NOW WITH 72 HOUR
OUT OF STOCK LEAD TIME!

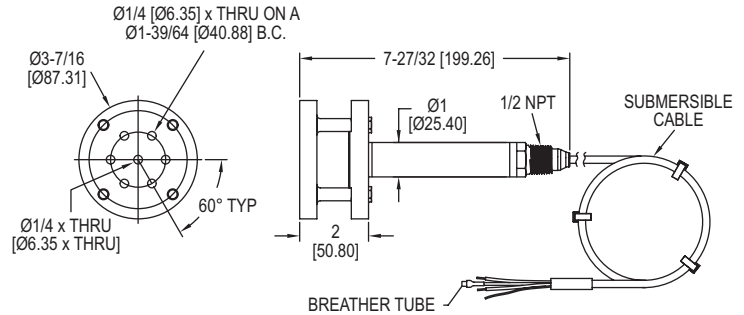

The Series PBLT2 & PBLTX Submersible Level Transmitters are manufactured for years of trouble free service in the harshest applications. These Series measure the height of liquid above the position in the tank referenced to atmospheric pressure. The transmitter consists of a piezoresistive sensing element, encased in a 316 SS housing with cage and large diameter 316 SS diaphragm seal.

FEATURES/BENEFITS

- Durable cage design with large diameter 316 SS diaphragm seal that is non-clogging and damage resistant to floating solids
- Incorporates lightning and surge protection utilizing dual arrestor technology, grounded to case, eliminating both power supply surges and lightning ground strike transients (surge protection is not guaranteed and is not covered by warranty) on PBLT2 models
- Maintenance free filter eliminates particulate or water droplets from entering the transducer
- UL approved intrinsically safe on PBLTX models for use in hazardous locations when used with proper barrier
- 270 lb tensile strength shielded and vented cable
- Excellent chemical compatibility
- NPT connection allows the unit to be rigidly installed in a pipe/conduit, or the addition of a A-625 hanging loop for attaching a chain for pulling out of the installation
- Standard 72 hour lead time ensures minimal downtime

APPLICATIONS

- Wastewater
- Sludge pits, clarifiers, digesters
- Alum tanks
- Chemical storage tanks
- Oil tanks
- Lime slurry
- Sumps
- Reservoirs

SPECIFICATIONS	
Service:	Compatible liquids.
Wetted Materials:	Body: 316 SS, 316L SS; Cable: Polyether polyurethane or ETFE; Seals: Fluoroelastomer.
Accuracy:	±0.25% FS (includes linearity, hysteresis, and repeatability).
Temperature Limit:	PBLT2: 0 to 200°F (-18 to 93°C); PBLTX: ETFE -4 to 176°F (-20 to 80°C); Polyurethane: -4 to 149°F (-20 to 65°C).
Compensated Temperature Range:	PBLT2: 0 to 180°F (-18 to 82°C); PBLTX: 0 to 176°F (-18 to 80°C).
Thermal Effect:	±0.02% FS/°F.
Pressure Limit:	2X FS.
Power Requirement:	PBLT2: 13-30 VDC; PBLTX: 10-28 VDC.
Output Signal:	4-20 mA DC, two wire.
Response Time:	50 ms.
Loop Resistance:	900 Ω.
Electrical Connection:	Wire pigtail.
Mounting Orientation:	Suspended in tank below level being measured.
Electrical Protection:	PBLT2: Lightning and surge protection, PBLTX: none.
Weight:	4.3 lb (2.0 kg).
Agency Approvals:	PBLT2: CE, PBLTX: CE, cULus intrinsically safe for Class I, Div. 1, Groups A, B, C, D; Class II, Div. 1, Groups E, F, G; Class III, Div. 1. (According to control drawing 001833-44)*.
*Up to 196' (59.5 m) for ETFE cable; Up to 333' (101.5 m) for polyurethane cable	

MODEL CHART			
Model	Range psi* (ft w.c.) [m w.c.]	Cable Length ft (m)	Cable Type
PBLT2-5-40	5 (11.54) [3.52]	40 (12.2)	ETFE
PBLT2-10-40	10 (23.09) [7.04]	40 (12.2)	ETFE
PBLT2-15-60	15 (34.63) [10.56]	60 (18.3)	ETFE
PBLT2-20-60	20 (46.18) [14.08]	60 (18.3)	ETFE
PBLT2-5-40-PU	5 (11.54) [3.52]	40 (12.2)	Polyurethane
PBLT2-10-40-PU	10 (23.09) [7.04]	40 (12.2)	Polyurethane
PBLT2-15-60-PU	15 (34.63) [10.56]	60 (18.3)	Polyurethane
PBLT2-20-60-PU	20 (46.18) [14.08]	60 (18.3)	Polyurethane
PBLT2-3.5M-5M-PU	4.97 (11.48) [3.5]	16.40 (5)	Polyurethane
PBLT2-5M-10M-PU	7.10 (16.38) [5]	32.81 (10)	Polyurethane
PBLT2-10M-18M-PU	14.21 (32.78) [10]	59.06 (18)	Polyurethane

*Configured ranges below 5 psi (11.54' w.c.) (3.52 m w.c.) ±1% FS accuracy

Note: For intrinsically safe approval, change model number from PBLT2 to PBLTX. For custom ranges or cable lengths, contact factory.

ACCESSORIES	
Model	Description
MTL5541	Galvanic barrier
MTL7706	Intrinsically safe zener barrier
A-297	Dessicant filter for vent tube. Removes humidity for protection of the sensor. Changes color to show saturation
A-625	316 SS cable hanger use with NPT option for attaching chain for easy pulling out of application



ULTRASONIC LEVEL TRANSMITTER

Explosion-Proof, Mapping Software, 3" (76.2 mm) Measuring Column

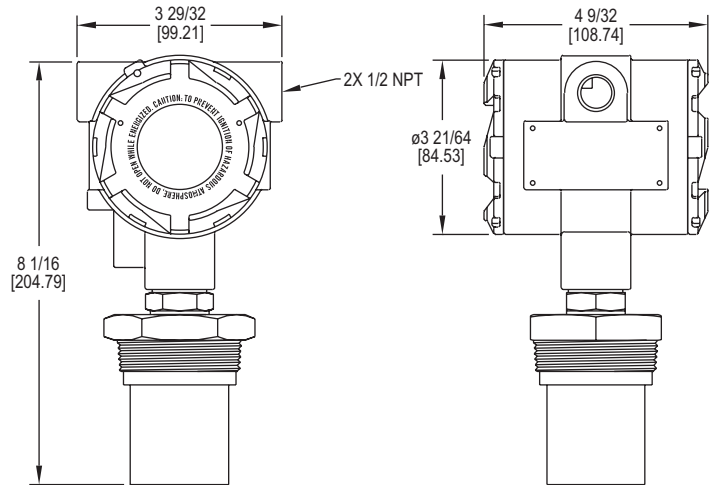

The Series ULT Ultrasonic Level Transmitter provides non-contact measurement of liquid levels in an explosion-proof body. It is capable of measuring up to 32.8' (10 m) with a PVDF sensor and 4-20 mA output.

FEATURES/BENEFITS

- Provides reliable, accurate, and non-contact level measurement of compatible liquids
- Non-contact technology offers no moving parts to wear, jam, corrode, or get coated like contact technologies
- Mapping software makes effective measuring surface only a 3" (76.2 mm) diameter column with no concerns of ladders, pipes, or other tank intrusions in the remaining sound cone
- FM approved explosion-proof making it ideal for use in hazardous locations
- Easy programming with 6 digit LCD display and simple menu structure
- Output range is adjustable with choices of inputting tank dimensions or by filling and emptying the tank while calibrating and it automatically and scaling to levels it senses
- Window cover allows easy viewing of display
- Fail-safe output options and diagnostic capabilities

APPLICATIONS

- Water and wastewater
- Pulp and paper processing
- Chemical processing
- Food and beverage

MODEL CHART	
Model	Range
ULT-11	24.6' (7.5 m)
ULT-21	32.8' (10 m)

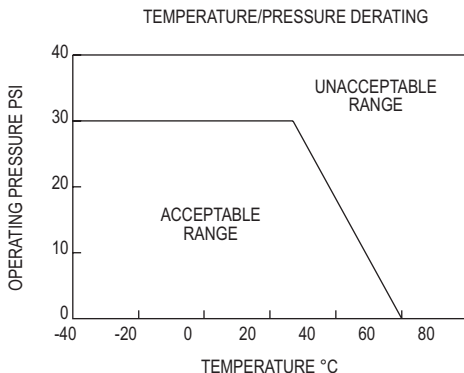

SPECIFICATIONS

Service: Compatible fluids. Not for use with powder and bulk solids.
Wetted Materials: Sensor: PVDF; Process connection: 303 SS; O-ring: Fluoroelastomer.
Ranges: 24.6' (7.5 m), 32.8' (10 m).
Accuracy: ±0.2% FS.
Resolution: 0.079" (2 mm).
Blind Zone: Under 8" (20 cm).
Beam Width: 3" (7.6 cm) diameter.
Temperature Limits: Ambient: -40 to 140°F (-40 to 60°C); Process: -4 to 140°F (-20 to 60°C).
Temperature Compensation: -40 to 140°F (-40 to 60°C).
Pressure Limits: 30 psi (2 bar) up to 25°C (77°F). Above 25°C (77°F), rating decreases 1.667 psi per 1°C increase. See chart.
Power Requirement: 18-28 VDC (two-wire).
Output Signal: 4-20 mA or 20-4 mA (two-wire).
Max. Loop Resistance: 250 Ω at 24 VDC.
Electrical Connections: Screw terminal.
Conduit Connection: 1/2" NPT female (two) or optional M20.
Process Connection: 2" NPT male or optional BSPT.
Enclosure Rating: Weather-proof meets NEMA 4X (IP66), explosion-proof rated Class I, Div. 1, Groups B, C, D; Class II/III, Div. 1, Groups E, F, G.
Mounting Orientation: Vertical.
Failsafe: On lost echo after 30 seconds, user selectable to 4, 20, 21, 22 mA or last signal.
Memory: Non-volatile.
Display: 6 character LCD.
Units: In, cm, ft, m, percent.
Programming: 4 button.
Weight: 4.0 lb (1.8 kg).
Agency Approvals: CE, FM.

ULTRASONIC LEVEL SENSORS

Non-Contact Transmitter, SPST Programmable Relays

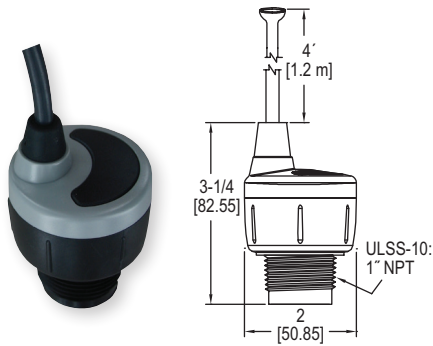

ULSS

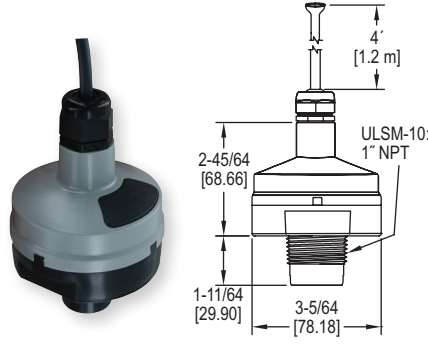

ULSM

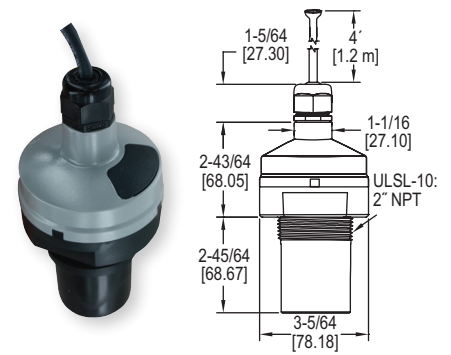

ULSL



The **Series ULSS Ultrasonic Level Sensor** provides non-contact, continuous ultrasonic level measurement of fluids for short range applications. It has a 4.1' (1.2 m) measuring range with a 0.125" (3 mm) accuracy.

The **Series ULSM Ultrasonic Level Sensor** provides non-contact, continuous ultrasonic level measurement of fluids for medium range applications. It has a 9.8' (3 m) measuring range with a ±0.2% of range accuracy.

The **Series ULSL Ultrasonic Level Sensor** provides non-contact, continuous ultrasonic level measurement of fluids for tall range applications. It has a 18' (5.5 m) measuring range with a ±0.2% of range accuracy.

FEATURES/BENEFITS

- Via free software, units can be programmed to transmit an output signal and operate four relays for control applications
- Provides reliable, accurate, and non-contact level measurement of compatible liquids
- Non-contact technology offers no moving parts to wear, jam, corrode, or get coated like contact technologies
- Mapping software makes effective measuring surface only a 3" (76.2 mm) diameter column with no concerns of ladders, pipes, or other tank intrusions in the remaining sound cone
- Ultrasonic technology paired with automatic temperature compensation provides accurate and reliable measurements in almost all conditions
- Fail-safe logic is easily configured to custom applications via free software removing the need for target calibration
- Full NEMA 6P submersible enclosure rating to ensure excellent product durability

APPLICATIONS

- Water and wastewater
- Pulp and paper processing
- Sump and process tanks
- Chemical processing
- Food and beverage

SPECIFICATIONS

Service: Compatible fluids.
Wetted Materials: Sensor: PVDF; O-ring: FKM.
Ranges: See chart.
Accuracy: ULSS: 0.125" (3 mm); ULSM & ULSL: ±0.2% of range.
Resolution: ULSS: 0.019" (0.5 mm); ULSM: 0.039" (1 mm); ULSL: 0.079" (2 mm).
Blind Zone: ULSS: 2" (5 cm); ULSM: 4" (10 cm); ULSL: 8" (20 cm).
Beam Width: ULSS & ULSM: 2" (5 cm); ULSL: 3" (7.62 cm).
Temperature Limits: Process: 20 to 140°F (-7 to 60°C); Ambient: -31 to 140°F (-35 to 60°C).
Temperature Compensation: Automatic.
Pressure Limit: 30 psi (2 bar).
Power Requirement: 12 to 28 VDC.
Output Signal: 4-20 mA, 2-wire; Invert: 4-20 mA or 20-4 mA; Fail-safe: 4 mA, 20 mA, 21 mA, 22 mA, or hold last.
Loop Resistance: 400 Ω max.
Electrical Connections: 4' (1.2 m) 9 conductor shielded cable.
Contact Type: 4 SPST relays.
Contact Rating: 1 A max @ 28 VDC max.
Deadband: Selectable (no hysteresis, 1/4", 1/2", 1", 1/2 cm, 1 cm, 2 cm, 5 cm or not available).
Process Connection: 1" NPT, 1" BSPP (optional).
Enclosure Rating: NEMA 6P (IP68).
Enclosure Material: Polycarbonate; Gland: TPE.
Mounting Orientation: Vertical.
Memory: Non-volatile.
Failsafe: Contact: Power loss: Holds last contact; Power on: Open, close, or last contact.
Programming: Free PC software download (USB adapter required).
Weight: 1 lb (0.45 kg).
Agency Approvals: CE.

ACCESSORIES

Model	Description
ULS-ACC-USB	USB adapter for calibration, PVC
ULS-ACC-121	2" x 1" NPT reducer bushing fitting (sch. 40), PVC
ULS-ACC-122	2" x 1" NPT reducer bushing fitting (sch. 80), PVC
ULS-ACC-131	3" x 2" NPT reducer bushing fitting (sch. 40), PVC
ULS-ACC-132	3" x 2" NPT reducer bushing fitting (sch. 80), PVC
ULS-ACC-142	4" x 2" NPT reducer bushing fitting (sch. 80), PVC
ULS-ACC-221	2" socket x 1" NPT reducer bushing fitting (sch. 40), PVC
ULS-ACC-222	2" socket x 1" NPT reducer bushing fitting (sch. 80), PVC
ULS-ACC-231	3" socket x 2" NPT reducer bushing fitting (sch. 40), PVC
ULS-ACC-232	3" socket x 2" NPT reducer bushing fitting (sch. 80), PVC
ULS-ACC-241	4" socket x 2" NPT reducer bushing fitting (sch. 40), PVC
ULS-ACC-242	4" socket x 2" NPT reducer bushing fitting (sch. 80), PVC
ULS-ACC-510	1" NPT polypropylene side mount bracket
ULS-ACC-520	2" NPT polypropylene side mount bracket

MODEL CHART	
Model	Range
ULSS-10	4.1' (1.25 m)
ULSM-10	9.8' (3 m)
ULSL-10	18' (5.5 m)

Note: USB adapter necessary for calibration. One adapter can program multiple units.

MINIATURE CURRENT SWITCHES

Low Cost, Solid or No Core, LED Confirmation, Adjustable Set Point

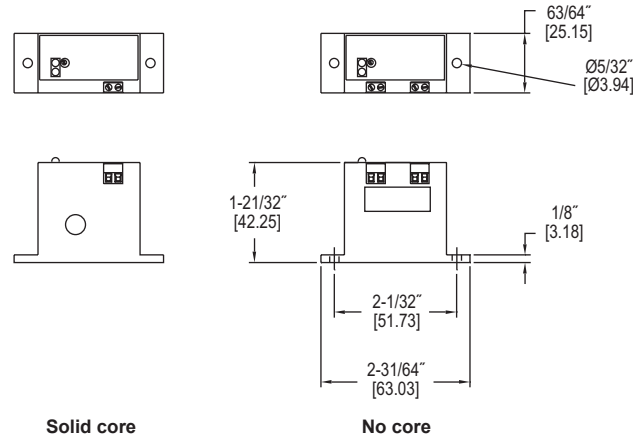
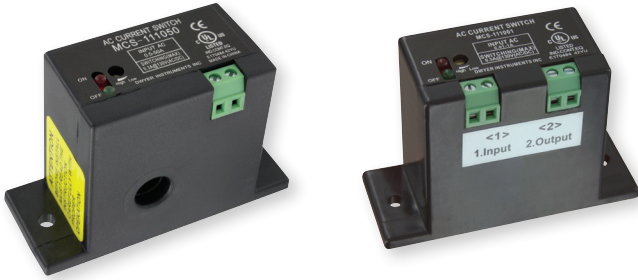

The Series MCS Miniature Current Switches are ideal for monitoring the current usage in fuse boxes and small control panels. Both models have adjustable set points and LED indication to show there is power to the unit and when the switch activates. Set points can be adjusted using the potentiometer next to the LED's. Due to the size of the switch, it is only offered in solid core and no core versions. The no core version has terminal blocks which can accept currents up to 1 A directly into the unit.

FEATURES/BENEFITS

- Integral mounting flange for quick installation
- Compact size fits in any space

APPLICATIONS

- BAS
- HVAC

SPECIFICATIONS

Amperage Range: MCS-111050: 0.5 to 50 A AC continuous; MCS-111001: 0.01 to 1 A AC continuous.
Output Rating: Isolated, N.O. 0.3 A @ 130 V DC/AC.
Power Requirements: None, self-powered.
Hysteresis: 1%.
Response Time: <200 ms.
Temperature Limits: 32 to 122°F (0 to 50°C).
Humidity Limits: 10 to 95% RH (non-condensing).
Enclosure Rating: UL 94 V-0 flammability rated ABS, insulation class 600 V.
Weight: 0.5 oz (14.5 g).
Agency Approvals: CE, cULus.

MODEL CHART				
Model	Case	Set Point	Minimum Set Point	LED
MCS-111050	Solid core	Adjustable	0.50	Red/geen
MCS-111001	No core (terminal connection)	Adjustable	0.01	Red/green

SERIES CCS

CURRENT SWITCHES

Solid or Split Core, LED Visual Confirmation, Fixed or Adjustable Set Point

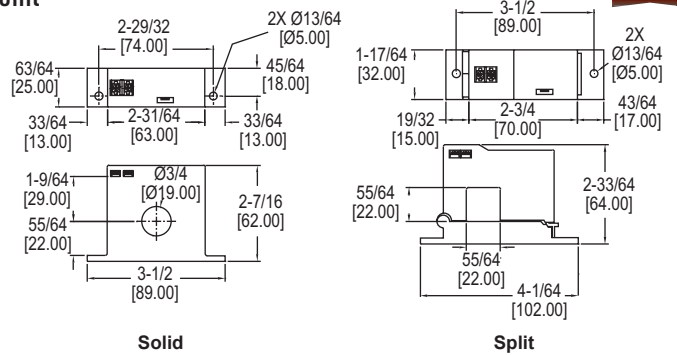

The Series CCS Current Switches are ideal for monitoring the operating status of fans, pumps, and motors. These self-powered switches can be hung or tied directly to cables or wires. For use on existing installations, split core models can be installed without disconnecting cables. LED indicators provide a visual confirmation that the current is flowing through the core. Both fixed and adjustable set points are available. The adjustable models utilize a potentiometer to easily adjust the set point.

FEATURES/BENEFITS

- Integral mounting flange for quick installation
- Solid core or split core configurations
- LED Indicator

APPLICATIONS

- BAS
- HVAC

SPECIFICATIONS

Amperage Range: 0 to 200 A AC.
Maximum Switch Rating: For dry contact models: 0.3 A @ 135 VAC/DC; For non-dry contact models: 1 A @ 240 VAC.
Power Requirements: None, self-powered.
Temperature Limits: -22 to 158°F (-30 to 70°C).
Humidity Limits: 0 to 95% (non-condensing).
Isolation Voltage: 2000 V.
Frequency: 40 to 400 Hz.
Enclosure Rating: UL 94 V-0 flammability rated, ABS plastic housing.
Agency Approvals: CE, cULus.

MODEL CHART					
Model	Case	Set Point	Minimum Set Point (A)	LED	Dry Contact Output
CCS-121050	Solid core	Fixed	0.50 (±0.2)	Red	Yes
CCS-111100	Solid core	Adjustable	1.00 (±0.2)	Red/green	No
CCS-221100	Split core	Fixed	1.00 (±0.2)	Red	Yes
CCS-211150	Split core	Adjustable	1.50 (±0.2)	Red/green	No
CCS-131100	Solid core	Adjustable	1.00 (±0.2)	Red/green	Yes
CCS-231150	Split core	Adjustable	1.50 (±0.2)	Red/green	Yes

MINIATURE CURRENT SWITCHES

Split Core, Integral Mounting Tabs

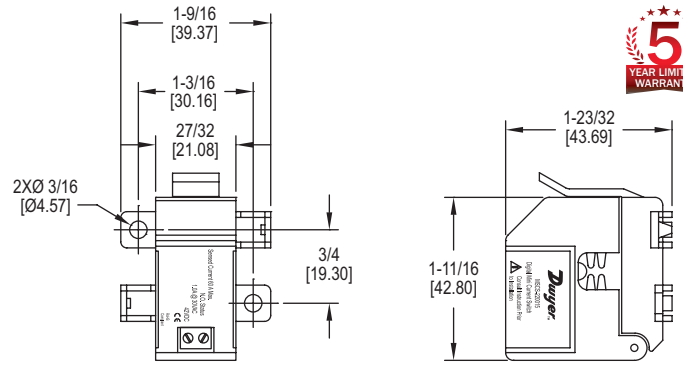

The **Model MSCS Miniature Current Switches** are low cost solutions for monitoring on and off status of light to medium current loads in compact spaces. This unit has a split core design and has a fixed set point of 0.15 amps. It is designed to detect changes in operating current to prevent motor belt loss, slippage, or mechanical failure.

FEATURES/BENEFITS

- Integral mounting flange for quick installation
- Compact size fits in any space

APPLICATIONS

- BAS
- HVAC
- Small industrial motors

MODEL CHART	
Model	Motor Application
MSCS-220015	Miniature split core current switch

SPECIFICATIONS	
Amperage Range:	0.15 to 60 A.
Output:	NO.
Power Requirements:	None, self-powered.
Temperature Limits:	5 to 140°F (-15 to 60°C).
Humidity Limits:	0 to 95%, non-condensing.
Isolation Voltage:	300 VAC RMS.
Frequency:	50/60 Hz.
Enclosure Rating:	UL 94 V-0 flammability rated, ABS plastic housing.
Agency Approvals:	CE, cULus.

SERIES SSCS

SURE-SET CURRENT SWITCHES

Split Core, Adjustable Set Point

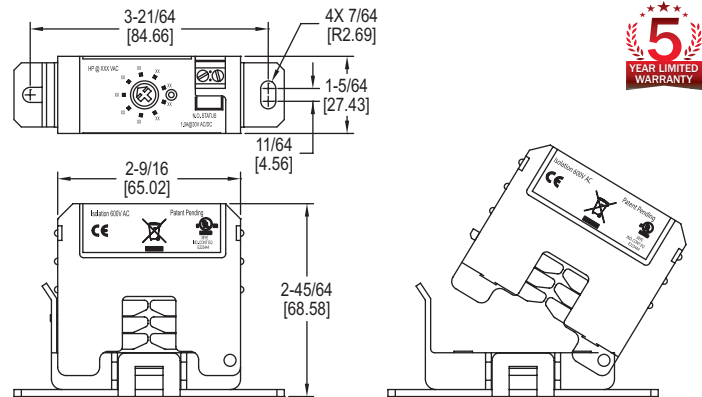

The **Series SSCS Sure-Set Current Switches** provide a unique approach to calibration and installing current sensors in a low cost, fast, and accurate design. Selecting the set point has never been easier, with each model having 9 pre-configured adjustable HP set points. This feature eliminates the need to work within a live enclosure, reducing the risk of arc flash on installation.

FEATURES/BENEFITS

- Models for 230 VAC or 480 VAC applications
- Low and high motor HP ranges available
- 9 pre-set HP set points for faster installation

APPLICATIONS

- BAS
- HVAC
- Industrial motors

MODEL CHART			
Model	Case	Motor HP Range	Motor Application
SSCS-211100-230	Split	1, 2, 3, 5, 7.5, 10, 15, 20, 25	230 VAC
SSCS-211200-480	Split	2, 3, 5, 7.5, 10, 15, 20, 25, 30	480 VAC
SSCS-211500-230	Split	5, 7.5, 10, 15, 20, 25, 30, 40, 50	230 VAC
SSCS-211150-480	Split	15, 20, 25, 30, 40, 50, 60, 75, 100	480 VAC

SPECIFICATIONS	
Output:	Isolated, NO.
Power Requirements:	None, self-powered.
Temperature Limits:	5 to 140°F (-15 to 60°C).
Humidity Limits:	0 to 95%, non-condensing.
Isolation Voltage:	600 VAC RMS.
Frequency:	50/60 Hz.
Enclosure Rating:	UL 94 V-0 flammability rated, ABS plastic housing.
Agency Approvals:	CE, cULus.

ACCESSORIES	
Model	Description
SCT-RLY-12	12 VAC trigger voltage relay module
SCT-RLY-24	24 VAC trigger voltage relay module

CURRENT SWITCHES

Optional Relay Output, Solid or Split Core Case

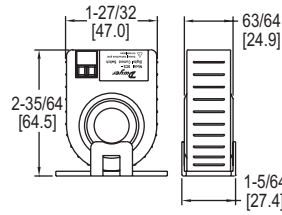

SCS-111100 and SCS-120025

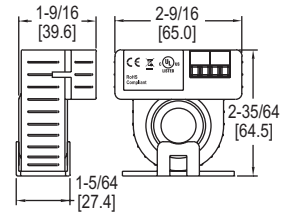

SCS-111100-R

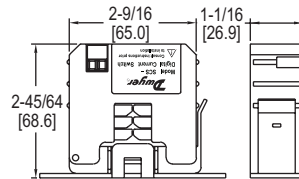

SCS-220015, SCS-220150, and SCS-211125

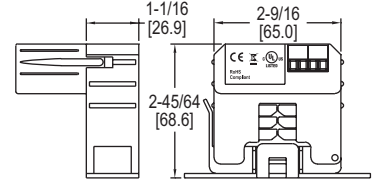

SCS-220150-R and SCS-211125-R

The Series SCS Current Switches are ideal for monitoring whether fans, pumps, or motors are operating. The current flowing through the core of the device powers the circuit without an external power supply. All models have a built in solid state output and are easy to install. Optional LED's and 10 Amp relay modules are available. The Series SCS is available in both split and solid core configurations.

FEATURES/BENEFITS

- Integral mounting flange for quick installation
- Solid core or split core configurations

APPLICATIONS

- BAS
- HVAC

SPECIFICATIONS

Output: Isolated, 1 A @ 30 VAC/DC max, NO.
External Relay: SPST N.O., 10 A at 260 VAC (5 A at 30 VDC).
Power Requirements: None, self-powered.
Temperature Limits: 5 to 140°F (-15 to 60°C).
Isolation Voltage: 600 VAC RMS.
Frequency: 50/60 Hz.
Enclosure Rating: UL, 94 V-0 flammability rated, ABS plastic housing.
Agency Approvals: CE, cULus.

MODEL CHART					
Model	Case	Amperage Range	Set Point	Switch Mode	Snap-on Relay
SCS-120025	Solid	.25 to 200 A	0.25 fixed	Under	No
SCS-111100	Solid	1 to 135 A	Adjustable	Over/under	No
SCS-111100-R	Solid	1 to 135 A	Adjustable	Over/under	Yes
SCS-220015	Split	.15 to 200 A	0.15 fixed	Under	No
SCS-220150	Split	1.5 to 200 A	1.5 fixed	Under	No
SCS-211125	Split	1.25 to 135 A	Adjustable	Over/under	No
SCS-220150-R	Split	1.5 to 200 A	1.5 fixed	Under	Yes
SCS-211125-R	Split	1.25 to 135 A	Adjustable	Over/under	Yes

CURRENT TRANSFORMERS

Solid or Split Core, Field Selectable Range

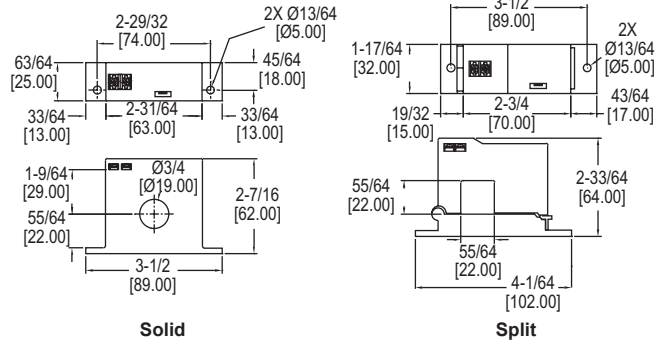

The Series CCT40/50 Current Transformers are a low cost alternative for measuring power and monitoring the operation of fans, pumps, or other equipment. For use on existing installations, split core models can be installed without disconnecting cables. Each model offers three jumper selectable ranges and a choice of three different outputs.

FEATURES/BENEFITS

- Integral mounting flange for quick installation
- Solid core or split core configurations
- Jumper selectable range

APPLICATIONS

- BAS
- HVAC

MODEL CHART				
Model	Range	Output	Power Requirements	Case
CCT40-202	10/20/50 A	0-5 V	Self-powered	Solid core
CCT50-202	100/150/200 A	0-5 V	Self-powered	Solid core
CCT40-102	10/20/50 A	0-5 V	Self-powered	Split core
CCT50-102	100/150/200 A	0-5 V	Self-powered	Split core
CCT40-203	10/20/50 A	0-10 V	Self-powered	Solid core
CCT50-203	100/150/200 A	0-10 V	Self-powered	Solid core
CCT40-200	10/20/50 A	4-20 mA	15 to 42 VDC, loop powered	Solid core
CCT50-200	100/150/200 A	4-20 mA	15 to 42 VDC, loop powered	Solid core
CCT40-100	10/20/50 A	4-20 mA	15 to 42 VDC, loop powered	Split core
CCT50-100	100/150/200 A	4-20 mA	15 to 42 VDC, loop powered	Split core

SPECIFICATIONS

Amperage Range: Field selectable; up to 200 A (depending on model).
Output: 0-5 V, 0-10 V, or 4-20 mA (depending on model).
Power Requirements: Self-powered or 15-42 VDC loop powered (depending on model).
Accuracy: 1%.
Temperature Limits: -22 to 158°F (-30 to 70°C).
Humidity Limits: 0 to 95% (non-condensing).
Response Time: 250 ms to 90%.
Isolation Voltage: 2000 V.
Frequency: 10 to 400 Hz.
Enclosure Rating: UL 94 V-0 flammability rated, ABS plastic housing.
Agency Approvals: CE, cULus.

TRUE RMS CURRENT TRANSFORMERS

Solid or Split Core, Field Selectable Range

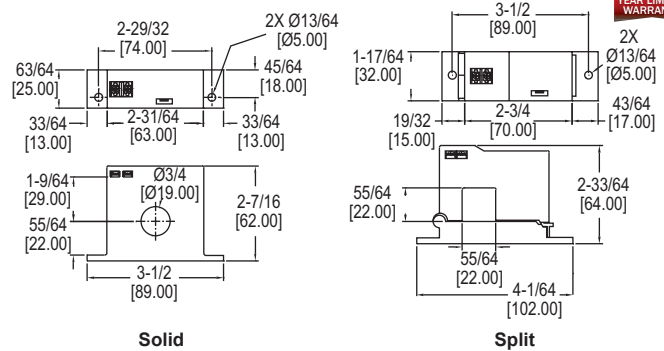

The Series CCT60/70 True RMS Current Transformers are a low cost alternative for providing true RMS outputs on distorted AC waveforms. True RMS outputs are ideal for nonlinear loads or noisy circuits. For existing installations, split core models can be installed without disconnecting cables. Each model offers three jumper selectable ranges to reduce the risk of ordering the wrong model.

FEATURES/BENEFITS

- Integral mounting flange for quick installation
- Solid core or split core configurations
- Jumper selectable range
- True RMS

APPLICATIONS

- BAS
- HVAC

MODEL CHART		
Model	Range	Case
CCT60-200	10/20/50 A	Solid core
CCT70-200	100/150/200 A	Solid core
CCT60-100	10/20/50 A	Split core
CCT70-100	100/150/200 A	Split core

SPECIFICATIONS

Amperage Range: Up to 200 A (depending on model).
Output: 4-20 mA, true RMS.
Power Requirements: 24 VDC nominal.
Accuracy: 1%.
Temperature Limits: -22 to 158°F (-30 to 70°C).
Humidity Limits: 0 to 95% (non-condensing).
Response Time: 250 ms to 90%.
Isolation Voltage: 2000 V.
Frequency: 10 to 400 Hz.
Enclosure Rating: UL 94 V-0 flammability rated, ABS plastic housing.
Agency Approvals: CE, cULus.



MODEL BPS-005

LOW COST DC POWER SUPPLY

Regulated 0.5 A, 1 A Fuse Protection

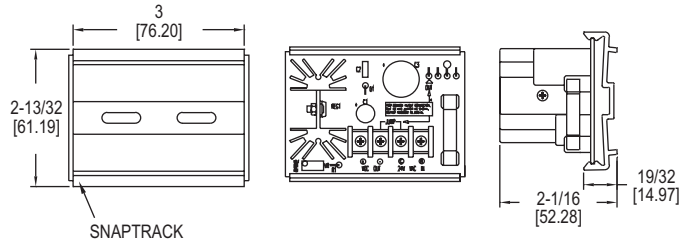

The **Model BPS-005 Low Cost DC Power Supply** is a regulated .5 A power supply that accepts 24 VAC input and provides an adjustable 1.5-29 VDC output. Output voltage adjustments are made using the on-board potentiometer while measuring the output with a multimeter. A compact snap track design allows the power supply to be surface mounted within a panel.

FEATURES/BENEFITS

- Snap track design allowing for easy panel installation
- Regulated 0.5 Amp

APPLICATIONS

- BAS
- HVAC

SPECIFICATIONS	
Input: 24 VAC/VDC 50/60 Hz.	Humidity Limits: 95% (non-condensing).
Output: 24 VDC (full wave rectified and regulated) adjustable 1.5-29 VDC, 0.5 A max.	Weight: 0.4 lb.
Maximum Current Output: 0.5 A.	Agency Approvals: Meets the technical requirements of EU Directive 2011/65/ EU (RoHS II).
Over-Current Protection: 1 A fuse.	
Operating Temperature: 32 to 130°F (0 to 55°C).	

MODEL CHART	
Model	Description
BPS-005	Low cost DC power supply

MODEL BPS-015

LOW COST DC POWER SUPPLY

Regulated 1.5 A, 3 A Fuse Protection

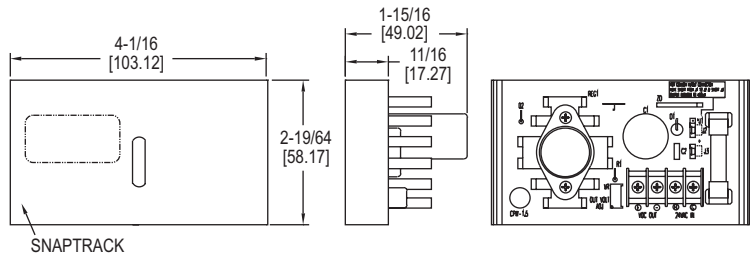
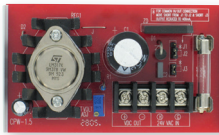

The **Model BPS-015 Low Cost DS Power Supply** is used to convert 24 VAC to a regulated DC power source for transmitters with 4-20 mA outputs. The output voltage can be field adjusted from 1.5-27 V using a potentiometer. The 3 A fuse protects the power supply from over-current conditions. The snap-on bracket can be quickly surface mounted to any flat surface.

FEATURES/BENEFITS

- Snap track design allowing for easy panel installation
- Regulated 1.5 Amp

APPLICATIONS

- BAS
- HVAC

SPECIFICATIONS	
Input: 24 VAC/VDC 50/60 Hz.	Temperature Limits: 32 to 130°F (0 to 55°C).
Output: 24 VDC (full wave rectified and regulated) adjustable 1.5-27 VDC.	Humidity Limits: 95% (non-condensing).
Maximum Current Output: 1.5 A (de-rated to 400 mA for non-isolated circuits).	Weight: 0.4 lb.

MODEL CHART	
Model	Description
BPS-015	Power supply

SERIES A-700

POWER SUPPLY

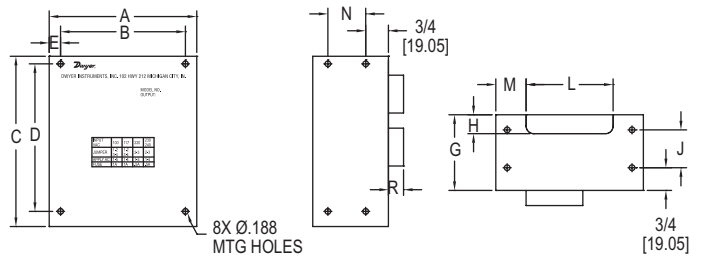

Dim.	0.5 amp	2.4 amp	4.8 amp	Dim.	0.5 amp	2.4 amp	4.8 amp	Dim.	0.5 amp	2.4 amp	4.8 amp
A	4 [101.6]	4-7/8 [123.83]	9 [228.6]	E	25/64 [9.92]	1/4 [6.35]	1/2 [12.7]	L	17/64 [14.68]	2-55/64 [72.63]	-
B	3-3/8 [85.73]	4-1/8 [104.78]	8 [203.2]	G	1-5/8 [41.28]	2-1/2 [63.5]	2-3/4 [69.85]	M	51/64 [20.24]	1-1/32 [26.19]	-
C	4-7/8 [123.84]	5-5/8 [142.88]	4-7/8 [123.83]	H	37/64 [14.68]	43/64 [17.07]	-	N	-	1-1/4 [31.75]	1-1/4 [31.75]
D	4-1/8 [104.78]	4-7/8 [123.83]	4-1/8 [104.78]	J	-	1-1/4 [31.75]	1-1/4 [31.75]	R	29/64 [11.51]	29/64 [11.51]	17/32 [13.49]

The economical and reliable **Series A-700 Power Supply** is suitable for powering all Dwyer pressure, temperature or air velocity transmitters. Inexpensive, open-frame design allows convenient access to input/output solder terminals. Auxiliary inputs are selectable for operation from power sources found worldwide. Compact size eases enclosure installations.

FEATURES/BENEFITS

- Universal supply voltage input
- Compact size

APPLICATIONS

- BAS
- HVAC

MODEL CHART	
Model	Description
A-700	0.5 A
A-700-2	2 A
A-700-4	4.8 A

SPECIFICATIONS	
AC Input: 100/120/220/230-240 VAC ±10%, 47-63 Hz.	
DC Output: 24-28 VDC regulated.	
Maximum Current Output: A-700: 0.5 A @ 60 Hz, 0.45 A @ 50 Hz; A-700-2: 2 A @ 60 Hz, 1.8 A @ 50 Hz; A-700-3: 4.8 A @ 60 Hz, 4.5 A @ 50 Hz.	
Operating Temperature: 32 to 122°F (0 to 50°C).	
External Fuse Required: 0.5 A for 100-120 VAC, 0.25 A for 220-240 VAC.	
Dimensions: 4-7/8" H x 4" W x 1-5/8" D.	
Weight: 2 lb.	

AC POWER TRANSFORMERS

20 VA to 150 VA, Single or Dual Hub, Circuit Breaker, UL Class 2



APT-40-3SN

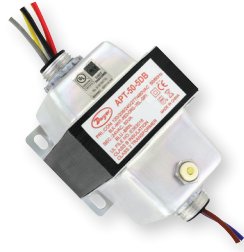

APT-50-5DB



APT-50-5SB

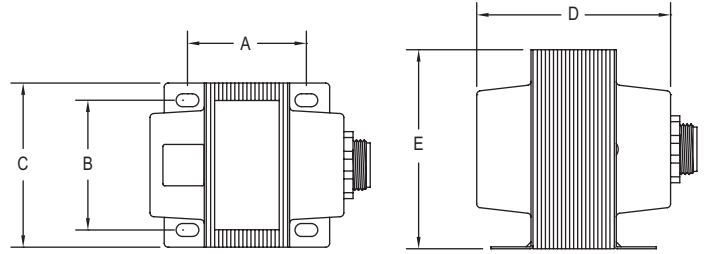

Model	Dimensions in [mm]				
	A	B	C	D	E
APT-20-0SN	1-31/64 (37.6)	1-21/32 (41.9)	1-7/8 (47.5)	2-17/64 (57.4)	2-39/64 (66.2)
APT-20-1SN	1-31/64 (37.6)	1-21/32 (41.9)	1-7/8 (47.5)	2-17/64 (57.4)	2-39/64 (66.2)
APT-40-3SN	1-61/64 (49.5)	1-25/32 (45.2)	2-11/64 (55.0)	2-43/64 (68.0)	2-7/8 (73.0)
APT-40-5DN	1-61/64 (49.5)	1-25/32 (45.2)	2-11/64 (55.0)	2-3/4 (70.0)	2-7/8 (73.0)
APT-50-5SB	1-13/16 (46.0)	1-31/32 (50.2)	2-1/2 (63.5)	3-7/16 (87.1)	3-1/32 (77.0)
APT-50-5DB	1-13/16 (46.0)	1-31/32 (50.2)	2-1/2 (63.5)	3-7/16 (87.1)	3-1/32 (77.0)
APT-75-5SB	2-13/64 (56.0)	1-31/32 (50.2)	2-1/2 (63.5)	3-53/64 (97.1)	3-1/32 (77.0)
APT-75-5DB	2-13/64 (56.0)	1-31/32 (50.2)	2-1/2 (63.5)	3-53/64 (97.1)	3-1/32 (77.0)
APT-100-5SB	2-39/64 (66.0)	1-31/32 (50.2)	2-1/2 (63.5)	4-1/4 (107.1)	3-1/32 (77.0)
APT-100-5DB	2-39/64 (66.0)	1-31/32 (50.2)	2-1/2 (63.5)	4-1/4 (107.1)	3-1/32 (77.0)
APT-150-1DB	2-33/64 (64.0)	1-31/32 (50.2)	2-1/2 (63.5)	3-9/16 (90.5)	3-1/32 (77.0)

The Series APT AC Power Transformers provide isolated step-down to 24 VAC with models offering VA ratings of 20, 40, 50, 75, 96, or 150 VAs. These cost efficient transformers are offered in single or dual 1/2" NPT threaded hub mounts with 8-1/2" 18 AWG wire leads, to meet the installation requirements of a variety of building automation and control panel applications in HVAC. All models are UL Class 2 listed.

FEATURES/BENEFITS

- Single or dual 1/2" NPT
- Universal supply voltage input
- With or without integral circuit breaker

APPLICATIONS

- BAS
- HVAC

SPECIFICATIONS

Input Voltage: See model chart.
Input Frequency: 50/60 Hz.
Output Voltage: See model chart.
Output VA Rating: 20, 40, 50, 75, 96, or 150 VA.
Mounting: Slotted foot mount with single, or dual 1/2" NPT hub.
Current Protection: See model chart.
Electrical Connections: Models ending in -20: 20" (508 mm) 18 AWG leads; All other models: 8.5" (210 mm) 18 AWG leads.
Weight: See model chart.
Agency Approvals: CE, cULus.

MODEL CHART

Model	Rating	Input Voltage	Output Voltage	Mounting	Current Protection	Wiring	Weight
APT-20-0SN	20 VA	24 VAC	24 VAC	Foot mount with single hub	Inherent	Diagram B	1.25 lb (0.57 kg)
APT-20-1SN	20 VA	120 VAC	24 VAC	Foot mount with single hub	Inherent	Diagram A	1.29 lb (0.59 kg)
APT-40-3SN	40 VA	120/208/240/277 VAC	24 VAC	Foot mount with single hub	Internal fuse	Diagram D	2.07 lb (0.94 kg)
APT-40-5DN	40 VA	120/208/240/277/480 VAC	24 VAC	Foot mount with single hub	Internal fuse	Diagram C	2.29 lb (1.04 kg)
APT-50-5SB	50 VA	120/208/240/277/480 VAC	24 VAC	Foot mount with single hub	Button circuit breaker	Diagram C	2.69 lb (1.22 kg)
APT-50-5DB	50 VA	120/208/240/277/480 VAC	24 VAC	Foot mount with dual hub	Button circuit breaker	Diagram C	2.73 lb (1.24 kg)
APT-75-5SB	75 VA	120/208/240/277/480 VAC	24 VAC	Foot mount with single hub	Button circuit breaker	Diagram C	3.60 lb (1.63 kg)
APT-75-5DB	75 VA	120/208/240/277/480 VAC	24 VAC	Foot mount with dual hub	Button circuit breaker	Diagram C	3.62 lb (1.64 kg)
APT-100-5SB	100 VA	120/208/240/277/480 VAC	24 VAC	Foot mount with single hub	Button circuit breaker	Diagram C	4.03 lb (1.83 kg)
APT-100-5DB	100 VA	120/208/240/277/480 VAC	24 VAC	Foot mount with dual hub	Button circuit breaker	Diagram C	4.05 lb (1.84 kg)
APT-150-1DB	150 VA	120 VAC	24 VAC	Foot mount with dual hub	Button circuit breaker	Diagram A	4.98 lb (2.26 kg)

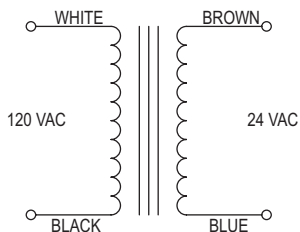

Diagram A

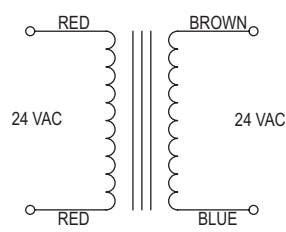

Diagram B

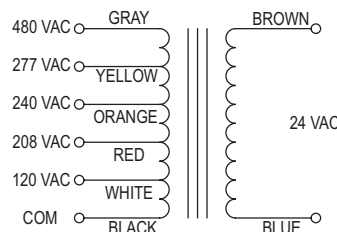

Diagram C

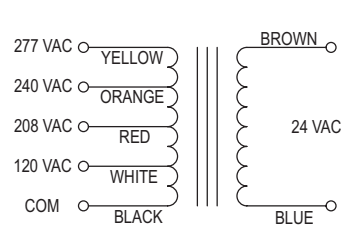
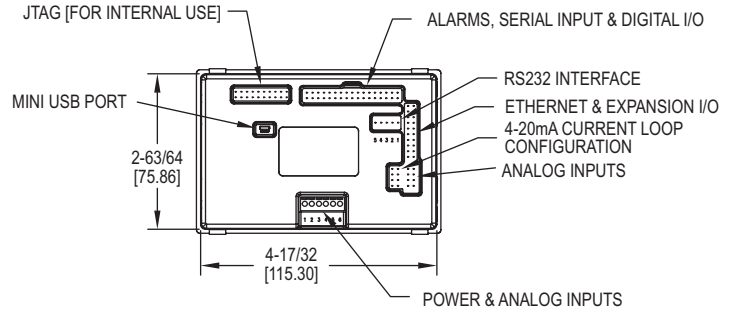
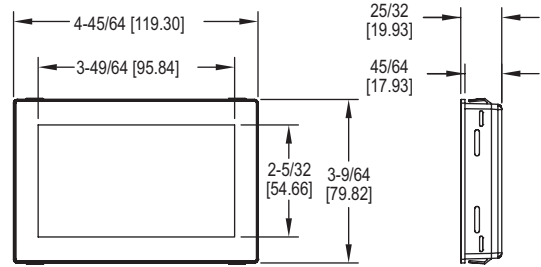

Diagram D

GRAPHICAL USER INTERFACE PANEL METER

4.3" (109 mm) Touch Screen Display, Fully Customizable



The Series SPPM2 Graphical User Interface Panel Meter is a configurable, full-color 4.3" (109 mm) touch screen display that can be used in a variety of applications. By using the free Windows® based Interface Panel Design Studio software, users can personalize the display with buttons, switches, and analog and digital scales to suit their needs. A development kit is also available, which includes a development board with buttons, dials, LEDs, and screw terminals to test the functionality of all inputs and outputs.

FEATURES/BENEFITS

- Large 4.3" touch screen display can be powered from USB or 5-30 VDC supply
- Free design software allows users to drag and drop elements onto the screen to quickly develop their specific interface
- Accepts up to 4 analog inputs, 8 digital I/O, 4 PWM outputs, and 2 open collector alarm outputs

APPLICATIONS

- Lift station pump control
- Room condition monitoring display
- Walk-in refrigeration/freezer control

MODEL CHART	
Model	Description
SPPM2-43	4.3" interface panel
SPPM2-43-D	4.3" interface panel with development board

SPECIFICATIONS

Inputs: Mini-USB, 6-line screw terminal analog, 4 x ±40 V, or 4-20 mA, 8 x digital I/O.
Outputs: 4 x PWM, 2 x alarms (open collector).
Accuracy: ±0.05% ±0.1 mV (typ).
Resolution: 0.04 mV (max) or 4 decimal places.
Power Supply: USB port or 5-30 VDC.
Current Consumption: 400 mA at 5 VDC.
Display: 4.3" (10.9 cm) TFT LCD with 262k colors.
Display Resolution: 480 x 272 pixels.
Sampling Rate: 10 samples/s.
Temperature Limits: 32 to 104°F (0 to 40°C).
Warm Up: 15 s.
Mounting: Panel mount.
Electrical Connection: Multi-pin DIL's, 1 mini-USB, and 1 RS232.
Software Requirements: Compatible with Windows® 7, Windows® 8 and Windows® 10.
Weight: 6.7 oz (181 g).
Approvals: CE.

DEVELOPMENT BOARD SPECIFICATIONS

Inputs: 4 x ±5 VDC.
Outputs: 8 x digital I/O's, 4 x PWM outputs.
Serial Communication: RS232.
Power Supply: USB port or 5-30 VDC.
Weight: 19.7 oz (560 g).

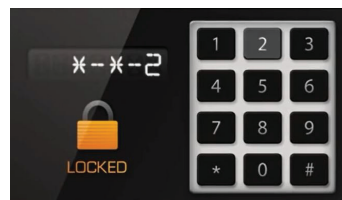
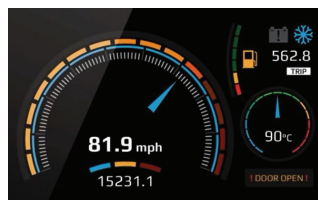
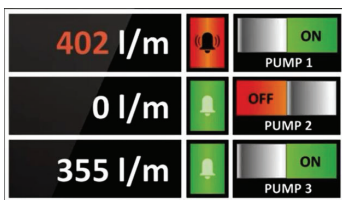

Windows® is a registered trademark of Microsoft Corporation.

SMART PROGRAMMABLE PANEL METERS

Fully Field Configurable, 16-Bit Color Touch Screen Display

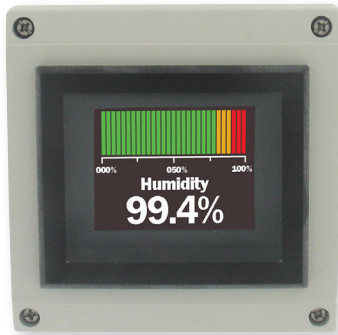

SPPM-HSG

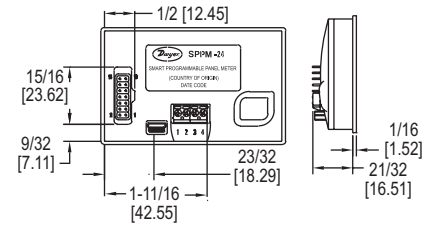
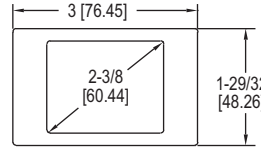

SPPM-24 and SPPM-24-C

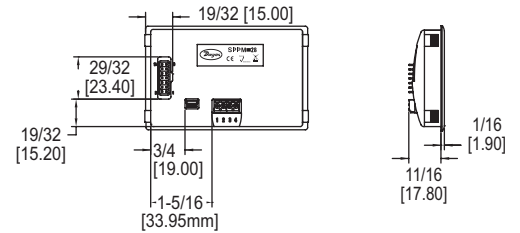
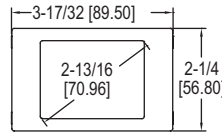

SPPM-28 and SPPM-28-C

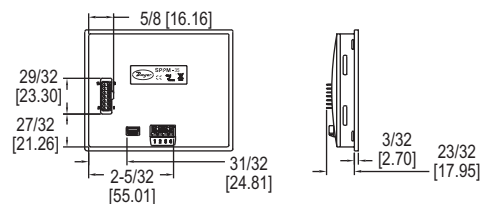
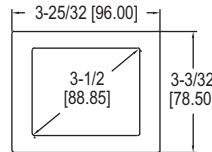

SPPM-35 and SPPM-35-C

The Series SPPM Smart Programmable Panel Meters are configurable full-color touch screen displays that can be used in a variety of applications. By using a USB connection, the panel meter can be configured with downloadable software for any computer running Windows® based software. The display features remarkable graphics that can easily be customized to read and/or graph pressure, temperature, humidity, gas concentration, or many other parameters.

FEATURES/BENEFITS

- Available with 2.4", 2.8", or 3.5" color touch screen display
- Free downloadable Windows® software allows the unit to be customized to specific applications

APPLICATIONS

- Tank level
- Power monitoring
- Room pressurization condition
- Indoor air quality conditions

SAMPLE PROGRAMMABLE DISPLAY CONFIGURATIONS

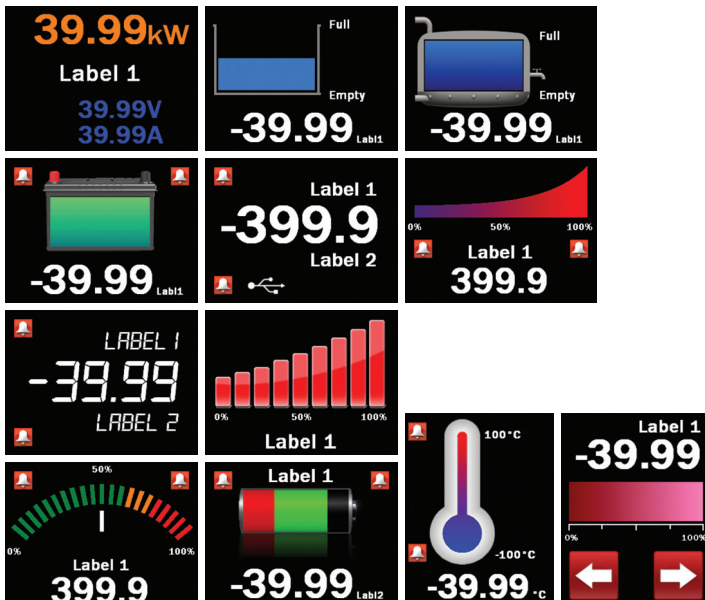

SPECIFICATIONS

SPPM SPECIFICATIONS

Inputs: Current: 0-50 mA, scalable (factory set from 4-20 mA); Voltage: 0-40 VDC, scalable (factory set from 0-10 V).
Accuracy: 0.1%.
Resolution: 0.3 to 9.8 mV (depending on input range).
Power Supply: 4-30 VDC max or via USB.
Current Consumption: 190 mA max.
Display: 2.4", 2.8" or 3.5" TFT full color touch screen.
Display Resolution: 320 x 240 pixels.
Sampling Rate: 3 samples/s.
Temperature Limits: 32 to 104°F (0 to 40°C).
Warm Up: 30 s.
Mounting: Panel mount.
Electrical Connection: Screw terminals, pin connection, or USB.
Computer Requirements: Compatible with Windows® 7, Windows® 8 and Windows® 10.
Weight: 2.8 oz (79.4 g).
Agency Approvals: CE.

SPPM-HSG SPECIFICATIONS

Service: Indoor or outdoor.
Material: Painted aluminum or glass.
Enclosure Rating: NEMA 4X (IP66).
A-SPPM-TC SPECIFICATIONS
Probe Measurement Range:
 K-type: -328 to 2462°F (-200 to 1350°C);
 J-type: -328 to 2174°F (-200 to 1190°C);
 T-type: -328 to 734°F (-200 to 390°C).
Temperature Limits: 14 to 104°F (-10 to 40°C).
Resolution: 1.0°F (0.5°C).
Power Requirements: Powered by USB port through SPPM panel meter.
Accuracy: ±2.0°F (±1.0°C).
Weight: 0.9 oz (25.5 g).
Agency Approvals: CE.

MODEL CHART

Model	Display	Input
SPPM-24	2.4"	Voltage
SPPM-28	2.8"	Voltage
SPPM-35	3.5"	Voltage
SPPM-24-C	2.4"	Current
SPPM-28-C	2.8"	Current
SPPM-35-C	3.5"	Current

ACCESSORIES

Model	Description
A-SPPM-TC	Thermocouple input board
SPPM-CA	Mini USB to full USB cable
SPPM-HSG24	2.4" display housing
SPPM-HSG28	2.8" display housing

Note: Additional configurations available via online software.



SERIES DPMA, DPMW, DPMP, & DPML

LCD DIGITAL PANEL METERS

3-1/2 & 4-1/2 Digit LCD, User Selectable Engineering Units, Panel Mount



DPMA

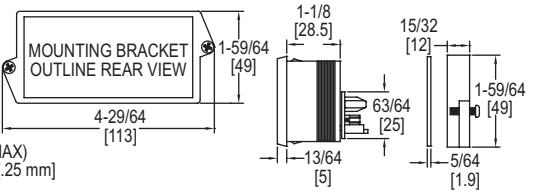
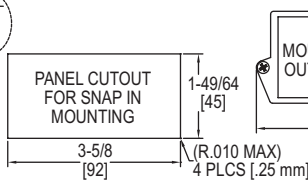
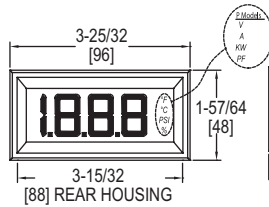

DPMW

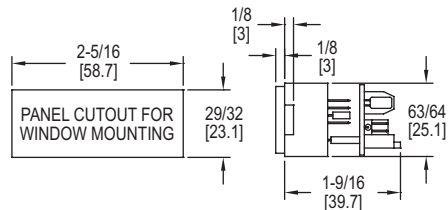
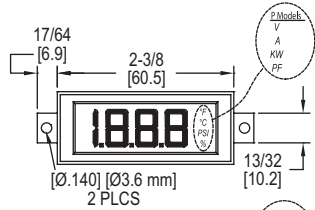

DPMP

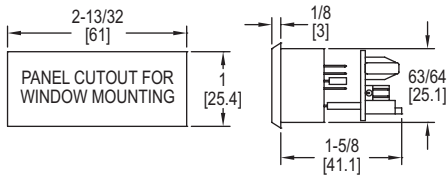
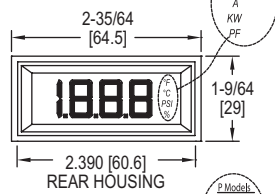

DPML

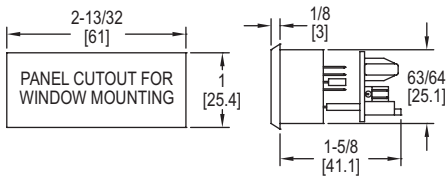
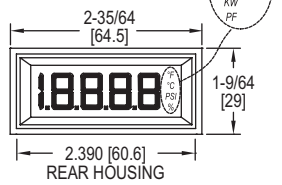

The Series DPMA, DPMW, DPMP, & DPML LCD Digital Panel Meters provide easy viewing on the 3-1/2 or 4-1/2 digit LCD display. On the DPMP and DPML the snap-in bezel mount eliminates mounting hardware for quick installation. The DPMA has a high contrast display for easy viewing in a standard 1/8 DIN package. The DPMW window mounts using two screws to sit flush within the panel cutout. This series can accept 4-20 mA, 0-200 mVDC, 0-5 VDC, or 0-10 VDC input signal and requires a 24 VDC power supply to illuminate the colored segments.

FEATURES/BENEFITS

- Panel mount for quick installation
- 3-1/2 or 4-1/2 digit with 0.45" or 1" segments
- Colored segments available in black, red, amber, green, or blue
- Jumper selectable engineering units and decimal point positions

APPLICATIONS

- Display process values from pressure, humidity, temperature, voltage, current, watt, or power factor transmitters

ACCESSORIES

Model	Description
DPM-12P	Regulated 120 VAC to 12 VDC power supply
DPM-24P	Regulated 120 VAC to 24 VDC power supply

SPECIFICATIONS

Input: DPMX-4XX(P): 4-20 mA; DPMX-5XX(P): 0-200 mVDC, 0-5 VDC, or 0-10 VDC.
Input Impedance: DPMX-4XX(P): 300Ω nominal; DPMX-5XX(P): 390Ω nominal.
Accuracy: DPMA: ±(0.05% FS + 1 count); DPMW/P/L: ±(0.1% FS + 2 count).
Power Supply: DPMX-4XX(P): Powered by control loop; DPMX-5XX(P): 12 VDC or 24 VDC.
Backlight Power Supply: 24 VDC @ 35 mA typical.
Span and Zero: Adjustable (±1999 counts).
Display: DPMA: 3-1/2 digits, 7 segments, 1" (25.4 mm) H; DPMP/W: 3-1/2 digits, 7 segments, 0.45" (11.4 mm) H; DPML: 4-1/2 digits, 7 segments, 0.45" (11.4 mm) H.

Decimal Points: DPMA/W/P: 3-position, user selectable; DPML: 4-position, user selectable.
Polarity: Automatic, "-" displayed.
Operating Temperature: 32 to 122°F (0 to 50°C).
Storage Temperature: -4 to 158°F (-20 to 70°C).
Mounting: DPMA: Snap-in panel mount or clamp (gasket included); DPMW: Window mount; DPMP/L: Snap-in bezel mount.
Connection: Screw terminals.
Conversion Rate: 3 per s.
Warm-Up: 10 minutes typical.
Weight: DPMA: 4 oz (113.4 g); DPMW/P/L: 2 oz (56.7 g).

MODEL CHART

Model	Input	Segments	Engineering Units	Digit	Model	Input	Segments	Engineering Units	Digit
DPMA-401	Current	Amber	°F, °C, %, psi	3-1/2"	DPMW-401P	Current	Amber	V, A, KW, PF	3-1/2"
DPMA-402	Current	Red	°F, °C, %, psi	3-1/2"	DPMW-402P	Current	Green	V, A, KW, PF	3-1/2"
DPMA-404	Current	Green	°F, °C, %, psi	3-1/2"	DPMW-403P	Current	Red	V, A, KW, PF	3-1/2"
DPMA-501	Voltage	Amber	°F, °C, %, psi	3-1/2"	DPMP-401*	Current	Amber	°F, °C, %, psi	3-1/2"
DPMA-502	Voltage	Red	°F, °C, %, psi	3-1/2"	DPMP-402*	Current	Green	°F, °C, %, psi	3-1/2"
DPMA-504	Voltage	Green	°F, °C, %, psi	3-1/2"	DPMP-403*	Current	Red	°F, °C, %, psi	3-1/2"
DPMA-401P	Current	Amber	V, A, KW, PF	3-1/2"	DPMP-501*	Voltage	Amber	°F, °C, %, psi	3-1/2"
DPMA-402P	Current	Red	V, A, KW, PF	3-1/2"	DPMP-502*	Voltage	Green	°F, °C, %, psi	3-1/2"
DPMA-404P	Current	Green	V, A, KW, PF	3-1/2"	DPMP-503*	Voltage	Red	°F, °C, %, psi	3-1/2"
DPMA-501P	Voltage	Amber	V, A, KW, PF	3-1/2"	DPMP-401P*	Current	Amber	V, A, KW, PF	3-1/2"
DPMA-502P	Voltage	Red	V, A, KW, PF	3-1/2"	DPMP-402P*	Current	Green	V, A, KW, PF	3-1/2"
DPMA-504P	Voltage	Green	V, A, KW, PF	3-1/2"	DPMP-403P*	Current	Red	V, A, KW, PF	3-1/2"
DPMW-401	Current	Amber	°F, °C, %, psi	3-1/2"	DPMP-501P*	Voltage	Amber	V, A, KW, PF	3-1/2"
DPMW-402	Current	Green	°F, °C, %, psi	3-1/2"	DPMP-502P*	Voltage	Green	V, A, KW, PF	3-1/2"
DPMW-403	Current	Red	°F, °C, %, psi	3-1/2"	DPMP-503P*	Voltage	Red	V, A, KW, PF	3-1/2"

*For 4-1/2 digit display, change DPMP to DPML. Example: DPML-401

EXTRA LARGE DIGITAL PANEL METER

3-1/2 Digit LED Display, 2.3" Segment Height, Process Inputs

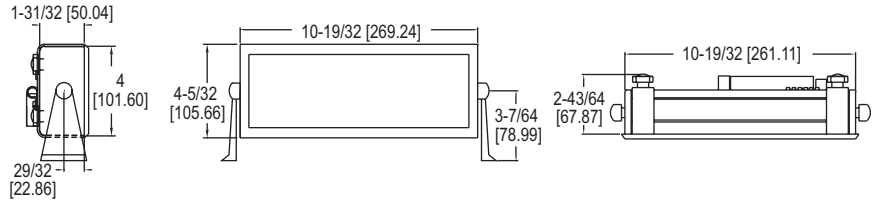

The Series DPMX Extra Large Digital Panel Meter can be easily viewed from across a room or in dark areas. The 2.3" LED segments are available in red, green, or blue. These panel meters come equipped with a universal power supply and user selectable process inputs to fit most applications.

FEATURES/BENEFITS

- Large 10.6" (269.2 mm) x 4.2" (105.7 mm) backlit display
- Protective metal casing with adjustable mounting bracket

APPLICATIONS

- Display process values from various transmitters

MODEL CHART		
Model	Segments	Power Supply
DPMX-1	Blue	90-250 VAC
DPMX-2	Green	90-250 VAC
DPMX-3	Red	90-250 VAC
DPMX-1-LV	Blue	10.5-30 VAC/VDC
DPMX-2-LV	Green	10.5-30 VAC/VDC
DPMX-3-LV	Red	10.5-30 VAC/VDC

SPECIFICATIONS

Inputs: Set voltage: ± 200 mVDC, ± 2 VDC, ± 20 VDC; Adjustable voltage: 200 mVDC, 5 VDC, 10 VDC; Adjustable current: 0(4)-20 mA DC.
Input Impedance: Set voltage: >1 M Ω (>10 M Ω on 200 mV range); Adjustable voltage: 392 k Ω ; Adjustable current: 300 Ω nominal.
Accuracy: $\pm(1\%$ FS + 1 count).
Power Supply: 90-250 VAC @ 12 VA or 10.5-30 VAC/DC @ 6 VA (depending on model).
Display: 3-1/2 digits, 2.3" H, 7 segment LED.
Sampling Rate: 3 readings per s.
Operating Temperature: 14 to 122°F (-10 to 50°C).
Storage Range: -40 to 167°F (-40 to 75°C).
Warm Up: 10 minutes.
Mounting: 180° gimbal mounting with 30° stops or bezel mount.

SERIES LCI132

COMPACT PROCESS INDICATOR

1/32 DIN, Fully Programmable



Process display

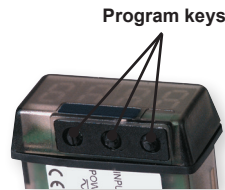

Program keys

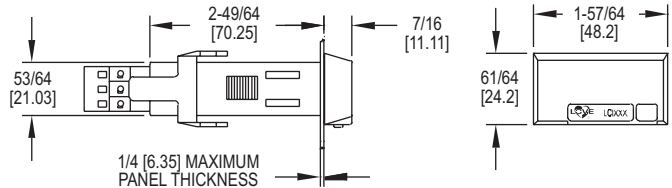

The Series LCI132 Compact Process Indicator offers flexibility and value in a low cost, compact 1/32 DIN package. The shallow depth of these full size panel meters allows installation in panels only 2.76" (70 mm) deep with room to spare.

FEATURES/BENEFITS

- Fits in 1/32 DIN panel cutouts
- IP65 (NEMA 4X) front housing
- Fully programmable
- Various voltage and current inputs fit most processes

APPLICATIONS

- Display process values from various transmitters

MODEL CHART		
Model	Input	Supply Voltage
LCI132-00	± 100 VDC; ± 20 VDC; ± 10 VDC; ± 200 VDC; ± 20 mA DC	120/240 VAC
LCI132-01	± 100 VDC; ± 20 VDC; ± 10 VDC; ± 200 VDC; ± 20 mA DC	24/48 VAC
LCI132-10	± 100 VAC; 600 VAC; 5 A (DC) 1 A (AC); -199.9 to +600 VDC; ± 100 VDC -1.999 to 5 A (DC) ± 1 A (DC)	120/240 VAC
LCI132-11	± 100 VAC; 600 VAC; 5 A (DC) 1 A (AC); -199.9 to +600 VDC; ± 100 VDC -1.999 to 5 A (DC) ± 1 A (DC)	24/48 VAC

SPECIFICATIONS

LCI132-0X
Range: Input volts (DC): ± 200 V, ± 20 V, ± 10 V; Input amperes: ± 100 mV, ± 20 mA.
Resolution: Input volts (DC): 0.1 V, 0.01 V, 1 mV; Input amperes: 0.1 mV, 0.01 mA; Input impedance: Volts: 1 M Ω , mV: 100 M Ω , mA: 12.1 Ω .
LCI132-1X
Range AC: Input volts: 600.0, 100.0; Input amperes: 5.000, 1.000.
Range DC: Input volts: -199.9, ± 600.0 , ± 100.0 ; Input amperes: -1.999, +5.000, ± 1.000 .
Resolution: Input volts: 0.1 V; Input amperes: 1 mA; Input impedance: Volts: 3 M Ω (106), Amps: 12 m Ω (10-3).
Accuracy at 23°C $\pm 5^\circ$ C: 100/600 VDC 1/5 A DC; 600 V/5 A AC: $\pm(0.2\%$ reading + 3 digits). 100 V / 1 A AC: $\pm(0.4\%$ reading + 4 digits).
Temperature Coefficient: 100 ppm/ $^\circ$ C.
Warm Up: 5 minutes.
Power Supply and Fuses (DIN 41661) (Not supplied): LCI132-X0: 85–265 VAC 50/60 Hz and 100-300 VDC; Fuse: 0.1 A/ 250 V; LCI132-X1: 21-53 VAC 50/60 Hz and 10.5-70 VDC; Fuse 0.5 A/ 250 V.
DISPLAY
Range: -1999 to 9999 (DC) 0 to 9999 (AC).
Type: 4 red digits 10 mm.
Reading Rate: 4/s.
Overflow Indication: OVR.
ENVIRONMENTAL
Operating Temperature: 14 to 140°F (-10 to 60°C).
Storage Temperature: -13 to 185°F (-25 to 85°C).
Relative Humidity (non condensed): < 95% @ 40°C.
Panel Sealing: NEMA 4X (IP66).

ELECTROMECHANICAL RELAYS

30 Amp, SPDT and DPDT Operation

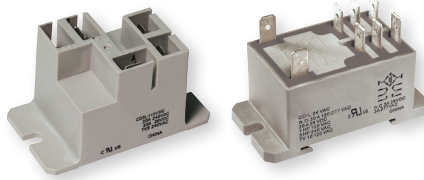

SPDT

DPDT

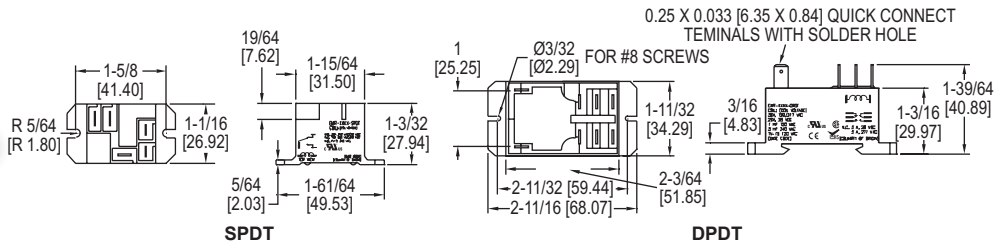

The Series 9 Electromechanical Relays are small in size, features Class F insulation for a max coil temperature of 155°C, quick-connect terminals for simple connection, and is panel mountable. The relays are compact and impervious to shock and vibration.

FEATURES/BENEFITS

- Compact size for flange mounting
- Quick-connect terminals to allow for easy installation

APPLICATIONS

- Motor control
- Lighting control
- Refrigeration compressor systems

Model	Operation	Input Voltage	Coil Resistance
9AS5A5224	AC	24 VAC 50/60 Hz	500 Ω
9AS5A52120	AC	120 VAC 50/60 Hz	3000 Ω
92S11A22D24	AC	24 VAC 50/60 Hz	250 Ω
92S11A22D120	AC	120 VAC 50/60 Hz	1600 Ω
9AS5D5224	DC	24 VDC	576 Ω
92S11D22D12	DC	12 VDC	86 Ω
92S11D22D24	DC	24 VDC	1600 Ω

SPECIFICATIONS

<p>Operating and Load Voltage Range: 12-277 VAC; 5-110 VDC.</p> <p>Electrical Connection: Quick-connect tab terminals. SPDT 0.187" coil terminal/0.25" contact terminal; DPDT 0.25" coil terminal/0.25" contact terminal.</p> <p>Switching Operation: SPDT or DPDT.</p> <p>Electrical Rating: SPDT: NO 30 A @ 240 VAC / 28 VDC; NC 10 A @ 240 VAC / 28 VDC; DPDT: 30 A @ 240 VAC 20 A @ 28 VDC.</p>	<p>Temperature Limits: Storage: -40 to 185°F (-40 to 85°C); Operation: -40 to 131°F (-40 to 55°C).</p> <p>Voltage Loss: 2.5 VA (VAC); 1W (VDC).</p> <p>Cycle Life: 100,000 cycles (electrical); 10,000,000 cycles (mechanical).</p> <p>Housing: Polyester resin.</p> <p>Weight: 1.16 oz (45 g) (SPDT); 3 oz (85 g) (DPDT).</p> <p>Agency Approvals: CE, cULus, (EMR-XXXX-DPDT), cURus (EMR-XXXX-SPDT).</p>
---	--

ACCESSORIES

Model	Description
16-9ADIN1	Din adaptor
A-360	Aluminum DIN rail 1 m

SERIES 781 & 782

ICE CUBE RELAYS

SPDT or DPDT Operation

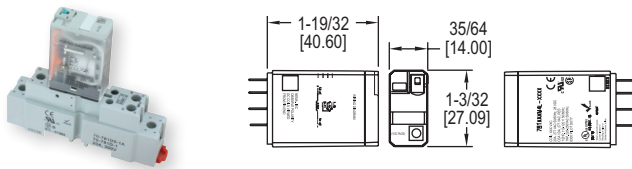

781

Pictures shown with socket accessory (sold separately)

782

The Series 781 & 782 Ice Cube Relays are full-featured relays that can be used to handle loads up to 15 amps for AC or DC circuits. It features a flag status indicator and a LED status lamp to let the user know when the relay is activated. In order to differentiate between AC and DC actuated models, the push-to-test button is color coded and a removable lock-down lever holds the test button in place.

FEATURES/BENEFITS

- Clear plastic housing to easily view the contacts
- Flag and LED status indicators for visual confirmation of relay state
- Socket mounted for quick installation/replacement

APPLICATIONS

- Refrigeration compressor systems
- HVAC motor controls
- Water/wastewater pump control

SPECIFICATIONS

<p>Operating and Load Voltage Range: 24-240 VAC; 24 VDC.</p> <p>Electrical Connection: Silver alloy plug-in contacts.</p> <p>Switching Operation: SPDT or DPDT.</p> <p>Electrical Rating: Depends on model, see model chart.</p> <p>Temperature Limits: Storage: -40 to 185°F (-40 to 85°C); Operation: -40 to 131°F (-40 to 55°C).</p>	<p>Power Consumption: 781: 0.9 VA; 0.7W; 782: 1.2 VA; 0.9W.</p> <p>Cycle Life: 100,000 cycles (electrical); 10,000,000 cycles (mechanical).</p> <p>Housing: Plastic polycarbonate.</p> <p>Weight: 781: 1.02 oz (29 g); 782: 1.3 oz (36 g).</p> <p>Agency Approvals: CE, CSA, cULus, cURus.</p>
--	---

ACCESSORIES

Model	Description
70-781D5-1A	Socket for 781 series relay
70-782D8-1A	Socket for 782 series relay

Model	Operation	Input Voltage	Coil Resistance	Electrical Rating
781XAXRM4L-24A	AC	24 VAC 50/60 Hz	180 Ω	15 A @ 277 VAC (50/60 Hz) or 28 VDC
781XAXRM4L-120A	AC	120 VAC 50/60 Hz	4430 Ω	15 A @ 277 VAC (50/60 Hz) or 28 VDC
781XAXRM4L-240A	AC	240 VAC 50/60 Hz	15720 Ω	15 A @ 277 VAC (50/60 Hz) or 28 VDC
781XAXRM4L-24D	DC	24 VDC	750 Ω	15 A @ 277 VAC (50/60 Hz) or 28 VDC
782XBXM4L-24A	AC	24 VAC 50/60 Hz	180 Ω	15 A @ 120 VAC 50/60 Hz; 12 A @ 277 VAC 50/60 Hz or 28 VDC (UL); 10 A @ 277 VAC 50/60 Hz (CSA)
782XBXM4L-120A	AC	120 VAC 50/60 Hz	4430 Ω	15 A @ 120 VAC 50/60 Hz; 12 A @ 277 VAC 50/60 Hz or 28 VDC (UL); 10 A @ 277 VAC 50/60 Hz (CSA)
782XBXM4L-240A	AC	240 VAC 50/60 Hz	15720 Ω	15 A @ 120 VAC 50/60 Hz; 12 A @ 277 VAC 50/60 Hz or 28 VDC (UL); 10 A @ 277 VAC 50/60 Hz (CSA)
782XBXM4L-24D	DC	24 VDC	650 Ω	15 A @ 120 VAC 50/60 Hz; 12 A @ 277 VAC 50/60 Hz or 28 VDC (UL); 10 A @ 277 VAC 50/60 Hz (CSA)

GALVANNEALED STEEL ENCLOSURES

Wall Mounted, NEMA 3R, UL Approved

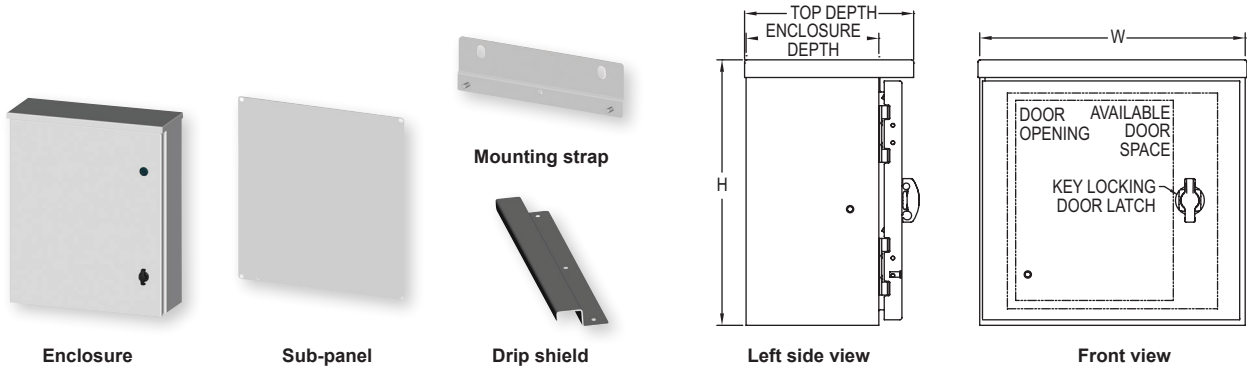

The Series CSE-3R Galvanized Steel Enclosures are spot-welded, wall mounted enclosures designed to house electrical controls, instruments, and components in an outdoor environment. These units are made of carbon steel, NEMA 3R outdoor environment rated and carry a UL approval.

FEATURES/BENEFITS

- Concealed hinges that allow 180° of rotation for easy instrumentation access
- Quarter turn latch that can be opened/closed with a screwdriver, and ground studs on the door and body
- Mounting holes on the back of the enclosure allow for versatile mounting and standoffs provide easy installation of optional sub-panels. A rain cap and an oil resistant door gasket will protect instruments from rain, sleet, and snow. Each unit includes a 3/8-16 grounding kit and has the option of including a sub-panel, mounting strap, and/or a drip shield. This series is the perfect accessory for a variety of instrumentation in need of outdoor protection

APPLICATIONS

- HVAC indoor applications
- Housing general controls and gages

SPECIFICATIONS	
Materials:	Galvanized steel enclosure; All other components: Carbon steel.
Rating:	NEMA 3R (IP32).
Dimensions:	See chart for enclosure dimensions; Sub-panel height = enclosure height - 3" (76 mm); Sub-panel width = enclosure width - 3" (76 mm); Mounting strap width = enclosure width - 4" (102 mm); Drip shield width = enclosure width.
Thickness:	0.048" (1.22 mm) for drip shields; 0.060" (1.52 mm) for enclosures < 24" wide; 0.075" (1.91 mm) for enclosures ≥ 24" wide; 0.125" (3.18 mm) for sub-panels; 0.078" (1.98 mm) for mounting straps.
Weight:	See chart.
Agency Approvals:	CSA, cULus. (Meets the technical requirements of EU Directive 2011/65/EU (RoHS II)).

MODEL CHART										
Enclosure* Model	Height in (cm)	Width in (cm)	Depth in (cm)	Weight lb (kg)	Sub Panel* Model	Weight lb (kg)	Mounting Strap* Model	Weight lb (kg)	Drip Shield* Model	Weight lb (kg)
CSE-3R-121206	12 (30)	12 (30)	6 (15)	15 (7)	A-SSE-P-1212	3 (1.4)	A-CSE-3M-12	2 (0.9)	A-CSE-D-12	2 (0.9)
CSE-3R-161206	16 (41)	12 (30)	6 (15)	16 (7)	A-SSE-P-1612	4 (1.8)	A-CSE-3M-16	2 (0.9)	A-CSE-D-16	2 (0.9)
CSE-3R-201606	20 (51)	16 (41)	6 (15)	25 (11)	A-SSE-P-2016	8 (3.6)	A-CSE-3M-20	3 (1.4)	A-CSE-D-20	3 (1.4)
CSE-3R-242006	24 (61)	20 (51)	6 (15)	32 (15)	A-SSE-P-2420	14 (6.4)	A-CSE-3M-24	4 (1.8)	A-CSE-D-24	4 (1.8)
CSE-3R-302408	30 (76)	24 (61)	8 (20)	60 (27)	A-SSE-P-3024	22 (10)			A-CSE-D-30	4 (1.8)
CSE-3R-362408	36 (91)	24 (61)	8 (20)	62 (28)	A-SSE-P-3624	27 (12.2)				
CSE-3R-363008	36 (91)	30 (76)	8 (20)	70 (32)	A-SSE-P-3630	34 (15.4)				

*For additional sizes contact factory.

ACCESSORIES	
Model	Description
A-CSE-L	Keylocking wing knob door latch, Includes 1 lock and 2 keys
A-CSE-K	Replacement keys, includes 2 keys



A-CSE-L



SERIES CSE-N1 & CSE-KN



CARBON STEEL ENCLOSURES

Wall Mounted, General Purpose Enclosure, UL Approved

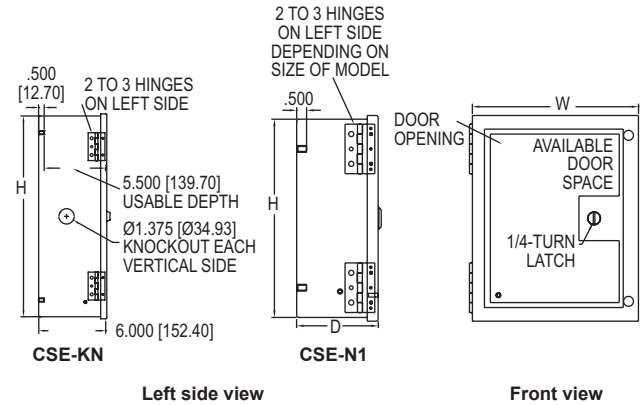
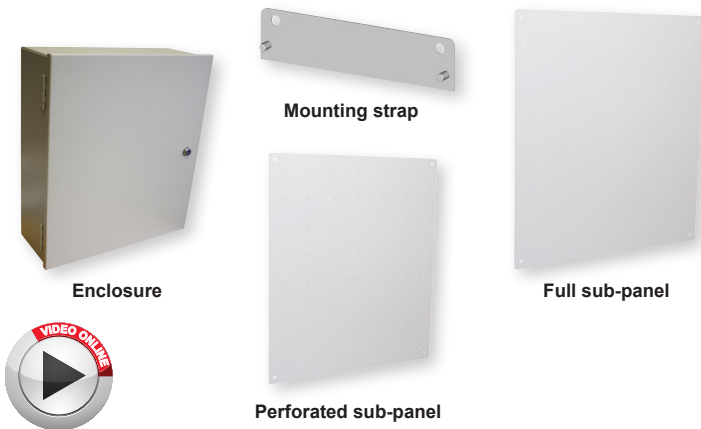

The Series CSE-N1 & CSE-KN Carbon Steel Enclosures are spot-welded, wall mounted, general purpose enclosures designed to house electrical controls, instruments, and components in general purpose areas. The Series CSE-KN also includes knockouts to allow cords to pass easily into the unit.

FEATURES/BENEFITS

- The door features hinges that allow 180° of rotation for easy instrumentation access
- Quarter turn latch can easily opened or closed with a screwdriver
- Included ground stud for easy electrical grounding
- Mounting holes included on the back of the enclosure allow for versatile mounting and standoffs provide easy installation of optional sub-panels
- Each unit offers optional solid or perforated sub-panel and mounting straps for easy instrument mounting
- The CSE-KN series includes a sub-panel with a 2" x 2" (50.8 mm x 50.8 mm) mounting grid mounted on standoffs and lock with keys

APPLICATIONS

- HVAC indoor applications
- Housing general controls and gages
- Securing instrumentation and avoiding tampering

SPECIFICATIONS

Materials: Carbon steel.
Rating: NEMA 1.
Dimensions: See chart.
Thickness: 0.060" (1.52 mm) for enclosures <24" wide; 0.075" (1.91 mm) for enclosures ≥ 24" wide; 0.060" (1.52 mm) for perforated sub-panels; 0.075" (1.91 mm) for solid sub-panels; 0.078" (1.98 mm) for mounting straps.
Weight: See chart.
Agency Approvals: CSA, cULus. (Meets the technical requirements of EU Directive 2011/65/EU (RoHS II)).

MODEL CHART												
Enclosure* Model	Height in (cm)	Width in (cm)	Depth in (cm)	Weight lb (kg)	Sub-Panel* Model**	Height in (cm)	Width in (cm)	Weight lb (kg)	Sub-Panel* Model**	Height in (cm)	Width in (cm)	Weight lb (kg)
CSE-N1-100804	10 (25)	8 (20)	4 (10)	7 (3.2)	A-CSE-1S-1008	8 (20)	6 (15)	2 (0.9)	A-CSE-1S-2016	18 (46)	14 (36)	6 (2.7)
CSE-N1-101004	10 (25)	10 (25)	4 (10)	8.5 (3.9)	A-CSE-1P-1008	8 (20)	6 (15)	1 (0.5)	A-CSE-1P-2016	18 (46)	14 (36)	3 (1.4)
CSE-N1-121004	12 (30)	10 (25)	4 (10)	5 (2.3)	A-CSE-1S-1010	8 (20)	8 (20)	1 (0.5)	A-CSE-1S-2020	18 (46)	18 (46)	7 (3.2)
CSE-N1-121204	12 (30)	12 (30)	4 (10)	10 (4.5)	A-CSE-1P-1010	8 (20)	8 (20)	1 (0.5)	A-CSE-1P-2020	18 (46)	18 (46)	4 (1.8)
CSE-N1-141204	14 (36)	12 (30)	4 (10)	10 (4.5)	A-CSE-1S-1210	10 (25)	8 (20)	3 (1.4)	A-CSE-1S-2416	22 (56)	14 (36)	7 (3.2)
CSE-N1-161206	16 (41)	12 (30)	6 (15)	11 (5)	A-CSE-1P-1210	10 (25)	8 (20)	1 (0.5)	A-CSE-1P-2416	22 (56)	14 (36)	5 (2.3)
CSE-N1-161606	16 (41)	16 (41)	6 (15)	16 (7.3)	A-CSE-1S-1212	10 (25)	10 (25)	4 (1.8)	A-CSE-1S-2420	22 (56)	18 (46)	9 (4.1)
CSE-N1-201606	20 (51)	16 (41)	6 (15)	21 (9.5)	A-CSE-1P-1212	10 (25)	10 (25)	2 (0.9)	A-CSE-1P-2420	22 (56)	18 (46)	7 (3.2)
CSE-N1-202006	20 (51)	20 (51)	6 (15)	25 (11.3)	A-CSE-1S-1412	12 (30)	10 (25)	3 (1.4)	A-CSE-1S-2424	22 (56)	22 (56)	11 (5)
CSE-N1-241606	24 (61)	16 (41)	6 (15)	27 (12.2)	A-CSE-1P-1412	12 (30)	10 (25)	2 (0.9)	A-CSE-1P-2424	22 (56)	22 (56)	8 (3.6)
CSE-N1-242006	24 (61)	20 (51)	6 (15)	31.5 (14.3)	A-CSE-1S-1612	14 (36)	10 (25)	3 (1.4)	A-CSE-1S-3024	28 (71)	22 (56)	13 (6)
CSE-N1-242406	24 (61)	24 (61)	6 (15)	41 (18.6)	A-CSE-1P-1612	14 (36)	10 (25)	2 (0.9)	A-CSE-1P-3024	28 (71)	22 (56)	11 (5)
CSE-N1-302406	30 (76)	24 (61)	6 (15)	54 (24.5)	A-CSE-1S-1616	14 (36)	14 (36)	4 (1.8)	A-CSE-1S-3030	28 (71)	28 (71)	17 (8)
CSE-N1-303008	30 (76)	30 (76)	8 (20)	60 (27.2)	A-CSE-1P-1616	14 (36)	14 (36)	2 (0.9)	A-CSE-1P-3030	28 (71)	28 (71)	14 (6)

*For additional sizes contact factory. **1S denotes a solid steel panel; 1P denotes a perforated steel panel.

MODEL CHART		
Mounting Strap* Model	Width in (cm)	Weight lb (kg)
A-CSE-1M-08	7.1 (18)	1 (0.5)
A-CSE-1M-10	9.1 (23)	1 (0.5)
A-CSE-1M-12	11.1 (28)	1 (0.5)
A-CSE-1M-16	15.1 (38)	2 (0.9)
A-CSE-1M-20	19.1 (49)	2 (0.9)
A-CSE-1M-24	23.1 (59)	3 (1.4)

*For additional sizes contact factory.

MODEL CHART							
Enclosure Model	Height in (cm)	Width in (cm)	Depth in (cm)	Weight lb (kg)	Mounting Strap Model	Width in (cm)	Weight lb (kg)
CSE-KN-181606	18 (46)	16 (41)	6 (15)	22 (10)	A-CSE-1M-16	15.1 (38)	2 (0.9)
CSE-KN-242006	24 (61)	20 (51)	6 (15)	35 (16)	A-CSE-1M-20	19.1 (49)	2 (0.9)
CSE-KN-362406	36 (91)	24 (61)	6 (15)	58 (26)	A-CSE-1M-24	23.1 (59)	3 (1.4)

ACCESSORIES	
Model	Description
A-CSE-L	Keylocking wing knob door latch, includes 1 lock and 2 keys
A-CSE-K	Replacement keys, includes 2 keys



A-CSE-L

STATIC PRESSURE TIPS

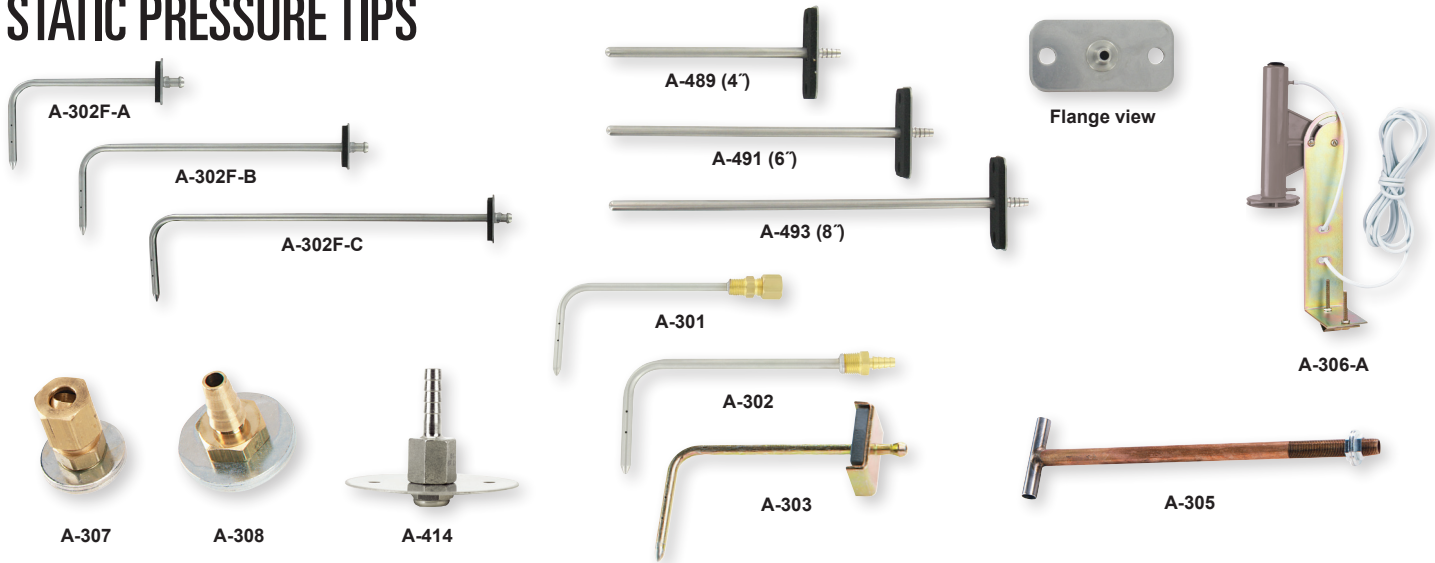

MODEL CHART	
Model	Description
The stainless steel static pressure tips are used to measure static pressures in ducts or rooms. They are to be connected to differential pressure switches and transmitters. Two static sensors are used in applications where differential pressure is required across a filter or coil. These sensors include a mounting flange with integral rubber gasket and two screws for simplifying mounting on a duct.	
A-302F-A	4" hook style SS static pressure tip with mounting flange
A-302F-B	6" hook style SS static pressure tip with mounting flange
A-302F-C	8" hook style SS static pressure tip with mounting flange
A-489	4" straight SS static pressure tip with mounting flange
A-491	6" straight SS static pressure tip with mounting flange
A-493	8" straight SS static pressure tip with mounting flange
Designed for simplified installation, these are easy to install, inexpensive, and provides accurate static pressure sensing in smooth air at velocities up to 1500 FPM.	
A-307	Static pressure fitting, for 1/4" metal tubing connection
A-307-SS	SS static pressure fitting, for 1/4" metal tubing connection
A-308	Static pressure fitting, for 3/16" and 1/8" ID plastic or rubber tubing
A-414	SS clean room pressure sensor
These static pressure tips are ideal for applications such as sensing the static pressure drop across industrial air filters and refrigerant coils. Here the probability of air turbulence requires that the pressure sensing openings be located away from the duct walls to minimize impingement and aspiration, and thus ensure accurate readings. For a permanent installation of this type, the Dwyer No. A-301 or A-302 static pressure tip is used. It senses static pressure through radially-drilled holes near the tip and can be used in air flow velocities up to 12,000 FPM. The angled tips shown have 4" insertion depth. Each has four radially drilled .040" sensing holes. All except Model A-303 mount in 3/8" hole in duct. For portable use, a magnet holds No. A-303 in place.	
A-301	Static pressure tip, for 1/4" metal tubing connection
A-301-A	Static pressure tip, same as A-301 with 6" insertion depth
A-301-B	Static pressure tip, same as A-301 with 8" insertion depth
A-301-C	Static pressure tip, same as A-301 with 12" insertion depth
A-301-SS	SS static pressure tip, for 1/4" metal tubing connection
A-302	Static pressure tip, for 3/16" and 1/8" ID plastic or rubber tubing
A-302-A	Static pressure tip, same as A-302 with 6" insertion depth
A-303	Portable static pressure tip, for 3/16" ID rubber or plastic tubing with 4" insertion
A-305 low resistance static pressure tip is designed for use in dust-laden air and for rapid response applications. It is recommended where a very low actuation pressure is required for a pressure switch or indicating gage — or where response time is critical.	
A-305	Static pressure tip, low resistance application, furnished with two (2) hex jam nuts and two (2) mounting washers for duct mounting and with 1/8" NPT pipe thread for pressure connection
A-305-SS	SS static pressure tip, low resistance application, furnished with two (2) hex jam nuts and two (2) mounting washers for duct mounting and with 1/8" NPT pipe thread for pressure connection
A-306	Outdoor static pressure sensor. Provides average outdoor pressure signal for reference in building pressurization applications. Includes sensor, 50' vinyl tubing, mounting bracket and hardware. Red sensor
A-306-A	Outdoor static pressure sensor. Provides average outdoor pressure signal for reference in building pressurization applications. Includes sensor, 50' vinyl tubing, mounting bracket and hardware. Gray sensor

USA: California Proposition 65

⚠WARNING: Cancer and Reproductive Harm - www.P65Warnings.ca.gov

ACCESSORIES - KITS FOR AIR FILTER SWITCHES



MODEL CHART	
Model	Description
A-602	Air filter kit, accessory package for using switch without a gage includes two pressure tips with integral compression fittings, two 5' lengths of 1/4" aluminum tubing and two 1/8" NPT to 1/4" tubing compression fittings
A-603	"T" kit, accessory package for using pressure switch in conjunction with an air filter kit equipped Magnehelic® or Series 250 AF gages includes two 1/8" NPT to 1/4" tubing compression fittings and two compression tees
A-604	"T" kit, accessory package for using pressure switch in conjunction with Mark II gages, includes two plastic tubing connector tees and two plastic tubing to 1/8" NPT adapters

USA: California Proposition 65

⚠WARNING: Cancer and Reproductive Harm - www.P65Warnings.ca.gov



STATIC PRESSURE ACCESSORIES

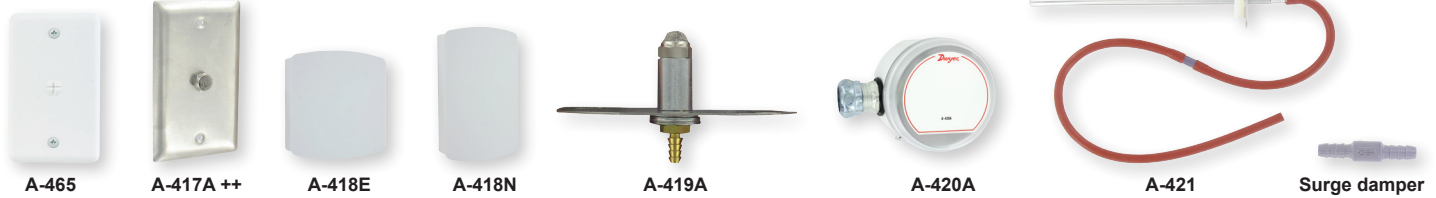

MODEL CHART	
Model	Description
A-465	Static pressure pick-up provides a clean solution for sensing space pressure. The sensor can be mounted on sheetrock walls, single gang electrical boxes, or on ceiling tiles. Molded from ABS plastic, the A-465 provides an integral barb fitting and includes tubing, mounting screws and anchors.
A-417A	Static pressure pickup. For use in clean rooms, 60 micron filter picks up static pressure. Stainless steel wall plate fits 2" x 4" electrical box. Sealed with foam gasket, screws included. Barbed brass fitting holds 1/8" to 3/16" ID tubing.
A-418E	Static pressure pickup. Room mount with plastic enclosure fits 2" x 4" electrical box. Fine mesh screen hides static pressure pickup port. Clean connection to 1/8" to 3/16" ID tubing and pressure sensor. Sealed with foam gasket, screws included.
A-418N	Static pressure pickup. Room mount with plastic enclosure fits 2" x 4" electrical box. Fine mesh screen hides static pressure pickup port. Clean connection to 1/8" to 3/16" ID tubing and pressure sensor. Sealed with foam gasket, screws included.
A-419A	Static pressure pickup ceiling mount. Plate rests on top of standard 3/4" thick ceiling tile while 60 micron filter faces down through 5/8" hole in tile. Filter is barely noticeable in room being monitored. Unit mounts to junction box. Barbed brass fitting holds 1/8" to 3/16" ID tubing.
A-420A	Static pressure pickup for roof or outside mount. Reduces effects of wind gusts to keep pressure readings stable when plate is parallel to ground. Structure withstands harsh environmental elements. Structure is 3-1/4" across and 2-3/8" deep. EMT Conduit fitting is 1/2". Pressure connection is brass barbed fitting for 1/8" and 3/16" ID tubing.
A-421	Static pressure tip measures duct static air pressure. Assembly includes 6" probe, silicon rubber hose, and screws. Built-in surge damper ensures stable readings on pressure sensor. Pressure spike reducer can be added to end of tube to further smooth over pressure fluctuations.

++USA: California Proposition 65

⚠ WARNING: Cancer and Reproductive Harm - www.P65Warnings.ca.gov

GAGE TUBING ACCESSORIES

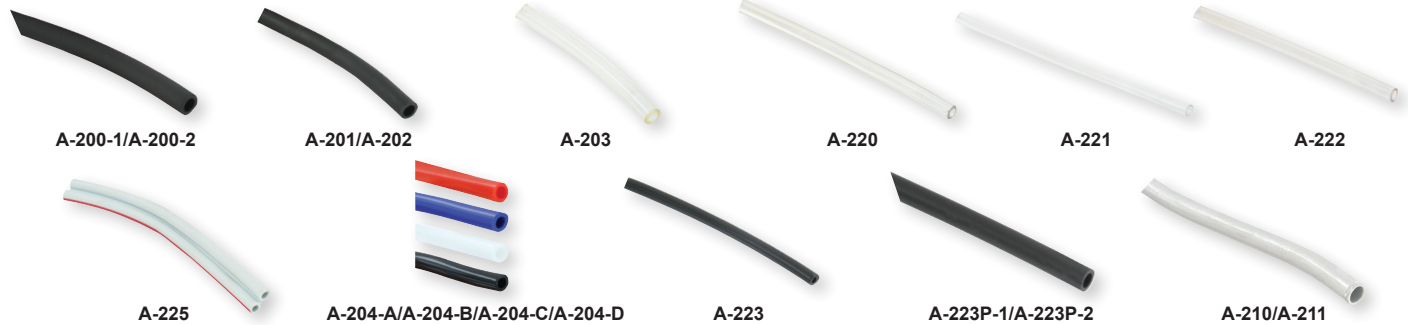

MODEL CHART	
Model	Description
Norprene® tubing is useful in a wide range of temperatures from -75 to 275°F (-60 to 135°C) and will not weaken after long term exposure to heat and ozone.	
A-200-1	3/16" ID x 5/16" OD, 13 psi maximum pressure @ 73°F (90 kPa @ 23°C); 50'
A-200-2	1/4" ID x 3/8" OD, 10 psi maximum pressure @ 73°F (69 kPa @ 23°C); 50'
Rubber latex tubing has less tendency to kink in storage and occupies less space, thus is best for portable work.	
A-201	3/16" ID, 9' length
A-202	3/16" ID, lengths to 50'
Clear PVC tubing is easily inspected and is therefore best for test applications where a possibility of fluid entering the tubing exists.	
A-203	1/8" ID x 1/4" OD, lengths to 100'; 60 psi max. pressure @ 73°F (22°C)
Clear flexible vinyl tubing is easily inspected, and is therefore best for test applications where a possibility of fluid entering the tubing exists.	
A-220	3/16" ID x 5/16" OD, lengths to 500'; 45 psi maximum pressure @ 73°F (310 kPa @ 23°C)
A-221	1/8" ID x 3/16" OD, lengths to 500'; 40 psi maximum pressure @ 165°F (276 kPa @ 74°C)
A-222	.240" ID x .375" OD, lengths to 500'; 35 psi maximum pressure @ 73°F (240 kPa @ 23°C)
Flexible double column plastic tubing is used with Mark II manometers and the Wind Speed Indicator. Light gray with red color code stripe.	
A-225	1/8" ID, lengths to 750'
Flexible colored vinyl tubing is quickly distinguishable in applications where more than one line is required aiding installation.	
A-204-B	3/16" ID x 5/16" OD, lengths to 500'; 45 psi maximum pressure @ 165°F (310 kPa @ 74°C); Opaque blue
A-204-C	3/16" ID x 5/16" OD, lengths to 500'; 45 psi maximum pressure @ 165°F (310 kPa @ 74°C); Opaque white
A-204-D	3/16" ID x 5/16" OD, lengths to 500'; 45 psi maximum pressure @ 165°F (310 kPa @ 74°C); Opaque black
Black polyethylene tubing offers long life, great stability and resistance to corrosion.	
A-223	1/8" ID x 1/4" OD, 10' length; 200 psi maximum @ 140°F (1379 kPa @ 60°C)
Black nylon tubing is recommended for high temperature and pressure applications. -40 to 248°F (-40 to 120°C).	
Black plenum fire retardant polyethylene tubing meets NFPA standard 90A for installation in air-conditioning and ventilating plenum spaces; also used in building automation systems. Lengths to 500', 100 psig maximum pressure @ 75°F (689 kPa @ 24°C).	
A-223P-1	.17" ID x .25" OD
A-223P-2	1/4" ID x 3/8" OD
Aluminum tubing is recommended for permanent installations.	
A-210	1/4" OD, 5' length, 500 psi maximum pressure @ 200°F (3447 kPa @ 93°C)
A-211	1/4" OD, 50' length, 500 psi maximum pressure @ 200°F (3447 kPa @ 93°C)

Norprene® is a registered trademark of Saint-Gobain Abrasives, Inc. Corporation

PRESSURE CONVERSION CHART

in/H ₂ O	P.S.I.	in/Hg	mm/H ₂ O	mm/Hg	kg/cm ²	bar	mbar	Pa	kPa
.1	.0036	.0073	2.534	.1863	.0002	.0002	.2482	24.82	.0248
.2	.0072	.0146	5.067	.3726	.0005	.0005	.4964	49.64	.0496
.4	.0144	.0293	10.13	.7452	.0010	.0010	.9928	99.28	.0993
.6	.0216	.0440	15.20	1.118	.0015	.0015	1.489	148.9	.1489
.8	.0288	.0588	20.34	1.496	.0020	.0020	1.992	199.2	.1992
1.0	.0361	.0735	25.41	1.868	.0025	.0025	2.489	248.9	.2489
2	.0722	.1470	50.81	3.736	.0051	.0050	4.978	497.8	.4978
3	.1083	.2205	76.22	5.604	.0076	.0075	7.467	746.7	.7476
4	.1444	.2940	101.62	7.472	.0102	.0099	9.956	995.6	.9956
5	.1804	.3673	127.0	9.335	.0127	.0124	12.44	1244	1.244
6	.2165	.4408	152.4	11.203	.0152	.0149	14.93	1493	1.493
7	.2526	.5143	177.8	13.072	.0178	.0174	17.42	1742	1.742
8	.2887	.5878	203.2	14.940	.0203	.0199	19.90	1990	1.990
9	.3248	.6613	228.6	16.808	.0228	.0224	22.39	2239	2.239
10	.3609	.7348	254.0	18.676	.0254	.0249	24.88	2488	2.488
11	.3970	.8083	279.4	20.544	.0279	.0274	27.37	2737	2.737
12	.4331	.8818	304.8	22.412	.0304	.0299	29.86	2986	2.986
13	.4692	.9553	330.2	24.280	.0330	.0324	32.35	3235	3.235
14	.5053	1.029	355.6	26.148	.0355	.0348	34.84	3484	3.484
15	.5414	1.102	381.0	28.016	.0381	.0373	37.33	3733	3.733
16	.5774	1.176	406.4	29.879	.0406	.0398	39.81	3981	3.981
17	.6136	1.249	431.8	31.752	.0431	.0423	42.31	4231	4.231
18	.6496	1.322	457.2	33.616	.0457	.0448	44.79	4479	4.479
19	.6857	1.396	482.6	35.484	.0482	.0473	47.28	4728	4.728
20	.7218	1.470	508.0	37.352	.0507	.0498	49.77	4977	4.977
21	.7579	1.543	533.4	39.22	.0533	.0523	52.26	5226	5.226
22	.7940	1.616	558.8	41.09	.0558	.0547	54.74	5474	5.474
23	.8301	1.690	584.2	42.96	.0584	.0572	57.23	5723	5.723
24	.8662	1.764	609.6	44.82	.0609	.0597	59.72	5972	5.972
25	.9023	1.837	635.0	46.69	.0634	.0622	62.21	6221	6.221
26	.9384	1.910	660.4	48.56	.0660	.0647	64.70	6470	6.470
27	.9745	1.984	685.8	50.43	.0685	.0672	67.19	6719	6.719
28	1.010	2.058	711.2	52.26	.0710	.0696	69.64	6964	6.964
29	1.047	2.132	736.6	54.18	.0736	.0722	72.19	7219	7.219
30	1.083	2.205	762.0	56.04	.0761	.0747	74.67	7467	7.467
31	1.119	2.278	787.5	57.91	.0787	.0772	77.15	7715	7.715
32	1.155	2.352	812.8	59.77	.0812	.0796	79.63	7963	7.963
33	1.191	2.425	838.2	61.63	.0837	.0821	82.12	8212	8.212
34	1.227	2.498	863.5	63.49	.0862	.0846	84.60	8460	8.460
35	1.263	2.571	888.9	65.36	.0888	.0871	87.08	8708	8.708
36	1.299	2.645	914.2	67.22	.0913	.0896	89.56	8956	8.956
37	1.335	2.718	939.5	69.08	.0938	.0920	92.04	9204	9.204
38	1.371	2.791	964.9	70.95	.0964	.0945	94.53	9453	9.453
39	1.408	2.864	990.2	72.86	.0990	.0971	97.08	9708	9.708
40	1.444	2.940	1016	74.72	.1015	.0996	99.56	9956	9.956
41	1.480	3.013	1042	76.59	.1040	.1020	102.04	10204	10.204
42	1.516	3.086	1067	78.45	.1066	.1045	104.52	10452	10.452
43	1.552	3.160	1092	80.31	.1091	.1070	107.00	10700	10.700
44	1.588	3.233	1118	82.18	.1116	.1095	109.50	10950	10.950
45	1.624	3.306	1143	84.04	.1142	.1120	112.00	11200	11.200
46	1.660	3.379	1168	85.90	.1167	.1144	114.45	11445	11.444
47	1.696	3.453	1194	87.76	.1192	.1169	116.90	11690	11.690
48	1.732	3.526	1219	89.63	.1218	.1194	119.40	11940	11.940
49	1.768	3.600	1244	91.49	.1243	.1219	121.90	12190	12.190
50	1.804	3.673	1270	93.35	.1268	.1244	124.40	12440	12.440
51	1.841	3.748	1296	95.27	.1294	.1269	126.90	12690	12.690
52	1.877	3.822	1321	97.13	.1320	.1294	129.40	12940	12.940
53	1.913	3.895	1346	98.99	.1345	.1319	131.90	13190	13.190
54	1.949	3.968	1372	100.88	.1370	.1344	134.40	13440	13.440
55	1.985	4.041	1397	102.7	.1395	.1369	136.90	13690	13.690
56	2.021	4.115	1422	104.6	.1421	.1393	139.30	13930	13.930
57	2.057	4.188	1448	106.4	.1446	.1418	141.80	14180	14.180
58	2.093	4.261	1473	108.3	.1471	.1443	144.30	14430	14.430
59	2.129	4.335	1498	110.2	.1497	.1468	146.80	14679	14.680
60	2.165	4.408	1524	112.0	.1522	.1493	149.30	14927	14.930
61	2.202	4.483	1550	113.9	.1548	.1518	151.80	15182	15.180
62	2.238	4.556	1575	115.8	.1573	.1543	154.30	15430	15.430
63	2.274	4.630	1600	117.7	.1599	.1568	156.80	15679	15.680
64	2.310	4.703	1626	119.5	.1624	.1593	159.30	15927	15.930
65	2.346	4.776	1651	121.4	.1649	.1618	161.80	16175	16.180
66	2.382	4.850	1676	123.3	.1674	.1642	164.20	16423	16.420
67	2.418	4.923	1702	125.1	.1700	.1667	166.70	16672	16.670
68	2.454	4.996	1727	127.0	.1725	.1692	169.20	16920	16.920
69	2.490	5.070	1752	128.8	.1750	.1717	171.70	17168	17.170
70	2.526	5.143	1778	130.7	.1776	.1742	174.20	17416	17.420
71	2.562	5.216	1803	132.6	.1801	.1766	176.60	17664	17.660
72	2.598	5.290	1828	134.4	.1826	.1791	179.10	17912	17.910
73	2.635	5.365	1854	136.4	.1852	.1817	181.70	18168	18.170
74	2.671	5.438	1880	138.2	.1878	.1842	184.20	18416	18.420
75	2.707	5.511	1905	140.1	.1903	.1866	186.60	18664	18.660
76	2.743	5.585	1930	141.9	.1928	.1891	189.10	18912	18.910
77	2.779	5.658	1956	143.8	.1954	.1916	191.60	19160	19.160
78	2.815	5.731	1981	145.7	.1979	.1941	194.10	19409	19.410
79	2.851	5.805	2006	147.5	.2004	.1966	196.60	19657	19.660
80	2.887	5.878	2032	149.4	.2030	.1991	199.10	19905	19.900
81	2.923	5.951	2057	151.2	.2055	.2015	201.50	20153	20.150
82	2.959	6.024	2082	153.1	.2080	.2040	204.00	20402	20.400
83	2.996	6.100	2108	155.0	.2106	.2066	206.60	20657	20.660
84	3.032	6.173	2134	156.9	.2131	.2091	209.10	20905	20.900
85	3.068	6.246	2159	158.8	.2157	.2115	211.50	21153	21.150
86	3.104	6.320	2184	160.6	.2182	.2140	214.00	21401	21.400
87	3.140	6.393	2210	162.5	.2207	.2165	216.50	21650	21.650
88	3.176	6.466	2235	164.4	.2233	.2190	219.00	21898	21.900
89	3.212	6.540	2260	166.2	.2258	.2215	221.50	22146	22.150
90	3.248	6.613	2286	168.1	.2283	.2239	223.90	22394	22.390
91	3.284	6.686	2311	169.9	.2309	.2264	226.40	22642	22.640
92	3.320	6.760	2336	171.8	.2334	.2289	228.90	22890	22.890
93	3.356	6.833	2362	173.7	.2359	.2314	231.40	23139	23.140
94	3.392	6.906	2387	175.5	.2384	.2339	233.90	23387	23.390
95	3.429	6.981	2413	177.4	.2410	.2364	236.40	23642	23.640
96	3.465	7.055	2438	179.3	.2436	.2389	238.90	23890	23.890
97	3.501	7.128	2464	181.2	.2461	.2414	241.40	24138	24.140
98	3.537	7.201	2489	183.0	.2486	.2439	243.90	24387	24.390
99	3.573	7.275	2514	184.9	.2512	.2464	246.40	24635	24.640
100	3.609	7.348	2540	186.8	.2537	.2488	248.80	24883	24.880

P.S.I.	in/H ₂ O	in/Hg	mm/H ₂ O	mm/Hg	kg/cm ²	bar	mbar	Pa	kPa
1.0	27.71	2.036	703.1	51.75	.0703	.0689	68.95	6895	6.895
1.1	30.45	2.240	773.4	56.89	.0773	.0758	75.84	7584	7.584
1.2	33.22	2.443	843.7	62.06	.0844	.0827	82.74	8274	8.274
1.3	35.98	2.647	914.0	67.23	.0914	.0896	89.63	8963	8.963
1.4	38.75	2.850	984.3	72.40	.0984	.0965	96.52	9652	9.652
1.5	41.52	3.054	1055	77.57	.1055	.1034	103.40	10340	10.340
1.6	44.29	3.258	1125	82.74	.1125	.1103	110.30	11030	11.030
1.7	47.06	3.461	1195	87.92	.1195	.1172	117.20	11720	11.720
1.8	49.82	3.665	1266	93.09	.1266	.1241	124.10	12410	12.410
1.9	52.59	3.868	1336	98.26	.1336	.1310	131.00	13100	13.100
2.0	55.36	4.072	1406	103.4	.1406	.1379	137.90	13790	13.790
2.1	58.13	4.276	1476	108.6	.1476	.1448	144.80	14480	14.480
2.2	60.90	4.479	1547	113.8	.1547	.1517	151.70	15170	15.170
2.3	63.67	4.683	1617	118.9	.1617	.1586	158.60	15860	15.860
2.4	66.43	4.886	1687	124.1	.1687	.1655	165.50	16550	16.550
2.5	69.20	5.090	1758						



Dwyer[®]

Manufacturing Excellence
Since 1931



BUILDING AUTOMATION SYSTEMS

Pressure | Temperature | Air Quality | Flow | Level | Process Control

ORDER ONLINE TODAY | dwyer-inst.com