

Sensible Solutions...

Fast!



Burn-in/Test & RF Sockets

For QFPs, TSSOPs, CSPs, BGAs, QFNs, MLFs

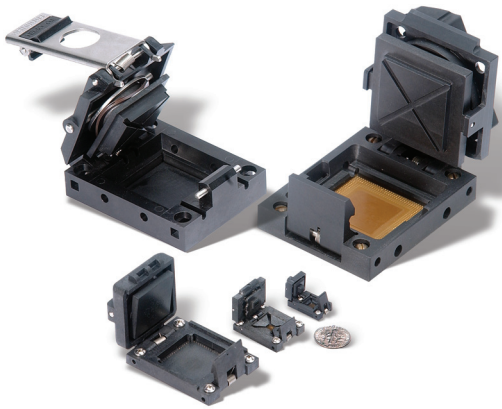

- Unique, patented 2-piece Spring-Probe System
- For ICs on 0.2mm pitch and greater
- Five standard molded sizes for devices up to 55mm²
- Custom machined sockets available for ANY device
- Elastomer contact systems for device testing beyond 45GHz

Correct-A-Chip™ Adapters

For SOICs, SSOPs, TSSPOs, QFNs

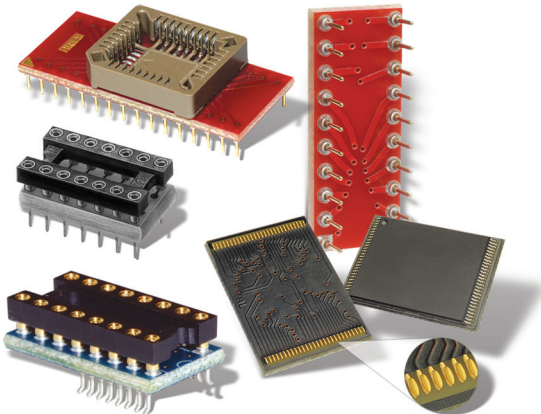

- Converts and/or re-routes any IC device package to any other IC device package
- Eliminates the need to re-spin PCBs for IC end-of-life or IC package change
- SMT or thru-hole designs. RoHS or leaded (Pb) versions available
- Available turnkey operation with new IC assembled onto adapter
- Standard and custom designs can be delivered in 15 work days or less

Vertisockets™

For DIPs, LEDs, DIP Switches, Test Points, Board-to-Board Jumpers

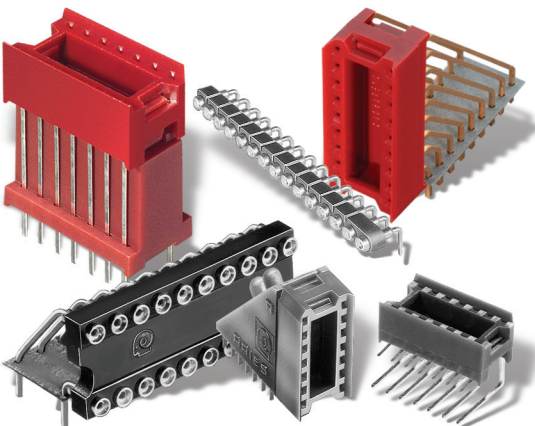

- Horizontal or vertical display
- Various mounting positions and pin configuration
- Exceptional design freedom
- Restricted entry for contact protection
- Elevate devices to desired level from 0.260" to 1.250" height extensions
- Mount components at right angle to printed circuit board

ZIF Sockets

For DIPs, SOICs, PGAs, PLCCs

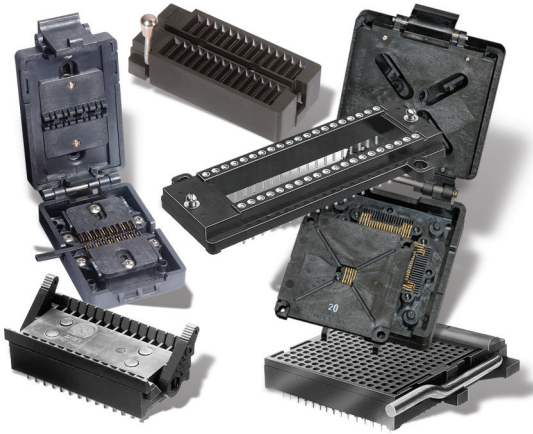

- Variety of row spacings, pin counts and grid footprints
- Contacts normally closed, eliminating dependence on plastic to sustain contact
- Handles configured in either up or down position and mounted on right or left side
- Sockets can be soldered into printed circuit boards or plugged into other sockets or test receptacles
- Custom designs upon request

High-Temperature (200-300°C) ZIF Sockets

For DIPs, PGAs, CSPs, BGAs, LGAs, QFNs, MLCCs, More

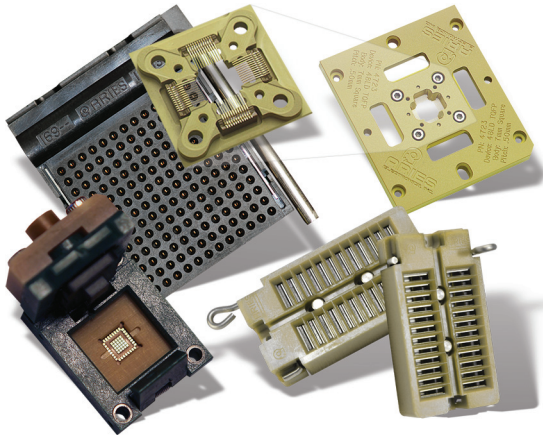

- For burn-in and test applications
- Accepts various row spacings, pin counts and grid footprints on standard 8x8 to 21x21 grids
- High-frequency bandwidth (-1dB at >40GHz), low inductance (0.02nH) and high-current (4 amps at 14°C heat rise) applications
- Enables reliable ATE testing and burn-in

DIP/SIP Sockets & Headers

For DIPs, LCDs, Odd-shaped Devices

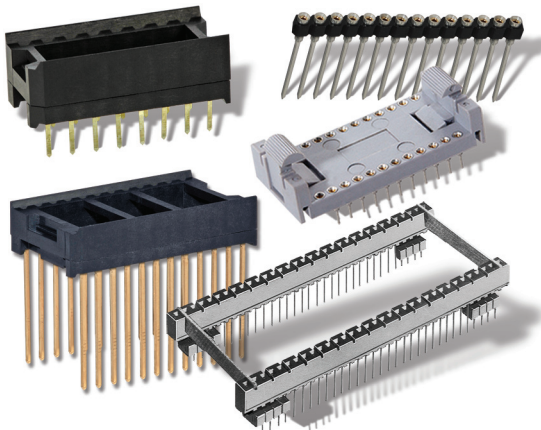

- With solder pin tail, wire wrap, bifurcated, collet contacts
- Single and dual row
- Side-to-side and end-to-end stackable
- Open frame for better air flow
- Compatible with automatic insertion equipment

Cable Assemblies

With DIP and SIP Jumpers

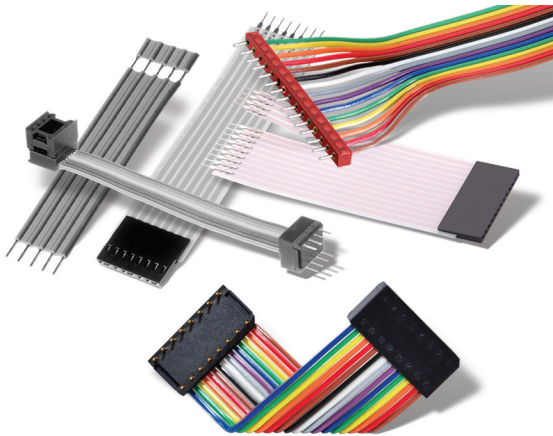

- Flexible, fusion-bonded, color-coded
- Solid Copper conductors embedded between layers of tough, flexible, flame-retardant insulation
- A wide array of DIP jumper configurations and wiring possibilities
- Reliable, electronically tested solder connections

Custom Capabilities

For New or Specialized Components

Aries Electronics specializes in custom design and production. Special materials, platings, sizes, and configurations can be furnished, depending on quantity.

As a leading manufacturer of a broad range of interconnect products, our Correct-A-Chip[®] technology provides universal access with existing packages without redesign.

Some of our expertise lies in...

- Pin Installation into Plastic
- Molding Engineered Plastics with Tight Tolerances
- Crimping Connectors on Flat Cable
- Flat Cable Wire Stripping and Separation
- Custom High-Frequency (RF) Socket Design
- Surface-mounting of Electronic Components
- Bending Pins (Vertisocket[™] Line)
- Patented Limited-depth Pin Assembly for Adapter Flexibility

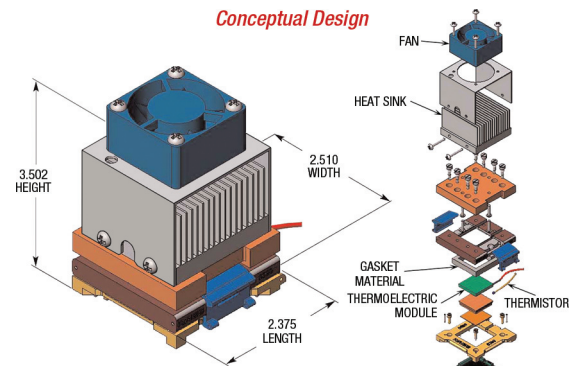

Aries reserves the right to change product general specifications without notice.

Aries Electronics, Inc.

2609 Bartram Road • Bristol, PA 19007-6810 USA

Tel: 215-781-9956 • Fax: 215-781-9845 • Email: info@arieselec.com

www.AriesElec.com