



M28840

Amphenol PCD now offering a complete line of M28840 Circular Connectors according to MIL-DTL-28840.



TABLE OF CONTENTS

Content	Military Slash	Commercial Reference	Pg.
Performance Specification	-	-	5
Insert Arrangement	-	-	6
Straight Strain-Relief Backshell	M28840/1	IN8840/1	7
90° Strain-Relief Backshell	M28840/2	IN8840/2	8
45° - Strain Relief Backshell	M28840/3	IN8840/3	9
Back Shell For Metal Core Conduit	M28840/5	IN8840/5	10
EMI/RFI Environmental Backshell	M28840/6	IN8840/6	12
Dummy Storage Receptacle	M28840/7	IN8840/7	14
90° EMI/RFI Environmental Backshell	M28840/8	IN8840/8	15
45° EMI/RFI Environmental Backshell	M28840/9	IN8840/9	17
Wall Mount Receptacle Connector	M28840/10	IN8840/10	19
In Line Receptacle Connector	M28840/11	IN8840/11	20
Box Mount Receptacle Connector	M28840/12	IN8840/12	21
Protective Receptacle Cover	M28840/13	IN8840/13	22
Jam Nut Receptacle Connector	M28840/14	IN8840/14	23
Protective Plug Cover	M28840/15	IN8840/15	24
Plug Connector	M28840/16	IN8840/16	25
Plug Connector With Straight Strain Relief Backshell	M28840/17	IN8840/17	26
Plug Connector With 90° Strain Relief Backshell	M28840/18	IN8840/18	27
Plug Connector With 45° Strain Relief Backshell	M28840/19	IN8840/19	28
Receptacle Connector With Straight EMI/RFI Backshell	M28840/20	IN8840/20	29
Receptacle Connector With Straight EMI/RFI Backshell	M28840/21	IN8840/21	30
Metal Conduit Bushing	M28840/22	IN8840/22	31
E Nut	M28840/23	IN8840/23	32
Mounting Gasket Metal	M28840/24	IN8840/24	33
90° EMI Conduit Adaptor	M28840/25	IN8840/25	34
Plug Connector With Straight EMI/RFI Backshell	M28840/26	IN8840/26	36
45° EMI Conduit Adaptor	M28840/27	IN8840/27	37
90° Adaptor Assembly Plug	M28840/28	IN8840/28	39
Plug Connector With 45° EMI/RFI Backshell	M28840/29	IN8840/29	40
Metal Conduit Coupler Style A & B	M28840/30	IN8840/30	41
Standard Duty Electrical Pin Contact	M39029/83	IN8840/83	42
Standard Duty Electrical Socket Contact	M39029/84	IN8840/84	43
Polarization Keyways And Panel Cut Out	-	-	44
Contact Insertion / Extraction Instructions	-	-	45
Contact Crimping, Insertion, Removal Tools	-	-	47

M28840 SHIPBOARD CONNECTORS

Overview

Amphenol, a leading manufacturer of connectors now offers complete line of M28840 circular connectors according to MIL-DTL-28840. These shipboard application connectors are precision-machined, highly reliable, and meet superior mechanical shock performances. These high-density connectors are designed and tested to withstand extreme environmental conditions and demanding applications. Amphenol also offers the full range of backshells to support this connector series.

Features

- Precision-machined to MIL-DTL-28840 specification
- Available in nine shell sizes: 11, 13, 15, 17, 19, 23, 25, 29 & 33
- Pin count - 7, 12, 21, 31, 42, 64, 92, 121 and 155
- Plating options – Cadmium, Zinc Nickel & Tin Zinc (Commercial only)
- Support connectors and kits with accessories
- Six keying options (1, 2, 3, 4, 5, 6) for both plugs and receptacles
- Contact size is 20 with wire accommodation options from AWG 20 to AWG 28
- Crimp termination, rear insert and front release contacts
- Complete line of straight, 90° and 45° backshells

Benefits

- Fully intermateable and interchangeable with any qualified M28840 connector
- Backshell designs for strain relief, EMI and environmental sealing
- Options to buy connector kitted with backshell and accessories
- Same application tool for all three types of contacts

Applications

- US Navy shipboard, surface craft and submarines
- Mission critical combat and communications systems
- Mobile tactical shelters electronic battlefield networks
- Mobile emergency telecommunications (MET) stations
- Deployable outdoors in harsh environments



MIL-DTL-28840 SHIPBOARD ELECTRICAL CONNECTORS

Performance Specifications

Performance Specifications	
Current Rating	Size # 20 contact 20AWG 7.5A, 22AWG 5.0A, 28AWG 1.5A, 30AWG 1.0A
Test Voltage	1000 VAC RMS at sea level, test in accordance with EIA-364-20
Insulation Resistance	5000 megohms min. (at ambient temp) per EIA-364-21
Contact Resistance	Per SAE-AS39029
Operating Temperature	-55° C to +200°C
Fluid Immersion	Test method EIA-364-10
Shock	In accordance with MIL-S-901 grade A
Vibration	In accordance with EIA-364-28
Magnetic Permeability	less than 2.0 μ (Aluminum) ASTM-A342/A342M

Materials & Finishes

Materials & Finishes	
Shells, Coupling Nuts, Jam Nuts	Aluminum Alloy per ASTM B211, or Stainless Steel per AMS-QQ-S-763
Contacts	Copper Alloy, 50 microinches Gold plated per ASTM B488 Type 3, Code C Class 1 over nickel underplate per QQ-N-290 Class 2 Socket contact hood: Stainless Steel passivated
Insulators	High Grade Engineering Plastic
Contact Retention Clip	Beryllium Copper
Grommet Seal	Blended Elastomer
Plating	Cadmium, Zinc Nickel & Tin Zinc (Commercial only)

Contact Code	Type	Contact Specification	Contact Size	Acceptable Wire Size	Outside Ø of Finished Wire	
					Min.	Max.
F	Pin	M39029/83-508	20-20	24	1.02 (.040)	1.02 (.040)
G	Socket	MS39029/84-509		22		
P	Pin	MS39029/83-450	20-22	20		
S	Socket	MS39029/84-452		26		
D	Pin	MS39029/83-451	20-28	24		
E	Socket	MS39029/84-453		22		

M28840 SHIPBOARD CONNECTORS

Shell Size & Contacts



Shell Size 11
7 Contacts

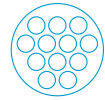

Shell Size 13
12 Contacts

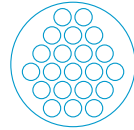

Shell Size 15
21 Contacts

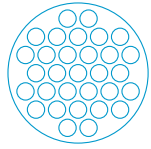

Shell Size 17
31 Contacts

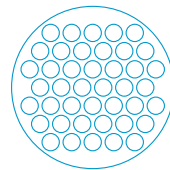

Shell Size 19
42 Contacts

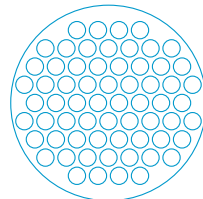

Shell Size 23
64 Contacts

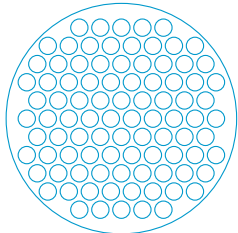

Shell Size 25
92 Contacts

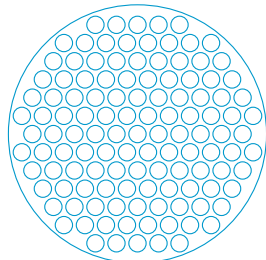

Shell Size 29
121 Contacts

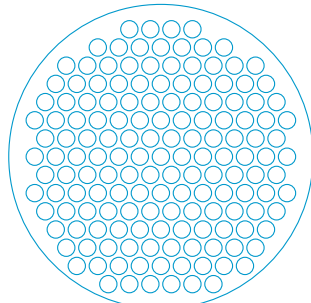

Shell Size 33
155 Contacts

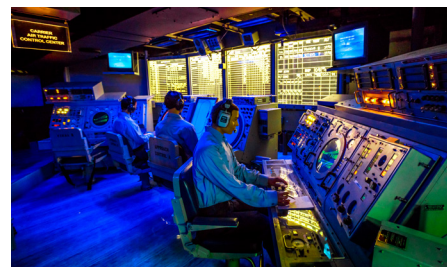

M28840/1 STRAIGHT STRAIN RELIEF BACKSHELL

M28840/1	J	W
DESIGNATION	SHELL SIZE	MATERIAL & FINISH
QPL: M28840/1 Commercial: IN28840/1	A: 11 B: 13 C: 15 D: 17 E: 19 F: 23 G: 25 H: 29 J: 33	W: Aluminum, Cadmium Plate, O.D. over Electroless Nickel S: Aluminum -Zinc Nickel, Non-Reflective L: Aluminum-Tin-Zinc, Non-Reflective (Commercial only)

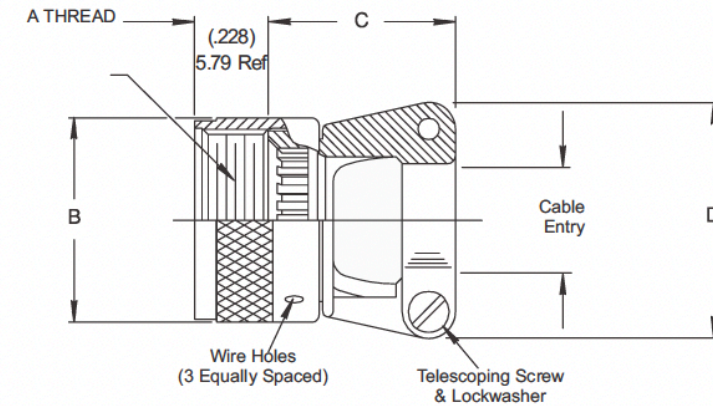

Military Shell Size	Shell Size	A Thread Class 2B	B Ø Max.	C Max.	D Max.	Screw Size Ref.	A Cable Entry	
							Min.	Max.
A	11	.750-20 UNEF	(1.028) 26.11	(1.091) 27.71	(.903) 2.94	.114-40	(.177) 4.50	(.286) 7.26
B	13	.875-20 UNEF	(1.141) 28.98	(1.091) 27.71	(.977) 24.82	.114-40	(.177) 4.50	(.286) 7.26
C	15	1.000-20 UNEF	(1.263) 32.08	(1.091) 27.71	(1.151) 29.24	.114-40	(.250) 6.35	(.416) 10.57
D	17	1.125-18 UNEF	(1.387) 35.23	(1.206) 30.63	(1.281) 32.54	.114-40	(.291) 7.39	(.476) 12.09
E	19	1.250-18 UNEF	(1.513) 38.43	(1.320) 33.53	(1.406) 35.71	.114-40	(.348) 8.84	(.626) 15.90
F	23	1.438-18 UNEF	(1.703) 43.26	(1.445) 36.70	(1.576) 40.03	.134-32	(.429) 10.90	(.831) 21.11
G	25	1.562-18 UNEF	(1.825) 46.36	(1.570) 39.88	(1.666) 42.32	.134-32	(.523) 13.28	(.956) 24.28
H	29	1.875-16 UN	(2.143) 54.43	(1.721) 43.71	(2.046) 51.97	.134-32	(.643) 16.33	(1.081) 27.46
J	33	2.062-16 UNS	(2.329) 59.16	(1.908) 48.46	(2.209) 56.11	.162-32	(.704) 17.88	(1.187) 30.15



www.powell.com
800-235-7880
pcdinfo@powell.com

* Dimensions in (inches) mm

M28840/2 90° STRAIN RELIEF BACKSHELL

M28840/2	J	W
DESIGNATION	SHELL SIZE	MATERIAL & FINISH
QPL: M28840/2 Commercial: IN28840/2	A: 11 B: 13 C: 15 D: 17 E: 19 F: 23 G: 25 H: 29 J: 33	W: Aluminum, Cadmium Plate, O.D. over Electroless Nickel S: Aluminum -Zinc Nickel, Non-Reflective L: Aluminum-Tin-Zinc, Non-Reflective (Commercial only)

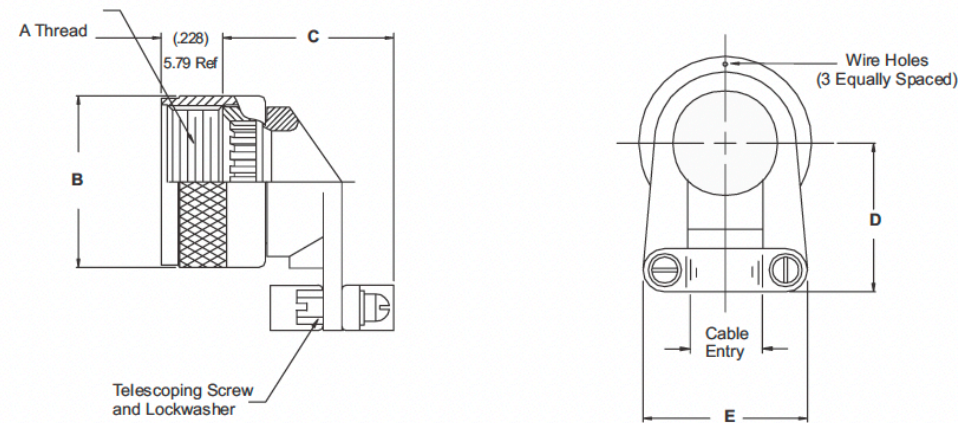

Military Shell Size	Shell Size	A Thread Class 2B	B Ø Max.	C Max.	D Max.	E Max.	Screw Size Ref.	Cable Entry	
								Min.	Max.
A	11	.750-20 UNEF	(1.028) 26.11	(1.071) 27.20	(.929) 23.60	(.903) 22.94	.114-40	(.177) 4.50	(.286) 7.26
B	13	.875-20 UNEF	(1.141) 28.98	(1.071) 27.20	(.929) 23.60	(.977) 24.82	.114-40	(.177) 4.50	(.286) 7.26
C	15	1.000-20 UNEF	(1.263) 32.08	(1.280) 32.51	(1.056) 26.82	(1.151) 29.24	.114-40	(.250) 6.35	(.416) 10.57
D	17	1.125-18 UNEF	(1.387) 35.23	(1.392) 35.36	(1.233) 31.32	(1.281) 32.54	.114-40	(.291) 7.39	(.476) 12.09
E	19	1.250-18 UNEF	(1.513) 38.43	(1.517) 38.53	(1.296) 32.92	(1.406) 35.71	.114-40	(.348) 8.84	(.626) 15.90
F	23	1.438-18 UNEF	(1.703) 43.26	(1.642) 41.71	(1.358) 34.49	(1.576) 40.03	.134-32	(.429) 10.90	(.831) 21.11
G	25	1.562-18 UNEF	(1.825) 46.36	(1.767) 44.88	(1.420) 36.07	(1.666) 42.32	.134-32	(.523) 13.28	(.956) 24.28
H	29	1.875-16 UN	(2.143) 54.43	(1.905) 48.39	(1.634) 41.50	(2.046) 51.97	.134-32	(.643) 16.33	(1.081) 27.46
J	33	2.062-16 UNS	(2.329) 59.16	(1.968) 49.99	(1.859) 47.22	(2.209) 56.11	.162-32	(.704) 17.88	(1.187) 30.15

M28840/3 45° STRAIN RELIEF BACKSHELLS

M28840/3	J	W
DESIGNATION	SHELL SIZE	MATERIAL & FINISH
QPL: M28840/3 Commercial: IN28840/3	A: 11 B: 13 C: 15 D: 17 E: 19 F: 23 G: 25 H: 29 J: 33	W: Aluminum, Cadmium Plate, O.D. over Electroless Nickel S: Aluminum -Zinc Nickel, Non-Reflective L: Aluminum-Tin-Zinc, Non-Reflective (Commercial only)

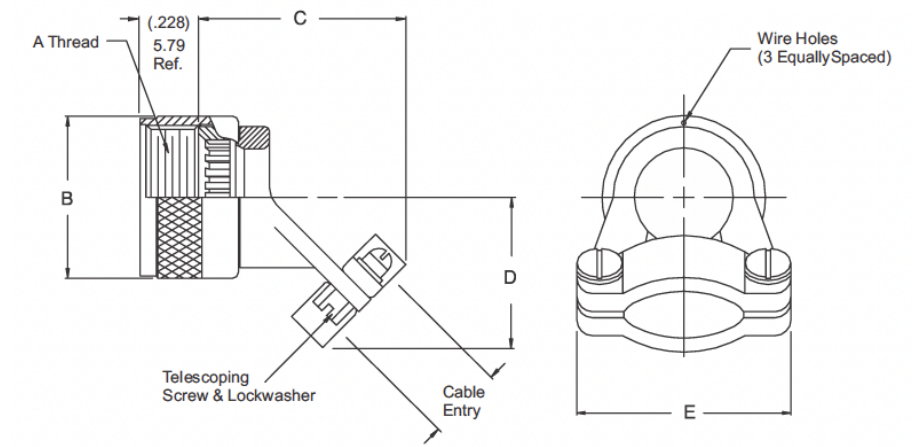

Military Shell Size	Shell Size	A Thread Class 2B	B Ø Max.	C Max.	D Max.	E Max.	Screw Size Ref.	Cable Entry	
								Min.	Max.
A	11	.750-20 UNEF	(1.028) 26.11	(1.091) 27.71	(.929) 23.60	(.903) 22.94	.114-40	(.177) 4.50	(.286) 7.26
B	13	.875-20 UNEF	(1.141) 28.98	(1.091) 27.71	(.929) 23.60	(.977) 24.82	.114-40	(.177) 4.50	(.286) 7.26
C	15	1.000-20 UNEF	(1.263) 32.08	(1.091) 27.71	(1.056) 26.82	(1.151) 29.24	.114-40	(.250) 6.35	(.416) 10.57
D	17	1.125-18 UNEF	(1.387) 35.23	(1.206) 30.63	(1.233) 31.32	(1.281) 32.54	.114-40	(.291) 7.39	(.476) 12.09
E	19	1.250-18 UNEF	(1.513) 38.43	(1.320) 33.53	(1.296) 32.92	(1.406) 35.71	.114-40	(.348) 8.84	(.626) 15.90
F	23	1.438-18 UNEF	(1.703) 43.26	(1.445) 36.70	(1.358) 34.49	(1.576) 40.03	.134-32	(.429) 10.90	(.831) 21.11
G	25	1.562-18 UNEF	(1.825) 46.36	(1.570) 39.88	(1.420) 36.07	(1.666) 42.32	.134-32	(.523) 13.28	(.956) 24.28
H	29	1.875-16 UN	(2.143) 54.43	(1.721) 43.71	(1.634) 41.50	(2.046) 51.97	.134-32	(.643) 16.33	(1.081) 27.46
J	33	2.062-16 UNS	(2.329) 59.16	(1.908) 48.46	(1.859) 47.22	(2.209) 56.11	.162-32	(.704) 17.88	(1.187) 30.15

M28840/5 BACKSHELL FOR METAL CORE CONDUIT

M28840/5	16	W	A
DESIGNATION	DASH #	MATERIAL & FINISH	BACKSHELL STYLE
QPL: M28840/5 Commercial: IN28840/5	See Table A	W: Aluminum, Cadmium Plate, O.D. over Electroless Nickel S: Aluminum -Zinc Nickel, Non-Reflective L: Aluminum-Tin-Zinc, Non-Reflective (Commercial only)	A: EMI, Non-Environmental B: EMI, Environmental

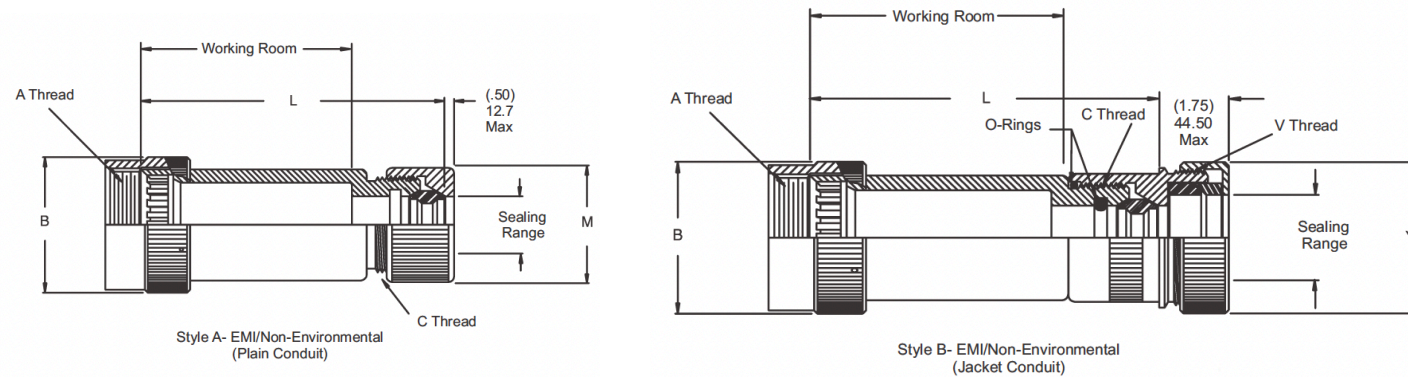

M28840/5 BACKSHELL FOR METAL CORE CONDUIT

DASH #	Military Shell Size	Shell Size	A Thread Class 2B	B Ø Max.	C Thread Class 2	Sealing Range	
						Max.	Min.
01	A	11	.750-20 UNEF	(1.028) 26.11	.875-20 UNEF	(.63) 16.0	(0.50) 12.7
02	B	13	.875-20 UNEF	(1.141) 28.98			
03	B	13	1.000-20 UNEF	(1.263) 32.08	1.000-20 UNEF	(.75) 19.1	(.63) 16.0
04	C	15			.875-20 UNEF	(.63) 16.0	(.50) 12.7
05	C	15	1.250-18 UNEF	(1.387) 35.23	1.000-20 UNEF	(.75) 19.1	(.63) 16.0
06	C	15			1.125-18 UNEF	(.88) 22.4	(.75) 19.1
07	C	15	1.250-18 UNEF	(1.513) 38.43	1.250-18 UNEF	(1.00) 25.4	(.88) 22.4
08	D	17			1.250-18 UNEF	(.88) 22.4	(.75) 19.1
09	D	17	1.438-18 UNEF	(1.703) 45.51	1.250-18 UNEF	(1.00) 25.4	(.88) 22.4
10	D	17			1.625-18 UNEF	(1.38) 35.1	(1.19) 30.2
11	E	19	1.562-18 UNEF	(1.825) 46.35	1.125-18 UNEF	(.88) 22.4	(.75) 19.1
12	E	19			1.250-18 UNEF	(1.00) 25.4	(.88) 22.4
13	E	19	1.875-18 UNS	(2.143) 54.43	1.625-18 UNEF	(1.38) 35.1	(1.19) 30.2
14	F	23			1.250-18 UNEF	(1.00) 25.4	(.88) 22.4
15	F	23	2.062-16 UNS	(2.329) 59.16	1.625-18 UNEF	(1.38) 35.1	(1.19) 30.2
16	F	23			1.875-18 UNS	(1.63) 41.4	(1.44) 36.6
17	G	25	2.750-16 UN	(3.06) 77.8	1.250-18 UNEF	(1.00) 25.4	(.88) 22.4
18	G	25			1.625-18 UNEF	(1.38) 35.1	(1.19) 30.2
19	G	25	1.875-18 UNS	(2.143) 54.43	1.875-18 UNS	(1.63) 41.4	(1.44) 36.6
20	G	25			2.125-16 UN	(1.88) 47.8	(1.63) 41.4
21	H	29	1.875-16 UN	(2.143) 54.43	1.875-18 UNS	(1.63) 41.4	(1.44) 36.6
22	H	29			2.125-16 UN	(1.88) 47.8	(1.63) 41.4
23	J	33	2.062-16 UNS	(2.329) 59.16	2.125-16 UN	(1.88) 47.8	(1.63) 41.4
24	J	33			2.750-16 UN	(2.38) 60.5	(2.13) 54.1
25	A	11	.750-20 UNEF	(1.028) 26.11	.875-20 UN	(.75) 19.05	(.63) 16.00

DASH #	Military Shell Size	Shell Size	Conduit Size	L ± .12 (3.05)	Working Room Ref.	V Thread Class 2	M Ø Max.	Y Ø Max.
01	A	11	03	(1.75) 44.45	(1.00) 25.4	1.00-20 UNEF	(1.12) 28.45	1.19 (30.23)
02	B	13				1.188-18 UNEF	(1.25) 31.8	(1.38) 35.1
03	B	13	04			1.000-20 UNEF	(1.12) 28.5	(1.19) 30.23
04	C	15	03			1.188-30 UNEF	(1.25) 31.8	(1.38) 35.1
05	C	15	04	(3.00) 76.2	(1.50) 38.10	1.438-18 UNEF	(1.43) 36.3	(1.63) 41.4
06	C	15	05			1.750-18 UNS	(1.62) 41.2	(1.94) 49.3
07	C	15	06	(2.25) 57.15	(2.00) 50.80	1.438-18 UNEF	(1.43) 36.3	(1.63) 41.4
08	D	17	05			1.750-18 UNS	(1.62) 41.2	(1.94) 49.3
09	D	17	06			2.00-18 UNS	(1.81) 46.0	(2.19) 55.6
10	D	17	08			1.438-18 UNEF	(1.43) 36.3	(1.63) 41.4
11	E	19	05	(2.75) 69.85	(2.00) 50.80	1.750-18 UNEF	(1.62) 41.2	(1.94) 49.3
12	E	19	06			1.750-18 UNEF	(1.62) 41.2	(1.94) 49.3
13	E	19	08	(2.75) 60.85	(2.00) 50.80	2.00-18 UNS	(1.81) 46.0	(2.19) 55.6
14	F	23	06			1.750-18 UNS	(1.62) 41.2	(1.94) 49.3
15	F	23	08	(3.50) 88.90	(2.00) 50.80	2.00-18 UN	(1.81) 46.0	(2.19) 55.6
16	F	23	10			2.00-16 UN	(2.18) 55.4	(2.44) 62.0
17	G	25	06	(2.75) 60.85	(2.00) 50.80	1.750-18 UN	(1.62) 41.2	(1.94) 49.3
18	G	25	08			2.00-18 UN	(1.81) 46.0	(2.19) 55.6
19	G	25	10	(4.00) 101.6	(2.50) 63.50	2.250-16 UN	(2.18) 55.4	(2.44) 62.0
20	G	25	12			2.500-16 UN	(2.56) 65.0	(2.69) 68.3
21	H	29	10	(3.25) 82.55	(2.50) 63.50	2.250-16 UN	(2.18) 55.4	(2.44) 62.0
22	H	29	12			2.500-16 UN	(2.56) 65.0	(2.66) 68.3
23	J	33	12	(1.75) 44.45	(1.00) 25.4	2.500-16 UN	(2.56) 65.0	(2.60) 88.3
24	J	33	16			3.00-16 UN	(3.06) 77.8	(3.18) 81.0
25	A	11	04	(1.75) 44.45	(1.00) 25.4	1.188-18 UNEF	(1.75) 31.75	(1.38) 35.0

* Dimensions in (inches) mm

* Dimensions in (inches) mm



M28840/6 EMI/RFI ENVIRONMENTAL BACKSHELL

M28840/6	16	W	A
DESIGNATION	DASH #	MATERIAL & FINISH	BACKSHELL STYLE
QPL: M28840/6 Commercial: IN28840/6	See Table A	W: Aluminum, Cadmium Plate, O.D. over Electroless Nickel S: Aluminum -Zinc Nickel, Non-Reflective L: Aluminum-Tin-Zinc, Non-Reflective (Commercial only)	A: EMI, Non-Environmental B: EMI, Environmental

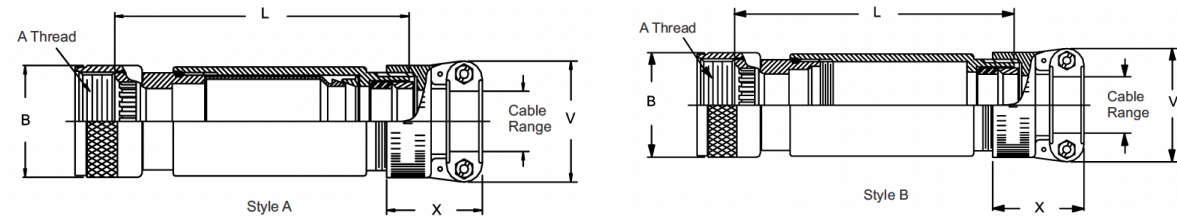

TABLE A								
DASH #	Military Shell Size	Shell Size	A Thread Class 2B	B Ø Max.	C Ø Max.	D Ø Min.	Cable Entry	
							Max.	Min.
01	A	11	.750-20 UNEF	(1.028) 26.11	(1.156) 29.36	(.750) 19.05	(.312) 7.92	(.188) 4.77
02	B	13	.875-20 UNEF	(1.141) 28.98	(1.156) 29.36	(.750) 19.05	(.312) 7.92	(.188) 4.77
03	B	13	.875-20 UNEF	(1.141) 28.98	(1.156) 29.36	(.750) 19.05	(.438) 11.12	(.281) 7.14
04	C	15	1.000-20 UNEF	(1.263) 32.08	(1.281) 32.54	(.875) 22.23	(.312) 7.92	(.188) 4.77
05	C	15	1.000-20 UNEF	(1.263) 32.08	(1.281) 32.54	(.875) 22.23	(.438) 11.12	(.281) 7.14
06	C	15	1.000-20 UNEF	(1.263) 32.08	(1.281) 32.54	(.875) 22.23	(.562) 14.27	(.344) 8.74
07	C	15	1.000-20 UNEF	(1.263) 32.08	(1.406) 35.71	(1.000) 25.40	(.750) 19.05	(.438) 11.12
08	D	17	1.125-18 UNEF	(1.387) 35.23	(1.406) 35.71	(1.000) 25.40	(.625) 15.87	(.375) 9.52
09	D	17	1.125-18 UNEF	(1.387) 35.23	(1.406) 35.71	(1.000) 25.40	(.750) 19.05	(.438) 11.12
10	D	17	1.125-18 UNEF	(1.387) 35.23	(1.531) 38.89	(1.125) 28.58	(.938) 23.82	(.625) 15.87
11	E	19	1.250-18 UNEF	(1.513) 38.43	(1.531) 38.89	(1.125) 28.58	(.625) 15.87	(.375) 9.52
12	E	19	1.250-18 UNEF	(1.513) 38.43	(1.531) 38.89	(1.125) 28.58	(.938) 23.82	(.625) 15.87
13	E	19	1.438-18 UNEF	(1.703) 45.51	(1.656) 42.06	(1.250) 31.75	(.750) 19.05	(.438) 11.12
14	F	23	1.438-18 UNEF	(1.703) 45.51	(1.656) 42.06	(1.250) 31.75	(.938) 23.82	(.625) 15.87
15	F	23	1.438-18 UNEF	(1.703) 45.51	(1.781) 45.24	(1.375) 34.93	(1.188) 30.17	(.812) 20.62
16	F	23	1.562-18 UNEF	(1.825) 46.35	(1.781) 45.24	(1.375) 34.93	(.938) 23.82	(.625) 15.87
17	G	25	1.562-18 UNEF	(1.825) 46.35	(1.781) 45.24	(1.375) 34.93	(1.188) 30.17	(.812) 20.62
18	G	25	1.562-18 UNEF	(1.825) 46.35	(1.781) 45.24	(1.375) 34.93	(1.250) 31.75	(.875) 22.23
19	G	25	1.562-18 UNEF	(1.825) 46.35	(2.156) 54.76	(1.750) 44.45	(1.380) 35.05	(1.000) 25.4
20	G	25	1.875-16 UNS	(2.143) 54.43	(2.156) 54.76	(1.750) 44.45	(1.188) 30.17	(.812) 20.62
21	H	29	1.875-16 UNS	(2.143) 54.43	(2.156) 54.76	(1.750) 44.45	(1.380) 38.05	(1.000) 25.4
22	H	29	2.062-16 UNS	(2.329) 59.16	(2.281) 57.94	(1.875) 47.63	(1.380) 38.05	(1.000) 25.4
23	J	33	2.062-16 UNS	(2.329) 59.16	(2.281) 57.94	(1.875) 47.63	(1.625) 41.28	(1.250) 31.75
24	J	33	.750-20 UNEF	(1.028) 26.11	(1.156) 29.36	(.750) 19.05	(.438) 11.12	(.281) 7.14
25	A	11	.750-20 UNEF	(1.028) 26.11	(1.281) 32.54	(.875) 22.22	(.562) 14.27	(.344) 8.74
26	B	13	.875-30 UNEF	(1.141) 28.98	(1.281) 32.54	(.875) 22.22	(.562) 14.27	(.344) 8.74
27	B	13	.875-30 UNEF	(1.141) 28.98	(1.406) 35.71	(1.000) 25.4	(.625) 15.87	(.375) 9.52
28	C	15	1.000-20 UNEF	(1.263) 32.08	(1.406) 35.71	(1.000) 25.4	(.625) 15.87	(.375) 9.52

* Dimensions in (inches) mm

M28840/6 EMI/RFI ENVIRONMENTAL BACKSHELL

TABLE A							
DASH #	Military Shell Size	Shell Size	L	Working Room Ref.	V Thread Class 2	X Ø Max.	Y Ref.
01	A	11	(3.62) 91.55	(2.00) 50.80	.625-24 UNEF	(1.281) 32.53	(.938) 23.82
02	B	13	(3.62) 91.55	(2.00) 50.80	.625-24 UNEF	(1.281) 32.53	(.938) 23.82
03	B	13	(3.62) 91.55	(2.00) 50.80	.750-20 UNEF	(1.281) 32.53	(1.125) 23.82
04	C	15	(3.62) 91.55	(2.00) 50.80	.625-24 UNEF	(1.281) 32.53	(.938) 23.82
05	C	15	(3.62) 91.55	(2.00) 50.80	.750-20 UNEF	(1.281) 32.53	(1.125) 28.57
06	C	15	(3.62) 91.55	(2.00) 50.80	.875-20 UNEF	(1.281) 32.53	(1.312) 33.32
07	C	15	(4.12) 104.65	(2.50) 63.50	1.188-18 UNEF	(1.312) 33.32	(1.593) 40.62
08	D	17	(4.12) 104.65	(2.50) 63.50	1.000-20 UNEF	(1.281) 32.54	(1.312) 33.32
09	D	17	(4.12) 104.65	(2.50) 63.50	1.188-19 UNEF	(1.312) 33.32	(1.593) 40.62
10	D	17	(4.12) 104.65	(2.50) 63.50	1.438-18 UNEF	(1.406) 35.71	(1.750) 44.45
11	E	19	(4.12) 104.65	(2.50) 63.50	1.000-20 UNEF	(1.281) 32.54	(1.312) 33.32
12	E	19	(4.12) 104.65	(2.50) 63.50	1.438-18 UNEF	(1.406) 35.71	(1.750) 44.45
13	E	19	(4.62) 117.35	(3.00) 76.20	1.188-18 UNEF	(1.312) 33.32	(1.593) 40.62
14	F	23	(4.62) 117.35	(3.00) 76.20	1.438-18 UNEF	(1.406) 35.71	(1.750) 44.45
15	F	23	(4.62) 117.35	(3.00) 76.20	1.750-18 UNS	(1.593) 40.46	(2.093) 53.16
16	F	23	(4.62) 117.35	(3.00) 76.20	1.438-18 UNEF	(1.406) 35.71	(1.750) 44.45
17	G	25	(5.12) 130.05	(3.50) 88.90	1.750-18 UNS	(1.593) 40.46	(2.093) 53.16
18	G	25	(5.12) 130.05	(3.50) 88.90	1.750-18 UNS	(1.593) 40.46	(2.093) 53.16
19	G	25	(5.12) 130.05	(3.50) 88.90	2.000-18 UNS	(1.625) 41.28	(2.343) 59.51
20	G	25	(5.12) 130.05	(3.50) 88.90	1.750-18 UNS	(1.593) 40.46	(2.093) 53.16
21	H	29	(5.12) 130.05	(3.50) 88.90	2.000-18 UNS	(1.625) 41.28	(2.343) 59.51
22	H	29	(5.12) 130.05	(3.50) 88.90	2.000-18 UNS	(1.625) 41.28	(2.343) 59.51
23	J	33	(5.12) 130.05	(3.50) 88.90	2.250-16 UNS	(1.900) 48.26	(2.750) 69.85
24	J	33	(3.62) 91.95	(2.00) 50.80	.750-20 UNEF	(1.281) 32.54	(1.125) 28.57
25	A	11	(3.62) 91.95	(2.00) 50.80	.875-20 UNEF	(1.281) 32.54	(1.312) 33.32
26	B	13	(3.62) 91.95	(2.00) 50.80	.875-20 UNEF	(1.281) 32.54	(1.312) 33.32
27	B	13	(4.12) 104.65	(2.50) 63.50	1.000-20 UNEF	(1.281) 32.54	(1.312) 33.32
28	C	15	(4.12) 104.65	(2.50) 63.50	1.000-20 UNEF	(1.281) 32.54	(1.312) 33.32

* Dimensions in (inches) mm

M28840/7 DUMMY STOWAGE RECEPTACLE

M28840/7	B	4	F
DESIGNATION	SHELL SIZE	KEY POSITION	MATERIAL & FINISH
QPL: M28840/7 Commercial: IN28840/7	A: 11 B: 13 C: 15 D: 17 E: 19 F: 23 G: 25 H: 29 J: 33	1 2 3 4 5 6	No Designation: Aluminum, Cadmium Plate, O.D. over Electroless Nickel S: Aluminum-Zinc Nickel, Non-Reflective L: Aluminum-Tin-Zinc, Non-Reflective (Commercial only)

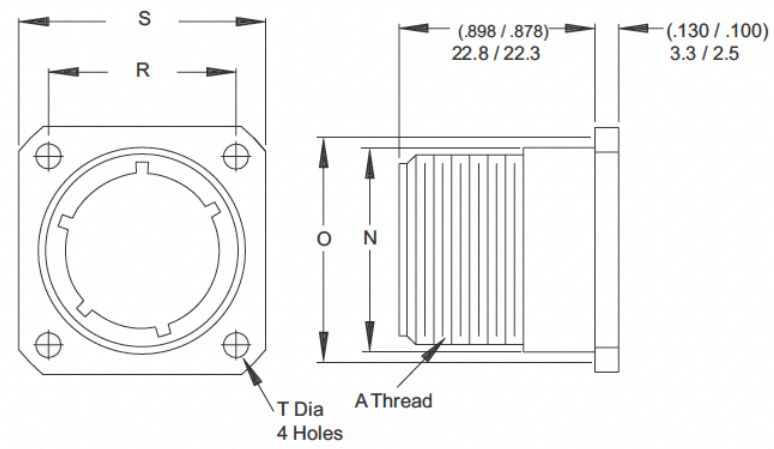

Military Shell Size	Shell Size	N Ø Max.	O Ref. Mating Hole	R True Position ϕ to ϕ	S	T
A	11	(.750) 19.05	(.812) 20.62	(.750) 19.05	(1.043) 26.49 (1.003) 25.48	(1.130) 3.30 (.115) 2.92
B	13	(.875) 22.22	(.937) 23.80	(.843) 21.41	(1.158) 29.41 (1.118) 28.40	
C	15	(1.062) 26.97	(1.124) 28.55	(.968) 24.59	(1.278) 32.46 (1.238) 31.45	
D	17	(1.125) 28.58	(1.187) 30.15	(1.015) 25.78	(1.403) 35.64 (1.363) 34.62	
E	19	(1.312) 33.32	(1.374) 34.90	(1.140) 28.96	(1.528) 38.81 (1.488) 37.80	(1.157) 3.99 (.142) 3.61
F	23	(1.500) 38.10	(1.562) 39.67	(1.281) 32.54	(1.738) 44.15 (1.698) 43.13	
G	25	(1.625) 41.28	(1.687) 42.85	(1.392) 35.36	(1.838) 46.69 (1.798) 45.67	(1.183) 4.65 (.168) 4.27
H	29	(1.812) 46.02	(1.874) 47.60	(1.568) 39.83	(2.158) 54.81 (2.118) 53.80	
J	33	(2.000) 50.80	(2.062) 52.37	(1.734) 44.04	(2.348) 59.64 (2.308) 58.62	

M28840/8 90° EMI/RFI ENVIRONMENTAL BACKSHELL

M28840/8	16	W	A
DESIGNATION	DASH #	MATERIAL & FINISH	BACKSHELL STYLE
QPL: M28840/8 Commercial: IN28840/8	See Table A	W: Aluminum, Cadmium Plate, O.D. over Electroless Nickel S: Aluminum-Zinc Nickel, Non-Reflective L: Aluminum-Tin-Zinc, Non-Reflective (Commercial only)	A: EMI Environmental B: Environmental

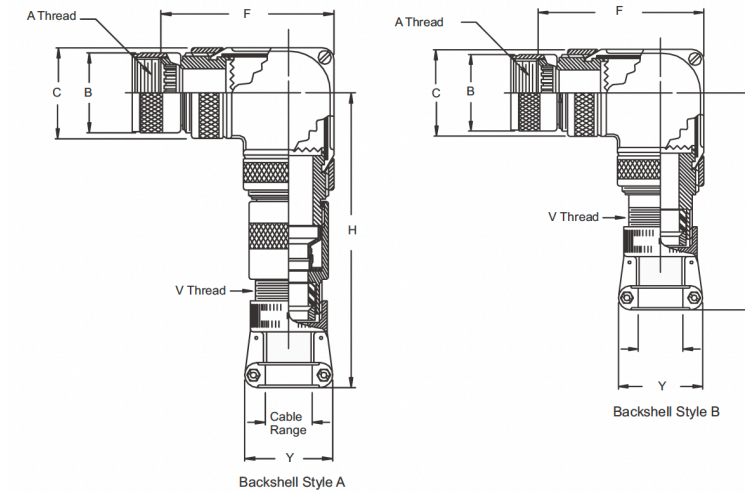

Backshell Shell Size	DASH #	Military Shell Size	Shell Size	A Thread Class 2B	B Ø Max.	C Ø Max.	D Ø Max.		
A	01	A	11	.750-20 UNEF	(1.028) 26.11	(1.188) 30.17	(1.031) 26.19		
A	02	B	13	.875-20 UNEF	(1.141) 28.98				
B	03	B	13						
A	04	C	15	1.00-20 UNEF	(1.263) 32.08	(1.438) 36.52	(1.156) 29.36		
B	05	C	15						
C	06	C	15						
D	07	C	15						
A	08	D	17	1.125-18 UNEF	(1.387) 35.23	(1.688) 42.87	(1.281) 32.54		
B	09	D	17						
C	10	D	17						
A	11	E	19	1.250-18 UNEF	(1.513) 38.43	(1.938) 49.22	(1.406) 35.71		
B	12	E	19						
A	13	F	23	1.438-18 UNEF	(1.703) 43.51	(2.188) 54.43	(1.531) 38.89		
B	14	F	23						
C	15	F	23						
A	16	G	25						
B	17	G	25	1.562-18 UNEF	(1.825) 46.35	(2.688) 68.26	(1.781) 45.24		
C	18	G	25						
D	19	G	25						
A	20	H	29	1.875-16 UN	(2.143) 54.43	(2.688) 68.26	(1.781) 45.24		
B	21	H	29						
A	22	J	33	2.062-16 UNS	(2.329) 59.16	(2.688) 68.26	(1.781) 45.24		
A	23	J	33						
B	24	A	11	.750-20 UNEF	(1.028) 26.11	(1.188) 30.17	(1.031) 26.19		
C	25	A	11						
C	26	B	13			.875-20 UNEF	(1.141) 28.98	(1.438) 36.52	(1.156) 29.36
D	27	B	13						
E	28	C	15	1.000-20 UNEF	(1.263) 32.08	(1.688) 42.87	(1.281) 32.54		



* Dimensions in (inches) mm

* Dimensions in (inches) mm

M28840/8 90° EMI/RFI ENVIRONMENTAL BACKSHELL

Backshell Shell Size	DASH #	Military Shell Size	Shell Size	X Ref. Dimension	Y Ref. Dimension	H Max. Style A	N Max. Style B	
A	01	A	11	(1.281) 32.54	(.938) 23.82	(5.332) 134.43	(2.962) 75.23	
A	02	B	13		(.938) 23.82	(5.332) 134.43	(2.962) 75.23	
B	03	B	13		(1.125) 28.57	(5.332) 34.43	(2.962) 75.23	
A	04	C	15		(.938) 23.82	(5.457) 138.61	(3.087) 78.41	
B	05	C	15		(1.125) 28.57	(5.457) 138.61	(3.087) 78.41	
C	06	C	15		(1.312) 33.32	(5.457) 138.61	(3.087) 78.41	
D	07	C	15		(1.593) 40.62	(5.682) 144.32	(3.312) 84.12	
A	08	D	17		(1.312) 33.32	(5.682) 144.32	(3.312) 84.12	
B	09	D	17		(1.312) 33.32	(1.593) 40.62	(5.713) 145.11	(3.343) 84.91
C	10	D	17		(1.406) 35.71	(1.750) 44.45	(5.807) 147.50	(3.437) 87.30
A	11	E	19	(1.281) 32.54	(1.312) 33.32	(5.682) 144.32	(3.312) 84.12	
B	12	E	19	(1.406) 35.71	(1.750) 44.45	(5.832) 148.13	(3.462) 87.93	
A	13	F	23	(1.312) 33.32	(1.593) 40.62	(5.738) 145.28	(3.36x=) 85.55	
B	14	F	23	(1.406) 35.71	(1.750) 44.45	(5.832) 148.13	(3.462) 87.93	
C	15	F	23	(1.593) 40.46	(2.093) 53.16	(6.019) 152.88	(3.649) 92.68	
A	16	G	25	(1.406) 35.71	(1.750) 44.45	(5.832) 148.13	(3.462) 87.93	
B	17	G	25	(1.593) 40.46	(2.093) 53.16	(6.019) 152.88	(3.649) 92.68	
C	18	G	25	(1.593) 40.46	(2.093) 53.16	(6.144) 156.06	(3.774) 95.86	
D	19	G	25	(1.625) 41.28	(2.343) 59.51	(6.176) 156.87	(3.806) 96.62	
A	20	H	29	(1.593) 40.46	(2.093) 53.16	(6.144) 156.06	(3.774) 95.86	
B	21	H	29	(1.625) 41.28	(2.343) 59.51	(6.176) 156.87	(3.806) 96.62	
A	22	J	33	(1.625) 41.28	(2.343) 59.51	(6.426) 163.22	(4.056) 103.02	
A	23	J	33	(1.900) 48.26	(2.750) 59.85	(6.701) 170.21	(4.33) 110.01	
B	24	A	11	(1.281) 32.54	(1.125) 28.57	(5.332) 135.43	(2.962) 75.23	
C	25	A	11		(5.457) 138.61	(3.087) 78.41		
C	26	B	13		(5.457) 138.61	(3.087) 78.41		
C	27	B	13		(5.682) 144.32	(3.312) 84.12		
B	28	C	15		(5.682) 144.32	(3.312) 84.12		

Backshell Shell Size	DASH #	Military Shell Size	Shell Size	Cable Entry		E Max.	F Max.	V Thread Class 2	
				Min.	Max.				
A	01	A	11	(.188) 4.77	(.312) 7.92	(1.156) 29.36	(2.614) 66.40	.625-24 UNEF	
A	02	B	13	(.188) 4.77	(.312) 7.92			.625-24 UNEF	
B	03	B	13	(.281) 7.14	(.438) 11.12			.750-20 UNEF	
A	04	C	15	(.188) 4.77	(.312) 7.92	(1.281) 32.54	(2.864) 72.75	.625-24 UNEF	
B	05	C	15	(.281) 7.14	(.438) 11.12			.750-20 UNEF	
C	06	C	15	(.344) 8.74	(.562) 14.27			.875-20 UNEF	
D	07	C	15	(.438) 11.12	(.750) 19.05	(1.406) 35.71	(3.114) 79.10	1.188-18 UNEF	
A	08	D	17	(.375) 9.52	(.625) 15.87			1.000-20 UNEF	
B	09	D	17	(.438) 11.12	(.750) 19.05			1.188-18 UNEF	
C	10	D	17	(.625) 15.87	(.938) 23.82	(1.531) 38.89	(3.364) 85.45	1.438-18 UNEF	
A	11	E	19	(.375) 9.52	(.625) 15.87	(1.406) 35.71		1.000-20 UNEF	
B	12	E	19	(.625) 15.87	(.938) 23.82	(1.531) 38.89		1.438-18 UNEF	
A	13	F	23	(.438) 11.12	(.750) 19.05	(1.406) 25.71	(3.614) 91.80	1.188-18 UNEF	
B	14	F	23	(.625) 15.87	(.938) 23.82	(1.531) 38.89		1.438-18 UNEF	
C	15	F	23	(.812) 20.62	(1.188) 30.17	(1.781) 45.24		1.750-18 UNEF	
A	16	G	25	(.625) 15.87	(.938) 23.82	(1.531) 38.89	(3.614) 91.80	1.438-18 UNEF	
B	17	G	25	(.812) 20.62	(1.188) 30.17	(1.781) 45.24		1.750-18 UNS	
C	18	G	25	(.875) 22.23	(1.250) 31.75			2.000-16 UNS	
D	19	G	25	(1.000) 25.40	(1.380) 35.05	(2.156) 54.76	(4.114) 104.50	1.750-18 UNS	
A	20	H	29	(.812) 20.62	(1.188) 30.17	(1.781) 45.24		2.000-18 UNS	
B	21	H	29	(1.000) 25.40	(1.380) 35.05	(2.156) 54.76		2.000-18 UNS	
A	23	J	33	(1.380) 35.05	(1.000) 25.40	(2.281) 57.94	(1.156) 29.36	2.250-16 UNS	
B	24	A	11	(1.625) 41.26	(1.250) 31.75			.750-20 UNEF	
C	25	A	11	(.438) 11.12	(.281) 7.14	(1.156) 29.36		(2.614) 66.40	(1.156) 29.36
C	26	B	13	(.562) 14.27	(.344) 8.74	(1.281) 32.54		(2.864) 72.75	(1.156) 29.36
D	27	B	13	(.562) 14.27	(.344) 8.74	(1.281) 32.54		(2.864) 72.75	(1.156) 29.36
E	28	C	15	(.625) 15.87	(.375) 9.52	(1.406) 35.71		(3.114) 79.10	(1.281) 32.54

* Dimensions in (inches) mm

M28840/9 45° EMI/RFI ENVIRONMENTAL BACKSHELL

M28840/9	16	W	A
DESIGNATION	DASH #	MATERIAL & FINISH	BACKSHELL STYLE
QPL: M28840/9 Commercial: IN28840/9	See Table A	W: Aluminum, Cadmium Plate, O.D. over Electroless Nickel S: Aluminum -Zinc Nickel, Non-Reflective L: Aluminum-Tin-Zinc, Non-Reflective (Commercial only)	A: EMI Environmental B: Environmental

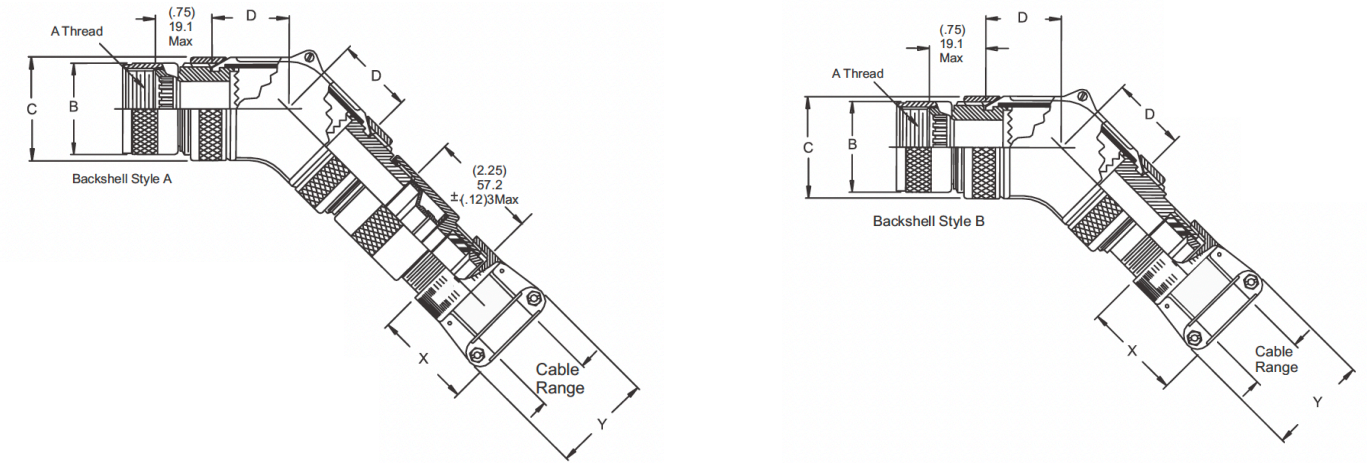

Backshell Shell Size	DASH #	Military Shell Size	A Thread Class 2B	B Ø Max.	C Ø Max.	D Max.		
A	01	A	.750-20 UNEF	(1.028) 26.11	(1.188) 30.18	(1.031) 26.19		
A	02	B	.875-20 UNEF	(1.141) 28.98				
B	03	B						
A	04	C	1.00-20 UNEF	(1.263) 32.08	(1.438) 36.53	(1.156) 29.36		
B	05	C						
C	06	C						
D	07	C	1.125-18 UNEF	(1.387) 35.23	(1.688) 42.88	(1.281) 32.54		
A	08	D						
B	09	D						
C	10	D	1.250-18 UNEF	(1.513) 38.43	(1.938) 49.23	(1.406) 35.71		
A	11	E						
B	12	E						
A	13	F	1.438-18 UNEF	(1.703) 43.51	(1.938) 49.23	(1.406) 35.71		
B	14	F						
C	15	F						
A	16	G	1.562-18 UNEF	(1.825) 46.35	(2.188) 55.58	(1.531) 38.89		
B	17	G						
C	18	G						
D	19	G	1.875-16 UN	(2.143) 54.43	(2.688) 68.28	(1.781) 45.24		
A	20	H						
B	21	H						
A	22	J	2.062-16 UNEF	(2.329) 59.16	(1.188) 30.18	(1.031) 26.19		
B	23	J					(1.438) 36.53	(1.156) 29.36
B	24	A						
C	25	A	.750-20 UNEF	(1.028) 26.11				
C	26	B	.875-20 UNEF	(1.141) 28.98				
D	27	B						
E	28	C	1.000-20 UNEF	(1.263) 32.08				

* Dimensions in (inches) mm

M28840/9 45° EMI/RFI ENVIRONMENTAL BACKSHELL

Backshell Shell Size	DASH #	Military Shell Size	Cable Range		E Ø Max.	F Max. Style A	H Max. Style B
			Min	Max.			
A	01	A	(.188) 4.77	(.312) 7.92	(1.156) 29.36	(5.879) 149.33	(4.199) 106.65
A	02	B	(.188) 4.77	(.312) 7.92		(5.879) 149.33	(4.199) 106.65
B	03	B	(.281) 7.14	(.438) 11.12		(5.932) 150.67	(4.252) 108.00
A	04	C	(.188) 4.77	(.312) 7.92	(1.281) 32.54	(6.092) 154.74	(4.412) 112.06
B	05	C	(.281) 7.14	(.438) 11.12		(6.146) 156.11	(4.466) 113.44
C	06	C	(.344) 8.74	(.562) 14.27		(6.202) 157.53	(4.522) 114.86
D	07	C	(.438) 11.12	(.750) 19.05	(1.406) 35.71	(6.533) 165.94	(4.853) 123.27
A	08	D	(.375) 9.82	(.625) 15.87		(6.413) 162.89	(4.733) 120.22
B	09	D	(.438) 11.12	(.750) 19.05		(6.533) 165.94	(4.853) 123.27
C	10	D	(.625) 15.87	(.938) 23.82	(1.531) 38.89	(6.636) 168.55	(4.956) 125.88
A	11	E	(.375) 9.52	(.625) 15.87	(1.406) 35.71	(6.413) 162.89	(4.733) 120.22
B	12	E	(.625) 15.87	(.938) 23.82	(1.531) 38.89	(6.846) 173.89	(5.166) 131.22
A	13	F	(.438) 11.12	(.750) 19.05	(1.406) 25.71	(6.747) 171.37	(5.067) 128.70
B	14	F	(.625) 15.87	(.938) 23.82	(1.531) 38.89	(6.846) 173.89	(5.166) 131.22
C	15	F	(.812) 20.62	(1.188) 30.17	(1.781) 45.24	(7.103) 180.42	(5.423) 138.23
A	16	G	(.625) 15.87	(.938) 23.82	(1.531) 38.89	(6.846) 173.89	(5.156) 130.96
B	17	G	(.812) 20.62	(1.188) 30.17	(1.781) 45.24	(7.103) 180.42	(5.423) 138.23
C	18	G	(.875) 22.23	(1.250) 31.75		(7.316) 185.83	(5.636) 143.15
D	19	G	(1.000) 25.40	(1.380) 35.05		(7.425) 188.60	(5.745) 145.92
A	20	H	(.812) 20.62	(1.188) 30.17	(1.781) 45.24	(7.316) 185.83	(5.636) 143.15
B	21	H	(1.000) 25.40	(1.380) 35.05	(2.156) 54.76	(7.425) 188.60	(5.745) 145.92
A	22	J	(1.380) 35.05	(1.000) 25.40	(2.281) 57.94	(7.852) 199.44	(6.127) 156.77
B	23	J	(1.625) 41.28	(1.250) 31.75		(6.454) 163.93	(6.454) 163.93
B	24	A	(.438) 11.12	(.281) 7.14		(1.156) 29.36	(5.932) 150.67
C	25	A	(.562) 14.27	(.344) 8.74	(1.281) 32.54	(6.202) 157.53	(4.522) 114.86
C	26	B	(.562) 14.27	(.344) 8.74	(1.281) 32.54	(6.202) 157.53	(4.522) 114.86
D	27	B	(.625) 15.87	(.375) 9.52	(1.406) 35.71	(6.413) 162.89	(4.733) 120.22
E	28	C	(.625) 15.87	(.375) 9.50		(6.413) 162.89	(4.733) 120.22

Backshell Shell Size	DASH #	Military Shell Size	V Thread Class	X Ref. Dimension	Y Ref. Dimension
A	01	A	.625-24 UNEF	(1.281) 32.5	(.938) 23.82
A	02	B	.625-24 UNEF		(.938) 23.82
B	03	B	.750-20 UNEF		(1.125) 28.57
A	04	C	.625-24 UNEF		(.938) 23.82
B	05	C	.750-20 UNEF		(1.125) 28.57
C	06	C	.875-20 UNEF		(1.312) 33.32
D	07	C	1.188-18 UNEF	(1.312) 33.32	(1.593) 40.62
A	08	D	1.000-20 UNEF	(1.281) 32.54	(1.312) 33.32
B	09	D	1.188-18 UNEF	(1.312) 33.32	(1.593) 40.62
C	10	D	1.438-18 UNEF	(1.406) 35.71	(1.750) 44.45
A	11	E	1.000-20 UNEF	(1.281) 32.54	(1.312) 33.32
B	12	E	1.438-18 UNEF	(1.406) 35.71	(1.750) 44.45
A	13	F	1.188-18 UNEF	(1.312) 33.32	(1.593) 40.62
B	14	F	1.438-18 UNEF	(1.406) 35.71	(1.750) 44.45
C	15	F	1.750-18 UNS	(1.593) 40.46	(2.093) 53.16
A	16	G	1.438-18 UNEF	(1.406) 35.71	(1.750) 44.45
B	17	G	1.750-18 UNS	(1.593) 40.46	(2.093) 53.16
C	18	G	1.750-18 UNS	(1.593) 40.46	(2.093) 53.16
D	19	G	2.000-16 UNS	(1.625) 41.28	(2.343) 59.51
A	20	H	1.750-18 UNS	(1.593) 40.46	(2.093) 53.16
B	21	H	2.000-18 UNS	(1.625) 41.28	(2.343) 59.51
A	22	J	2.000-18 UNS	(1.625) 41.28	(2.343) 59.51
B	23	J	2.250-16 UNS	(1.900) 48.26	(2.750) 69.85
B	24	A	.750-20 UNEF	(1.281) 32.54	(1.125) 28.57
C	25	A	.875-20 UNEF		(1.312) 33.32
C	26	B	.875-20 UNEF		
D	27	B	1.000-20 UNEF		
E	28	C	1.000-20 UNEF		

* Dimensions in (inches) mm

M28840/10 WALL MOUNT RECEPTACLE CONNECTOR

M28840/10	A	G	1	P	1
DESIGNATION	MATERIAL & MATERIAL & FINISH	SHELL SIZE	INSERT	CONTACT	KEY POSITION
QPL: M28840/10 Commercial: IN28840/10	A: Aluminum, Cadmium Plate, O.D. over Electroless Nickel S: Aluminum-Zinc Nickel, Non-Reflective L: Aluminum-Tin-Zinc, Non-Reflective (Commercial only)	A: 11 B: 13 C: 15 D: 17 E: 19 F: 23 G: 25 H: 29 J: 33	1	F: Pin, Size 20 G: Socket, Size 20 P: Pin, Size, 22 S: Socket, Size, 22 D: Pin, Size, 28 E: Socket, Size, 28	1 2 3 4 5 6

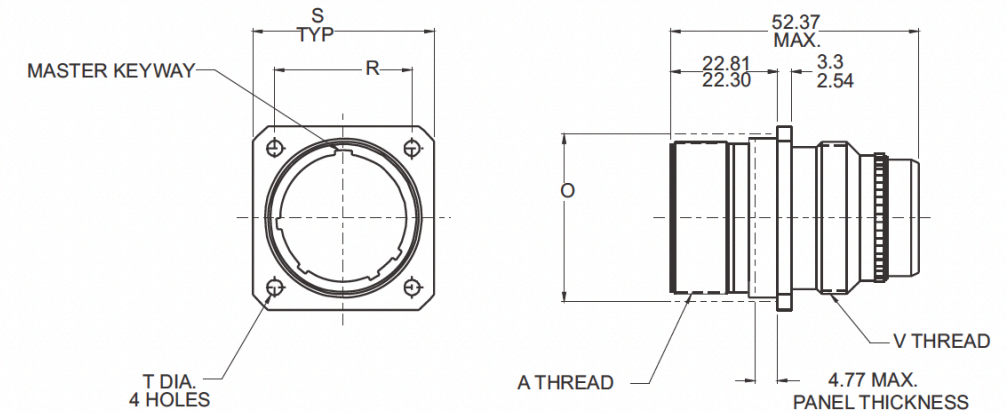

Military Shell Size	Shell Size	A Thread Class 2A	V Thread Class 2A	O Ref. Mating Hole	R True Position ϕ to ϕ	S	T Ø
A	11	.750-1P-2L-D.S.	.750-20 UNEF	(.812) 20.62	(.750) 19.05	(1.043) 26.49 (1.003) 25.48	(.130) 3.30 (.115) 2.92
B	13	.875-1P-2L-D.S.	.875-20 UNEF	(.937) 23.80	(.843) 21.41	(1.158) 29.41 (1.118) 28.40	
C	15	1.062-1P-2L-D.S.	1.000-20 UNEF	(1.124) 28.55	(.968) 24.59	(1.278) 32.46 (1.238) 31.45	
D	17	1.125-1P-2L-D.S.	1.125-18 UNEF	(1.187) 30.15	(1.01) 25.78	(1.403) 35.64 (1.363) 34.62	
E	19	1.312-1P-2L-D.S.	1.250-18 UNEF	(1.374) 34.90	(1.140) 28.96	(1.528) 38.81 (1.488) 37.80	
F	23	1.500-1P-2L-D.S.	1.437-18 UNEF	(1.562) 39.67	(1.281) 32.54	(1.738) 44.15 (1.698) 43.13	
G	25	1.625-1P-2L-D.S.	1.562-18 UNEF	(1.687) 42.85	(1.392) 35.36	(1.838) 46.69 (1.798) 45.67	(.157) 3.99 (.142) 3.61
H	29	1.812-1P-2L-D.S.	1.875-16 UN	(1.874) 47.60	(1.568) 39.83	(2.158) 54.81 (2.118) 53.80	
J	33	2.000-1P-2L-D.S.	2.062-16 UNS	(2.062) 52.37	(1.734) 44.04	(2.348) 59.64 (2.308) 58.62	(.183) 4.65 (.168) 4.27

www.powell.com
 800-235-7880
 pcdinfo@powell.com

* Dimensions in (inches) mm

M28840/11 IN-LINE RECEPACLE CONNECTOR

M28840/11	A	G	1	P	1
DESIGNATION	MATERIAL & FINISH	SHELL SIZE	INSERT	CONTACT	KEY POSITION
QPL: M28840/11 Commercial: IN28840/11	A: Aluminum, Cadmium Plate, O.D. over Electroless Nickel S: Aluminum-Zinc Nickel, Non-Reflective L: Aluminum-Tin-Zinc, Non-Reflective (Commercial only)	A: 11 B: 13 C: 15 D: 17 E: 19 F: 23 G: 25 H: 29 J: 33	1	F: Pin, Size 20 G: Socket, Size 20 P: Pin, Size, 22 S: Socket, Size, 22 D: Pin, Size, 28 E: Socket, Size, 28	1 2 3 4 5 6

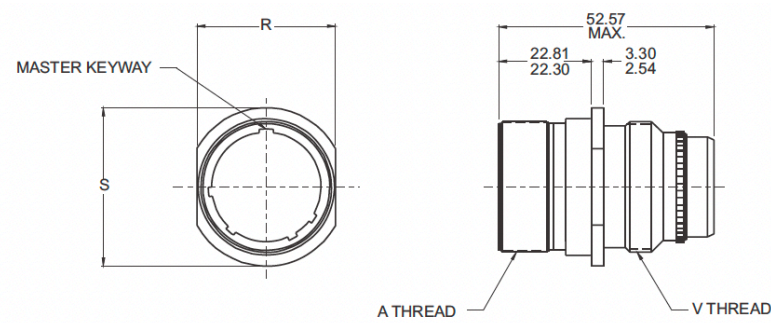

M28840/12 BOX MOUNT RECEPACLE CONNECTOR

M28840/12	A	2	G	1	P	1
DESIGNATION	MATERIAL & FINISH	LENGTH	SHELL SIZE	INSERT	CONTACT	KEY POSITION
QPL: M28840/12 Commercial: IN28840/12	A: Aluminum, Cadmium Plate, O.D. over Electroless Nickel S: Aluminum-Zinc Nickel, Non-Reflective L: Aluminum-Tin-Zinc, Non-Reflective (Commercial only)	Omit: Standard - (Figure 1) 2: Long - (Figure 2)	A: 11 B: 13 C: 15 D: 17 E: 19 F: 23 G: 25 H: 29 J: 33	1	F: Pin, Size 20 G: Socket, Size 20 P: Pin, Size, 22 S: Socket, Size, 22 D: Pin, Size, 28 E: Socket, Size, 28	1 2 3 4 5 6

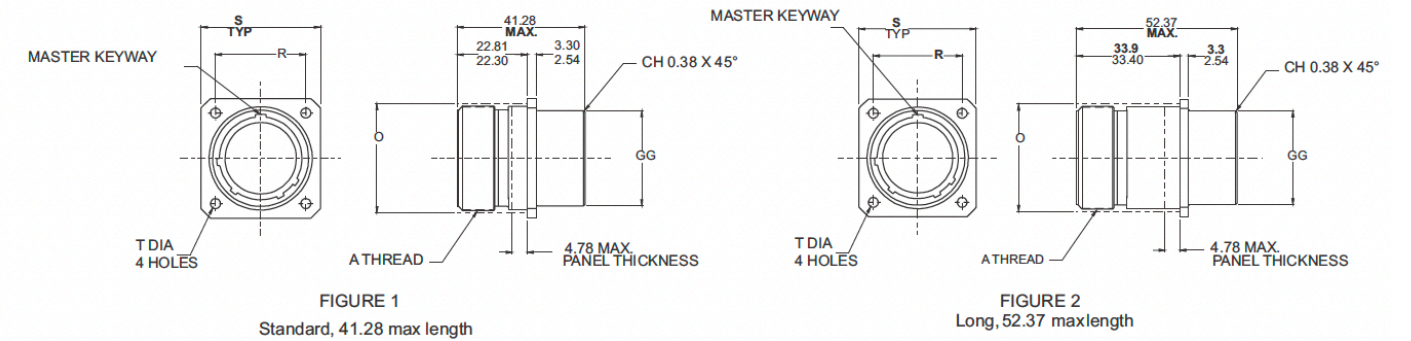

Military Shell Size	Shell Size	A Thread Class 2A	V Thread Class 2A	R	S Ø
A	11	.750-.1P-.2L-D.S.	.750-20 UNEF	(.768) 19.51 (.758) 19.25	(.963) 24.46 (.943) 23.95
B	13	.875-.1P-.2L-D.S.	.875-20 UNEF	(.893) 22.68 (.883) 22.43	(1.088) 27.63 (1.063) 27.13
C	15	1.062-.1P-.2L-D.S.	1.000-20 UNEF	(1.080) 27.43 (1.070) 27.18	(1.275) 32.38 (1.255) 31.88
D	17	1.125-.1P-.2L-D.S.	1.125-18 UNEF	(1.143) 29.03 (1.133) 28.78	(1.338) 33.98 (1.318) 33.48
E	19	1.312-.1P-.2L-D.S.	1.250-18 UNEF	(1.330) 33.78 (1.320) 33.53	(1.525) 38.74 1.505 38.23
F	23	1.500-.1P-.2L-D.S.	1.437-18 UNEF	(1.518) 38.56 (1.508) 38.30	(1.713) 43.51 (1.693) 43.00
G	25	1.625-.1P-.2L-D.S.	1.562-18 UNEF	(1.643) 41.73 (1.633) 41.48	(1.838) 46.09 (1.818) 46.18
H	29	1.812-.1P-.2L-D.S.	1.875-16 UN	(1.893) 48.08 (1.883) 47.83	(2.088) 53.04 (2.068) 52.53
J	33	2.000-.1P-.2L-D.S.	2.062-16 UNS	(2.080) 52.83 (2.070) 52.58	(2.275) 57.78 (2.255) 57.28

Military Shell Size	Shell Size	N Ø Max.	O Ref. Mating Hole	R True Position ℄ to ℄	S	T	GG Ø Max.
A	11	(.750) 19.05	(.812) 20.62	(.750) 19.05	(1.043) 26.49 (1.003) 25.48	(1.130) 3.30 (.115) 2.92	(.758) 19.25
B	13	(.875) 22.22	(.937) 23.80	(.843) 21.41	(1.158) 29.41 (1.118) 28.40		(.880) 22.35
C	15	(1.062) 26.97	(1.124) 28.55	(.968) 24.59	(1.278) 32.46 (1.238) 31.45		(1.005) 25.53
D	17	(1.125) 28.58	(1.187) 30.15	(1.015) 25.78	(1.403) 35.64 (1.363) 34.62		(1.130) 28.70
E	19	(1.312) 33.32	(1.374) 34.90	(1.140) 28.96	(1.528) 38.81 (1.488) 37.80		(1.255) 31.88
F	23	(1.500) 38.10	(1.562) 39.67	(1.281) 32.54	(1.738) 44.15 (1.698) 43.13		(1.443) 36.65
G	25	(1.625) 41.28	(1.687) 42.85	(1.392) 35.36	(1.838) 46.69 (1.798) 45.67	(1.157) 3.99 (.142) 3.61	(1.567) 39.80
H	29	(1.812) 46.02	(1.874) 47.60	(1.568) 39.83	(2.158) 54.81 (2.118) 53.80		(1.880) 47.75
J	33	(2.000) 50.80	(2.062) 52.37	(1.734) 44.04	(2.343) 59.64 (2.308) 58.62		(1.183) 4.65 (.168) 4.27

* Dimensions in (inches) mm

* Dimensions in (inches) mm



M28840/13 PROTECTIVE RECEPTACLE COVER

M28840/13	G	A	W
DESIGNATION	SHELL SIZE	CHAIN ATTACHMENT STYLE	MATERIAL & FINISH
QPL: M28840/13 Commercial: IN28840/13	A: 11 B: 13 C: 15 D: 17 E: 19 F: 23 G: 25 H: 29 J: 33	A: Link Chain WITH Fastener B: Link Chain WITH Ring for Jam-Nut Mounting Receptacle C: Link Chain WITH Ring for Cable-Connecting Receptacle	W: Aluminum, Cadmium Plate, O.D. over Electroless Nickel S: Aluminum-Zinc Nickel, Non-Reflective L: Aluminum-Tin-Zinc, Non-Reflective (Commercial only)

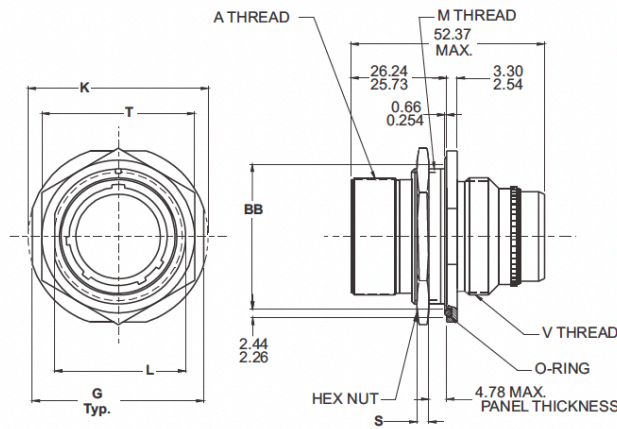

Military Shell Size	Shell Size	E Thread Class 2A	F Ø Max.	H ±(0.010) ±(0.25)	J Ø ±(0.05) ±(0.13)	G ±(0.05) ±(0.13)	
A	11	.750-.1P-.2L-D.S.	(1.028) 26.21	(.890) 22.61	(1.130) 3.30	(.765) 19.43	
B	13	.875-.1P-.2L-D.S.	(1.141) 23.98	(1.015) 25.78		(.890) 22.61	
C	15	1.062-.1P-.2L-D.S.	(1.263) 32.08	(1.203) 30.56		(1.015) 25.78	
D	17	1.125-.1P-.2L-D.S.	(1.387) 35.23	(1.265) 32.13		(1.140) 28.96	
E	19	1.312-.1P-.2L-D.S.	(1.513) 38.43	(1.453) 36.91		(1.265) 32.13	
F	23	1.500-.1P-.2L-D.S.	(1.703) 43.51	(1.640) 41.66		(1.453) 36.91	
G	25	1.625-.1P-.2L-D.S.	(1.825) 46.35	(1.765) 44.83	(1.156) 3.96	(1.577) 40.06	
H	29	1.812-.1P-.2L-D.S.	(2.143) 54.43	(1.953) 49.61		(1.890) 48.01	
J	33	2.000-.1P-.2L-D.S.	(2.329) 59.16	(2.140) 54.36		(1.93) 4.90	(2.077) 52.76

M28840/14 JAM NUT RECEPTACLE CONNECTOR

M28840/14	A	G	1	P	1
DESIGNATION	MATERIAL & FINISH	SHELL SIZE	INSERT	CONTACT	KEY POSITION
QPL: M28840/14 Commercial: IN28840/14	A: Aluminum, Cadmium Plate, O.D. over Electroless Nickel S: Aluminum-Zinc Nickel, Non-Reflective L: Aluminum-Tin-Zinc, Non-Reflective (Commercial only)	A: 11 B: 13 C: 15 D: 17 E: 19 F: 23 G: 25 H: 29 J: 33	1	F: Pin, Size 20 G: Socket, Size 20 P: Pin, Size, 22 S: Socket, Size, 22 D: Pin, Size, 28 E: Socket, Size, 28	1 2 3 4 5 6

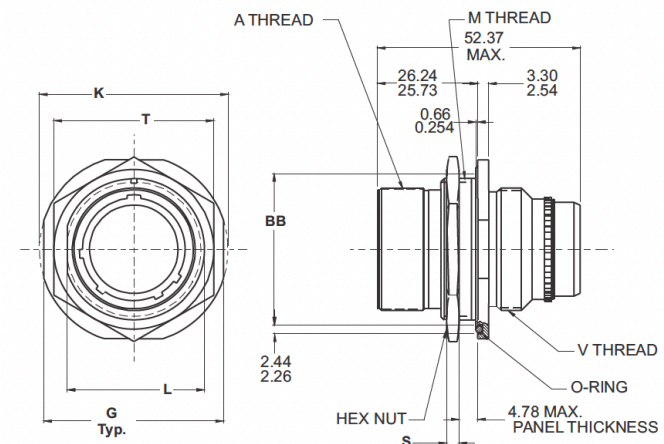

Military Shell Size	Shell Size	BB	G	K	L Across Flat	M Thread Class 2A	N Max.	P	R Max.	S Hex Nut Thickness	T ±.017(0.43)
A	11	(.979) 24.87	(1.274) 32.36	(1.368) 34.75	(.841) 21.36	7/8-20 UNEF	(0.750) 19.05	(.890) 22.61	(0.875)	(0.125) 3.17	(1.062) 26.97
A	11	(.969) 24.61	(1.254) 31.85	(1.348) 34.24	(.832) 21.13		19.05	(.880) 22.35	22.22		(1.188) 30.18
B	13	(1.104) 28.04	(1.399) 35.53	(1.508) 38.30	(.966) 24.54	1-20 UNEF	(0.875) 22.22	(1.015) 24.78	(1.000)		(1.375) 34.93
B	13	(1.094) 27.79	(1.379) 35.03	(1.488) 37.80	(.957) 24.31		22.22	(1.005) 25.53	25.40		(1.438) 36.53
C	15	(1.292) 32.82	(1.587) 40.31	(1.681) 42.70	(1.156) 29.29	1 3/16-18 UNEF	(1.062) 26.97	(1.203) 30.56	(1.188)		(1.812) 46.02
C	15	(1.282) 32.56	(1.567) 39.80	(1.661) 42.19	(1.144) 29.06		26.97	(1.193) 30.30	30.18		(2.000) 50.80
D	17	(1.354) 34.39	(1.649) 41.88	(1.743) 44.27	(1.216) 30.89	1 1/4-18 UNEF	(1.125) 28.58	(1.265) 32.13	(1.250)	(2.188) 55.58	
D	17	(1.344) 34.14	(1.629) 41.38	(1.723) 43.76	(1.207) 30.66		28.58 28.58	(1.255) 31.88	31.75	(2.375) 69.85	
E	19	(1.542) 39.17	(1.837) 46.66	(1.931) 49.05	(1.403) 35.64	1 7/16-18 UNEF	(1.312) 33.32	(1.453) 36.91	(1.438)		
E	19	(1.532) 38.91	(1.817) 46.15	(1.911) 48.54	(1.394) 35.41		33.32	(1.443) 36.65	36.52		
F	23	(1.729) 43.92	(2.024) 51.41	(2.118) 53.80	(1.591) 40.41	1 5/8-18 UNEF	(1.500) 8.10	(1.640) 41.66	(1.625)		
F	23	(1.718) 43.66	(2.004) 50.90	(2.098) 53.29	(1.582) 40.18		8.10	(1.630) 41.40	41.28		
G	25	(1.854) 47.09	(2.149) 54.58	(2.243) 56.97	(1.716) 43.59	1 3/4-18 UNS	(1.625) 41.28	(1.765) 44.83	(1.750)		
G	25	(1.844) 46.84	(2.129) 54.08	(2.223) 56.46	(1.707) 43.36		41.28	(1.755) 44.58	44.45		
H	29	(2.042) 51.87	(2.337) 59.36	(2.435) 61.85	(1.903) 46.34	1 15/16-16 UN	(1.812)	(1.953) 49.61	(1.938)		
H	29	(2.032) 51.61	(2.317) 58.85	(2.415) 61.34	(1.894) 48.11		46.02	(1.943) 49.35	49.22		
J	33	(2.229) 56.62	(2.524) 64.11	(2.618) 66.50	(2.091) 53.11		(2.000)	(2.140) 54.36	(2.125)		
J	33	(2.219) 56.36	(2.504) 63.60	(2.598) 65.99	(2.082) 52.88	2 1/8-16 UN	50.80	(2.130) 54.10	53.98		

M28840/15 PROTECTIVE PLUG COVER

M28840/15	G	A	W
DESIGNATION	SHELL SIZE	CHAIN ATTACHMENT STYLE	MATERIAL & FINISH
QPL: M28840/15 Commercial: IN28840/15	A: 11 B: 13 C: 15 D: 17 E: 19 F: 23 G: 25 H: 29 J: 33	A: Link Chain WITH Fastener B: Link Chain WITH Ring for Jam-Nut Mounting Receptacle	W: Aluminum, Cadmium Plate, O.D. over Electroless Nickel S: Aluminum-Zinc Nickel, Non-Reflective L: Aluminum-Tin-Zinc, Non-Reflective (Commercial only)

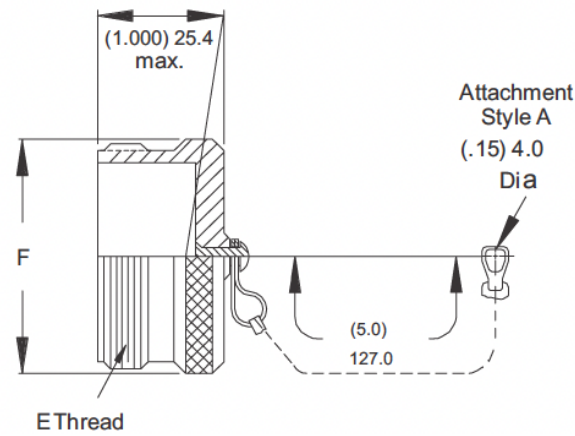

Military Shell Size	Shell Size	E Thread Class 2B	F Ø Max.
A	11	.750-1P-.2L-DS	(1.028) 26.21
B	13	.875-1P-.2L-DS	(1.141) 28.98
C	15	1.062-1P-.2L-DS	(1.263) 32.08
D	17	1.125-1P-.2L-DS	(1.387) 35.23
E	19	1.312-1P-.2L-DS	(1.108) 28.14
F	23	1.500-1P-.2L-DS	(1.293) 32.84
G	25	1.625-1P-.2L-DS	(1.454) 36.93
H	29	1.812-1P-.2L-DS	(1.620) 41.15
J	33	2.000-1P-.2L-DS	(1.812) 46.02

* Dimensions in (inches) mm

M28840/16 PLUG CONNECTOR

M28840/16	A	G	1	P	1
DESIGNATION	MATERIAL & FINISH	SHELL SIZE	INSERT	CONTACT	KEY POSITION
QPL: M28840/16 Commercial: IN28840/16	A: Aluminum, Cadmium Plate, O.D. over Electroless Nickel S: Aluminum-Zinc Nickel, Non-Reflective L: Aluminum-Tin-Zinc, Non-Reflective (Commercial only)	A: 11 B: 13 C: 15 D: 17 E: 19 F: 23 G: 25 H: 29 J: 33	1	F: Pin, Size 20 G: Socket, Size 20 P: Pin, Size, 22 S: Socket, Size, 22 D: Pin, Size, 28 E: Socket, Size, 28	1 2 3 4 5 6

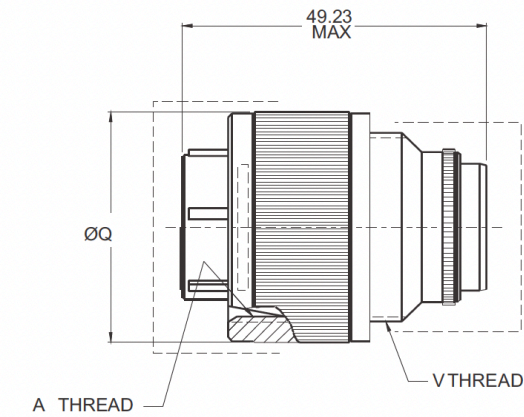

Military Shell Size	Shell Size	A Thread Class 2A	V Thread Class 2A	Q Ø Max.
A	11	.750-1P-.2L-DS	3/4-20 UNEF	(1.028) 26.11
B	13	.875-1P-.2L-DS	7/8-20 UNEF	(1.141) 28.98
C	15	1.062-1P-.2L-DS	1-20 UNEF	(1.263) 32.08
D	17	1.125-1P-.2L-DS	1 1/8-18 UNEF	(1.387) 35.23
E	19	1.312-1P-.2L-DS	1 1/4-18 UNEF	(1.513) 38.43
F	23	1.500-1P-.2L-DS	1 7/16-18 UNEF	(1.703) 43.26
G	25	1.625-1P-.2L-DS	1 9/16-18 UNEF	(1.825) 46.36
H	29	1.812-1P-.2L-DS	1 7/8-16 UN	(2.143) 54.43
J	33	2.000-1P-.2L-DS	2 1/16-16 UNS	(2.329) 59.16

* Dimensions in (inches) mm



M28840/17 PLUG CONNECTOR WITH STRAIGHT STRAIN RELIEF BACKSHELL

M28840/17	C	G	1	P	1
DESIGNATION	MATERIAL & FINISH	SHELL SIZE	INSERT	CONTACT	KEY POSITION
QPL: M28840/17 Commercial: IN28840/17	C: Class DJ: Aluminum Cadmium Plate U: Class ZJ Aluminum -Zinc Nickel, Non-Reflective M: Class TJ; Aluminum Tin Zinc, Non- Reflective (Commercial only)	A: 11 B: 13 C: 15 D: 17 E: 19 F: 23 G: 25 H: 29 J: 33	1	F: Pin, Size 20 G: Socket, Size 20 P: Pin, Size, 22 S: Socket, Size, 22 D: Pin, Size, 28 E: Socket, Size, 28	1 2 3 4 5 6

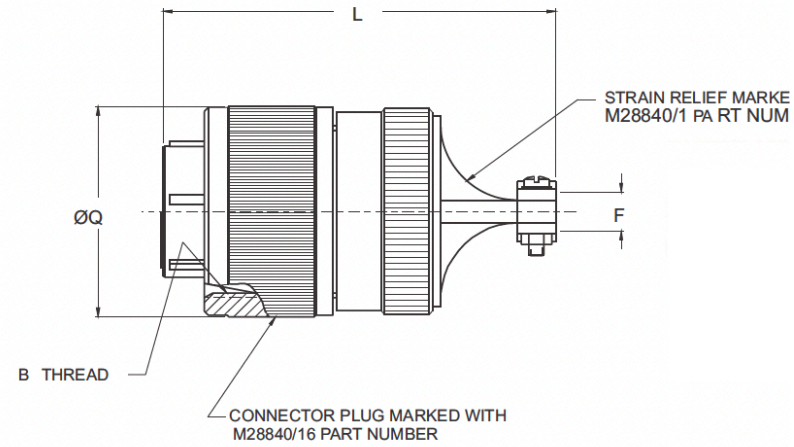

Military Shell Size	Shell Size	B Thread Class 2B	F Cable Entry		L Max.	Q Max.	Max O.D. Over Rear Clamps
			Max.	Min.			
A	11	.750-1P-.2L-DS	7.26 (0.286)	4.50 (.177)	61.92 (2.438)	26.11 (1.028)	21.13 (.832)
B	13	.875-1P-.2L-DS	7.26 (0.286)				
C	15	1.062-1P-.2L-DS	10.57 (.416)	6.35 (.250)	68.27 (2.688)	32.10 (1.263)	25.12 (.989)
D	17	1.125-1P-.2L-DS	12.10 (0.476)				
E	19	1.312-1P-.2L-DS	15.90 (.626)	8.84 (.348)	71.42 (2.812)	38.43 (1.513)	33.50 (1.319)
F	23	1.500-1P-.2L-DS	21.10 (.831)	10.90 (.429)	74.63 (2.938)	43.25 (1.703)	39.55 (1.557)
G	25	1.625-1P-.2L-DS	24.28 (.956)	13.28 (.523)	77.78 (3.062)	46.36 (1.825)	41.99 (1.653)
H	29	1.812-1P-.2L-DS	27.45 (1.081)	16.33 (.643)	80.98 (3.188)	54.43 (2.143)	46.20 (1.819)
J	33	2.000-1P-.2L-DS	30.15 (1.187)	17.88 (.704)	85.73 (3.375)	59.16 (2.329)	51.31 (2.020)

* Dimensions in (inches) mm

M28840/18 PLUG CONNECTOR WITH 90° STRAIN RELIEF BACKSHELL

M28840/18	C	G	1	P	1
DESIGNATION	MATERIAL & FINISH	SHELL SIZE	INSERT	CONTACT	KEY POSITION
QPL: M28840/18 Commercial: IN28840/18	C: Class DJ: Aluminum Cadmium Plate U: Class ZJ Aluminum -Zinc Nickel, Non-Reflective M: Class TJ; Aluminum Tin Zinc, Non- Reflective (Commercial only)	A: 11 B: 13 C: 15 D: 17 E: 19 F: 23 G: 25 H: 29 J: 33	1	F: Pin, Size 20 G: Socket, Size 20 P: Pin, Size, 22 S: Socket, Size, 22 D: Pin, Size, 28 E: Socket, Size, 28	1 2 3 4 5 6

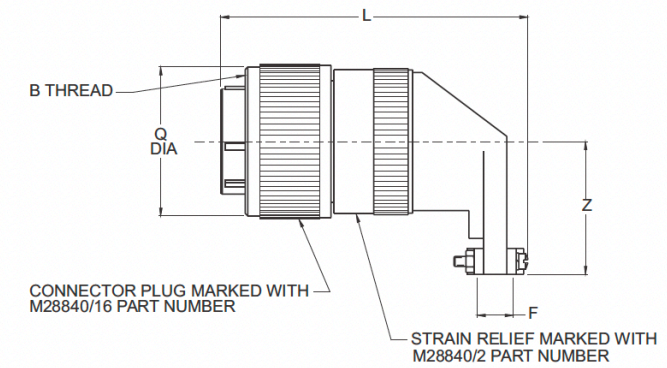

Military Shell Size	Shell Size	B Thread Class 2B	F Cable Entry		L Max.	Q Max.	Z Max.	Max O.D. Over Rear Clamps
			Max.	Min.				
A	11	.750-1P-.2L-DS	(.286) 7.26	(.177) 4.49	(2.562) 65.07	(1.028) 26.11	(1.141) 28.98	(1.094) 27.79
B	13	.875-1P-.2L-DS	(.286) 7.26					
C	15	1.062-1P-.2L-DS	(.416) 10.56	(.250) 6.35	(2.750) 69.85	(1.263) 32.08	(1.056) 26.32	(1.989) 25.12
D	17	1.125-1P-.2L-DS	(.476) 12.09					
E	19	1.312-1P-.2L-DS	(.626) 15.90	(.348) 8.83	(3.000) 76.2	(1.513) 38.43	(1.296) 32.92	(1.319) 33.50
F	23	1.500-1P-.2L-DS	(.831) 21.10	(.429) 10.89	(3.125) 79.37	(1.703) 43.25	(1.358) 34.49	(1.557) 39.55
G	25	1.625-1P-.2L-DS	(.956) 24.28	(.523) 13.28	(3.250) 82.55	(1.825) 46.25	(1.420) 36.07	(1.653) 41.99
H	29	1.812-1P-.2L-DS	(1.081) 27.45	(.643) 16.33	(3.375) 85.72	(2.143) 54.43	(1.634) 41.50	(1.819) 46.20
J	33	2.000-1P-.2L-DS	(1.187) 30.14	(.704) 17.88	(3.438) 87.32	(2.329) 59.15	(1.859) 47.22	(2.020) 51.31

* Dimensions in (inches) mm



M28840/19 PLUG CONNECTOR WITH 45° STRAIN RELIEF BACKSHELL

M28840/19	C	G	1	P	1
DESIGNATION	MATERIAL & FINISH	SHELL SIZE	INSERT	CONTACT	KEY POSITION
QPL: M28840/19 Commercial: IN28840/19	C: Class DJ: Aluminum Cadmium Plate U: Class ZJ Aluminum -Zinc Nickel, Non-Reflective M: Class TJ; Aluminum Tin Zinc, Non- Reflective (Commercial only)	A: 11 B: 13 C: 15 D: 17 E: 19 F: 23 G: 25 H: 29 J: 33	1	F: Pin, Size 20 G: Socket, Size 20 P: Pin, Size, 22 S: Socket, Size, 22 D: Pin, Size, 28 E: Socket, Size, 28	1 2 3 4 5 6

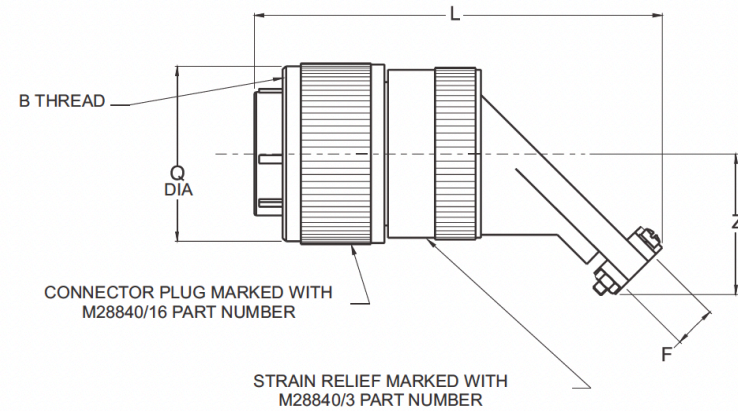

Military Shell Size	Shell Size	B Thread Class 2B	F Cable Entry		L Max.	Q Max.	Z Max.	Max O.D. Over Rear Clamps
			Max.	Min.				
A	11	.750-1P-.2L-DS	(.286) 7.26	(.177) 4.49	(3.125) 79.73	(1.028) 26.11	(.928) 23.57	(.832) 21.13
B	13	.875-1P-.2L-DS	(.286) 7.26		(3.125) 75.37	(1.141) 28.98	(.928) 23.57	
C	15	1.062-1P-.2L-DS	(.416) 10.56	(.250) 6.35	(3.250) 82.55	(1.263) 32.08	(.991) 25.17	(.989) 25.12
D	17	1.125-1P-.2L-DS	(.476) 12.09	(.291) 7.39	(3.312) 84.12	(1.387) 35.22	(1.110) 28.19	(1.094) 27.78
E	19	1.312-1P-.2L-DS	(.626) 15.90	(.348) 8.83	(3.375) 85.725	(1.513) 38.43	(1.172) 29.76	(1.319) 33.50
F	23	1.500-1P-.2L-DS	(.831) 21.10	(.429) 10.89	(3.438) 87.32	(1.703) 43.25	(1.235) 31.39	(1.557) 39.54
G	25	1.625-1P-.2L-DS	(.956) 24.28	(.523) 13.28	(3.500) 88.9	(1.825) 46.35	(1.297) 32.94	(1.653) 41.98
H	29	1.812-1P-.2L-DS	(1.081) 27.45	(.643) 16.33	(3.750) 95.25	(2.143) 54.43	(1.543) 39.19	(1.819) 46.20
J	33	2.000-1P-.2L-DS	(1.187) 30.14	(.704) 17.88	(3.875) 98.425	(2.329) 59.15	(1.668) 42.36	(2.020) 51.30

M28840/20 RECEPTACLE CONNECTOR WITH STRAIGHT EMI/RFI BACKSHELL

M28840/20	C	G	1	A	A	P	1
DESIGNATION	MATERIAL & FINISH	SHELL SIZE	INSERT	BACKSHELL SIZE	BACKSHELL STYLE	CONTACT	KEY POSITION
QPL: M28840/20 Commercial: IN28840/20	C: Class DJ: Aluminum Cadmium Plate U: Class ZJ Aluminum -Zinc Nickel, Non-Reflective M: Class TJ; Aluminum Tin Zinc, Non- Reflective (Commercial only)	A: 11 B: 13 C: 15 D: 17 E: 19 F: 23 G: 25 H: 29 J: 33	1	A B C D	A: EMI Environmental B: Environmental	F: Pin, Size 20 G: Socket, Size 20 P: Pin, Size, 22 S: Socket, Size, 22 D: Pin, Size, 28 E: Socket, Size, 28	1 2 3 4 5 6

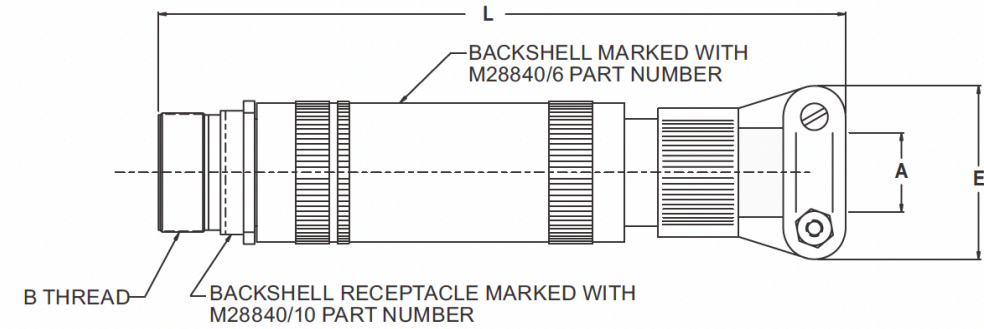

Military Shell Size	Shell Size	Backshell Shell Size	A Cable Entry		B Thread Class 2B	E Max.	L Max.
			Max.	Min.			
A	11	A	(.312) 7.92	(.188) 4.77	.750-1P-.2L-DS	(.938) 23.82	(6.625) 168.27
A	11	B	(.438) 11.12	(.281) 7.13		(1.125) 31.75	(6.625) 168.27
A	11	C	(.562) 14.27	(.344) 8.73		(1.312) 33.32	(6.625) 168.27
B	13	A	(.312) 7.92	(.188) 4.77	.875-1P-.2L-DS	(.938) 23.82	(6.625) 168.27
B	13	B	(.438) 11.12	(.281) 7.13		(1.125) 31.75	(6.625) 168.27
B	13	C	(.562) 14.27	(.344) 8.79		(1.312) 33.32	(6.625) 168.27
B	13	D	(.652) 16.546	(.375) 9.52	1.062-1P-.2L-DS	(1.312) 33.32	(7.125) 184.15
C	15	A	(.438) 11.12	(.281) 7.13		(1.125) 31.75	(6.625) 168.27
C	15	B	(.562) 14.27	(.344) 8.73		(1.312) 33.32	(6.625) 168.27
C	15	C	(.625) 15.87	(.375) 9.52	1.125-1P-.2L-DS	(1.312) 33.32	(7.125) 180.97
C	15	D	(.750) 19.05	(.438) 11.12		(1.593) 40.46	(7.188) 182.57
C	15	E	(.312) 7.92	(.188) 4.77		(.938) 23.82	(6.625) 168.27
D	17	A	(.625) 16.56	(.375) 9.52	1.312-1P-.2L-DS	(1.312) 33.32	(7.125) 180.97
D	17	B	(.750) 19.05	(.438) 11.12		(1.593) 40.46	(7.188) 182.57
D	17	C	(.938) 23.82	(.625) 15.87		(1.750) 44.45	(7.188) 182.57
E	19	A	(.625) 15.82	(.375) 9.52	1.500-1P-.2L-DS	(1.312) 33.32	(7.125) 180.97
E	19	B	(.938) 23.82	(.625) 15.87		(1.750) 44.45	(7.250) 184.15
F	23	A	(.750) 19.05	(.438) 11.12		(1.593) 40.46	(7.688) 195.27
F	23	B	(.938) 23.82	(.625) 15.87	1.625-1P-.2L-DS	(1.750) 44.45	(7.812) 198.42
F	23	C	(1.188) 30.17	(.812) 20.62		(2.093) 53.28	(7.938) 201.62
G	25	A	(.938) 23.82	(.625) 15.87		(1.750) 44.45	(7.750) 196.85
G	25	B	(1.188) 30.17	(.812) 20.62	1.812-1P-.2L-DS	(2.093) 53.28	(8.438) 214.32
G	25	C	(1.250) 31.75	(.875) 22.22		(2.093) 53.28	(8.438) 214.32
G	25	D	(1.380) 95.05	(1.000) 25.4		(2.343) 59.51	(8.500) 215.9
H	29	A	(1.188) 30.17	(.812) 20.62	2.000-1P-.2L-DS	(2.093) 53.28	(8.438) 214.32
H	29	B	(1.380) 35.05	(1.000) 25.4		(2.343) 59.51	(8.500) 215.9
J	33	A	(1.380) 35.05	(1.000) 25.4		(2.343) 59.51	(8.500) 215.9
J	33	B	(1.625) 41.27	(1.250) 31.75		(2.750) 69.85	(8.750) 222.25



* Dimensions in (inches) mm

* Dimensions in (inches) mm

M28840/21 RECEPTACLE CONNECTOR WITH STRAIGHT EMI/RFI BACKSHELL

M28840/22 METAL CONDUIT BUSHING

M28840/21	C	G	1	A	A	P	1
DESIGNATION	MATERIAL & FINISH	SHELL SIZE	INSERT	BACK-SHELL SIZE	BACKSHELL STYLE	CONTACT	KEY POSITION
QPL: M28840/21 Commercial: IN28840/21	C: Class DJ; Aluminum Cadmium Plate U: Class ZJ Aluminum -Zinc Nickel, Non-Reflective M: Class TJ; Aluminum Tin Zinc, Non- Reflective (Commercial only)	A: 11 B: 13 C: 15 D: 17 E: 19 F: 23 G: 25 H: 29 J: 33	1	A B C D	A: EMI Environmental B: Environmental	F: Pin, Size 20 G: Socket, Size 20 P: Pin, Size, 22 S: Socket, Size, 22 D: Pin, Size, 28 E: Socket, Size, 28	1 2 3 4 5 6

M28840/22	S	03
DESIGNATION	MATERIAL	DASH #
QPL: M28840/22 Commercial: IN28840/22	S: Corrosion Resistant Steel	03 04 05 06 08 10 12 16

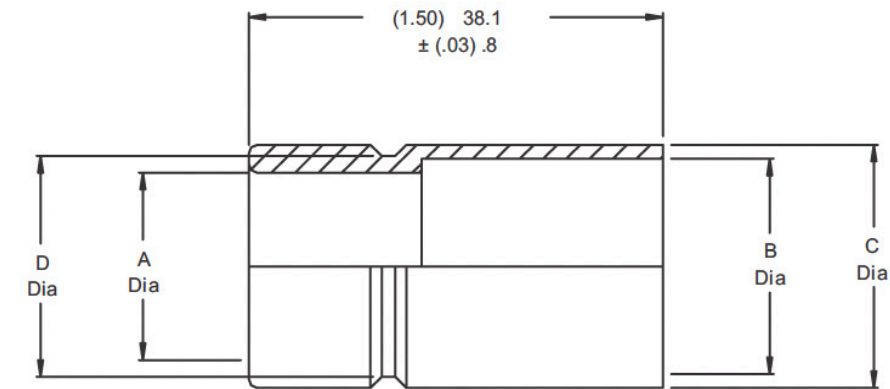
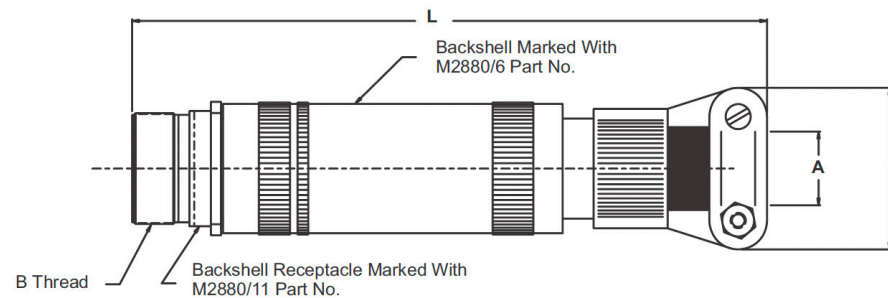

Military Shell Size	Shell Size	Backshell Shell Size	A Cable Entry		B Thread Class 2B	E Max.	L Max.
			Max.	Min.			
A	11	A	(.312) 7.92	(.188) 4.77	.750-1P-.2L-DS	(.938) 23.82	(6.625) 168.27
A	11	B	(.438) 11.12	(.281) 7.13		(1.125) 31.75	(6.625) 168.27
A	11	C	(.562) 14.27	(.344) 8.73		(1.312) 33.32	(6.625) 168.27
B	13	A	(.312) 7.92	(.188) 4.77	.875-1P-.2L-DS	(.938) 23.82	(6.625) 168.27
B	13	B	(.438) 11.12	(.281) 7.13		(1.125) 31.75	(6.625) 168.27
B	13	C	(.562) 14.27	(.344) 8.79		(1.312) 33.32	(6.625) 168.27
B	13	D	(.652) 16.546	(.375) 9.52		(1.312) 33.32	(7.125) 184.15
C	15	A	(.438) 11.12	(.281) 7.13	1.062-1P-.2L-DS	(1.125) 31.75	(6.625) 168.27
C	15	B	(.562) 14.27	(.344) 8.73		(1.312) 33.32	(6.625) 168.27
C	15	C	(.625) 15.87	(.375) 9.52		(1.312) 33.32	(7.125) 180.97
C	15	D	(.750) 19.05	(.438) 11.12		(1.593) 40.46	(7.188) 182.57
C	15	E	(.312) 7.92	(.188) 4.77		(.938) 23.82	(6.625) 168.27
D	17	A	(.625) 16.56	(.375) 9.52	1.125-1P-.2L-DS	(1.312) 33.32	(7.125) 180.97
D	17	B	(.750) 19.05	(.438) 11.12		(1.593) 40.46	(7.188) 182.57
D	17	C	(.938) 23.82	(.625) 15.87		(1.750) 44.45	(7.188) 182.57
E	19	A	(.625) 15.82	(.375) 9.52	1.312-1P-.2L-DS	(1.312) 33.32	(7.125) 180.97
E	19	B	(.938) 23.82	(.625) 15.87		(1.750) 44.45	(7.250) 184.15
F	23	A	(.750) 19.05	(.438) 11.12		1.500-1P-.2L-DS	(1.593) 40.46
F	23	B	(.938) 23.82	(.625) 15.87	(1.750) 44.45		(7.812) 198.42
F	23	C	(1.188) 30.17	(.812) 20.62	(2.093) 53.28		(7.938) 201.62
G	25	A	(.938) 23.82	(.625) 15.87	1.625-1P-.2L-DS	(1.750) 44.45	(7.750) 196.85
G	25	B	(1.188) 30.17	(.812) 20.62		(2.093) 53.28	(8.438) 214.32
G	25	C	(1.250) 31.75	(.875) 22.22		(2.093) 53.28	(8.438) 214.32
G	25	D	(1.380) 95.05	(1.000) 25.4		(2.343) 59.51	(8.500) 215.9
H	29	A	(1.188) 30.17	(.812) 20.62	1.812-1P-.2L-DS	(2.093) 53.28	(8.438) 214.32
H	29	B	(1.380) 35.05	(1.000) 25.4		(2.343) 59.51	(8.500) 215.9
J	33	A	(1.380) 35.05	(1.000) 25.4		2.000-1P-.2L-DS	(2.343) 59.51
J	33	B	(1.625) 41.27	(1.250) 31.75	(2.750) 69.85		(8.750) 222.25

DASH #	MIL-DTL-28840/04 Size Ref.	A ± 0.5 (.02)	B ± 0.12 (.05) †	C ± 0.12 (.05)	D 0.12 (.05)
03	03	(.375) 9.53	(.540) 13.71	(.625) 15.87	(.525) 13.34
04	04	(.500) 12.70	(.665) 16.89	(.750) 19.05	(.650) 16.51
05	05	(.625) 15.87	(.780) 19.81	(.875) 22.23	(.775) 19.69
06	06	(.750) 19.05	(.940) 23.88	(1.000) 25.40	(.900) 22.86
08	08	(1.000) 25.40	(1.225) 31.12	(1.375) 34.93	(1.275) 32.39
10	10	(1.250) 31.75	(1.470) 37.34	(1.625) 41.28	(1.525) 38.74
12	12	(1.500) 38.10	(1.740) 44.20	(1.875) 47.65	(1.775) 45.09
16	16	(2.000) 50.80	(2.215) 56.26	(2.375) 60.33	(2.275) 57.79

* Dimensions in (inches) mm

* Dimensions in (inches) mm



M28840/23 E NUT

M28840/23	J	W
DESIGNATION	SHELL SIZE	MATERIAL & FINISH
QPL: M28840/23 Commercial: IN28840/23	A: 11 B: 13 C: 15 D: 17 E: 19 F: 23 G: 25 H: 29 J: 33	W: Aluminum, Cadmium Plate, O.D. over Electroless Nickel S: Aluminum -Zinc Nickel, Non-Reflective L: Aluminum-Tin-Zinc, Non-Reflective (Commercial only)

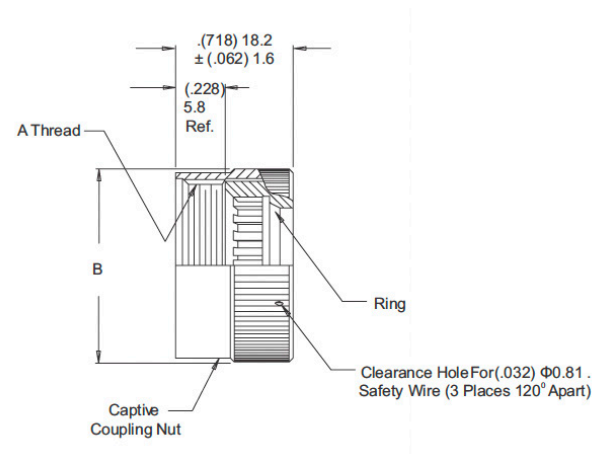

Military Shell Size	Shell Size	A Thread Class 2B	B Ø Max.
A	11	.750-20 UNEF	(1.028) 26.11
B	13	.875-20 UNEF	(1.14) 26.11
C	15	1.000-20 UNEF	(2.263) 32.08
D	17	1.125-18 UNEF	(1.387) 35.23
E	19	1.250-18 UNEF	(1.513) 38.43
F	23	1.438-18 UNEF	(1.703) 43.51
G	25	1.562-18 UNEF	(1.825) 46.35
H	29	1.876-16 UN	(2.143) 54.43
J	33	2.062-16 UNS	(2.329) 59.16

* Dimensions in (inches) mm

M28840/24 MOUNTING GASKET

M28840/24	G	A
DESIGNATION	SHELL SIZE	MATERIAL & FINISH
QPL: M28840/24 Commercial: IN28840/24	A: 11 B: 13 C: 15 D: 17 E: 19 F: 23 G: 25 H: 29 J: 33	A - Fluorinated Silicone B - EMI

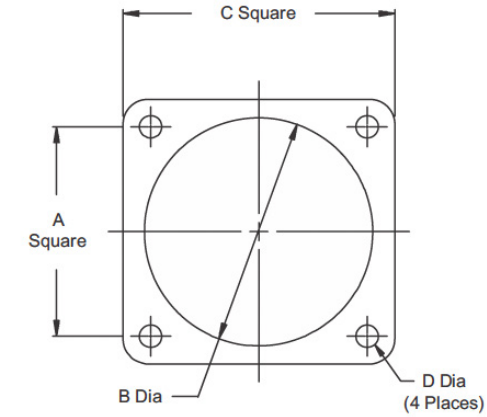

Military Shell Size	Shell Size	A	B Ø	C	D Ø
A	11	(.760) 19.30	(.766) 19.46	(1.039) 26.39	(1.130) 3.30 (1.110) 2.79
		(.740) 18.80	(.750) 19.05	(1.023) 25.98	
B	13	(.853) 21.67	(.891) 22.63	(1.154) 29.31	
		(.833) 21.16	(.875) 22.22	(1.138) 28.90	
C	15	(.978) 24.84	(1.078) 27.38	(1.274) 32.36	
		(.958) 24.33	(1.062) 26.97	(1.258) 31.95	
D	17	(1.025) 26.04	(1.141) 28.98	(1.399) 26.39	
		(1.005) 25.53	(1.125) 28.58	(1.383) 35.13	
E	19	(1.150) 29.21	(1.338) 33.98	(1.524) 38.71	
		(1.130) 28.70	(1.312) 33.32	(1.508) 38.30	
F	23	(1.291) 32.79	(1.516) 38.51	(1.734) 44.04	
		(1.271) 32.28	(1.500) 38.10	(1.718) 43.64	
G	25	(1.402) 35.61	(1.641) 41.68	(1.834) 46.58	(1.157) 3.99 (1.137) 3.48
		(1.382) 35.10	(1.625) 41.28	(1.818) 46.18	
H	29	(1.578) 40.08	(1.891) 48.03	(2.154) 54.71	
		(1.558) 39.57	(1.875) 47.62	(2.138) 54.30	
J	33	(1.744) 44.30	(2.078) 52.78	(2.344) 59.54	(1.183) 4.65 (1.163) 4.14
		(1.724) 43.79	(2.062) 52.37	(2.328) 59.13	

* Dimensions in (inches) mm



M28840/25 90°EMI CONDUIT ADAPTER

M28840/25	16	W	A
DESIGNATION	DASH #	MATERIAL & FINISH	BACKSHELL STYLE
QPL: M28840/25 Commercial: IN28840/25	See Table A	W: Aluminum, Cadmium Plate, O.D. over Electroless Nickel L: Aluminum -Tin-Zinc, Non-Reflective S: Aluminum -Zinc Nickel, Non-Reflective	A: EMI, Non-Environmental B: EMI, Environmental

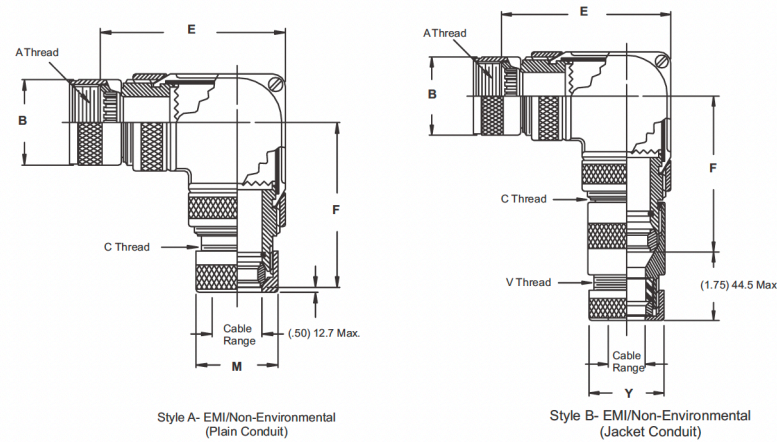

M28840/25 90° EMI CONDUIT ADAPTER

DASH #	Military Shell Size	Conduit Size M28840/4	E Max.	F Max.	V Thread Class 2	M Ø Max.	Y Ø Max.		
01	A	03	(2.36) 59.9	(3.50) 92.8	1.000-20 UNEF	(1.12) 28.5	(1.19) 30.23		
02	B	03			1.000-20 UNEF	(1.12) 28.5	(1.19) 30.23		
03	B	04			1.188-18 UNEF	(1.25) 31.8	(1.38) 35.1		
04	C	03	(2.56) 65.0	(3.69) 97.9	1.000-20 UNEF	(1.12) 28.5	(1.39) 35.3		
05	C	04			1.118-18 UNEF	(1.25) 31.8	(1.38) 35.1		
06	C	05			1.438-18 UNEF	(1.43) 36.3	(1.63) 41.4		
07	C	06	(2.67) 67.8	(3.81) 101.0	1.750-18 UNS	(1.62) 41.2	(1.94) 49.3		
08	D	05			1.438-18 UNEF	(1.43) 36.3	(1.63) 41.4		
09	D	06			1.750-18 UNS	(1.62) 42.2	(1.94) 49.3		
10	D	08			2.00-18 UNS	(1.81) 46.0	(2.19) 55.6		
11	E	05			1.438-18 UNEF	(1.43) 36.3	(1.63) 41.4		
12	E	06			1.750-18 UNS	(1.62) 41.2	(1.94) 49.3		
13	E	08			2.00-18 UNS	(1.81) 46.0	(2.19) 55.6		
14	F	06			(3.05) 77.5	(4.19) 111.1	1.750-18 UNS	(1.62) 41.2	(1.94) 49.3
15	F	08					2.00-18 UNS	(1.81) 46.0	(2.19) 55.6
16	F	10					2.250-18 UN	(2.18) 55.4	(2.44) 62.0
17	G	06	1.750-18 UNS	(1.62) 41.2			(1.94) 49.3		
18	G	08	2.00-18 UN	(1.81) 46.0			(2.19) 55.6		
19	G	10	2.250-18 UN	(2.18) 55.4			(2.44) 62.0		
20	G	12	(3.33) 84.6	(4.50) 119.4	2.500-16 UN	(2.56) 65.0	(2.69) 68.5		
21	H	10			2.250-16 UN	(2.18) 55.4	(2.18) 55.4		
22	H	12			1.500-16 UN	(2.56) 65.0	(2.44) 62.0		
23	J	12	(3.70) 94.0	(4.43) 128.1	2.500-16 UN	(2.56) 65.0	(2.69) 68.3		
24	J	16			3.00-16 UN	(3.06) 77.8	(3.19) 81.0		

DASH #	Military Shell Size	A Thread Class 2B	B Ø Max.	C Thread Class 1	D Ø Max.	Sealing Range	
						Max.	Min.
01	A	.750-20 UNEF	(1.028) 26.11	.875-20 UNEF	(1.031) 26.19	(.63) 16.0	(.50) 12.7
02	B	.875-20 UNEF	(1.141) 28.98	.875-20 UNEF		(.63) 6.0	(.50) 12.7
03	B			1.000-20 UNEF	(.75) 19.1	(.63) 16.0	
04	C	1.000-20 UNEF	(1.263) 32.08	.875-20 UNEF	(.63) 16.0	(.50) 12.7	
05	C			1.000-20 UNEF	(.75) 19.1	(.63) 16.0	
06	C			1.125-18 UNEF	(.88) 22.4	(.75) 19.1	
07	C	1.125-18 UNEF	(1.387) 35.23	1.250-18 UNEF	(1.00) 25.4	(.88) 22.4	
08	D			1.125-18 UNEF	(.88) 22.4	(.75) 19.1	
09	D			1.250-18 UNEF	(1.00) 25.4	(.88) 22.4	
10	D			1.625-18 UNEF	(1.38) 35.1	(1.19) 30.2	
11	E	1.250-18 UNEF	(1.513) 38.43	1.125-18 UNEF	(.88) 22.4	(.75) 19.1	
12	E			1.250-18 UNEF	(1.00) 25.4	(.88) 22.4	
13	E			1.625-18 UNEF	(1.38) 35.1	(1.19) 30.2	
14	F	1.438-18 UNEF	(1.703) 45.51	1.250-18 UNEF	(1.00) 25.4	(0.88) 8 22.4	
15	F			1.625-18 UNEF	(1.38) 35.1	(1.18) 30.2	
16	F			1.875-18 UNS	(1.63) 41.4	(1.44) 36.6	
17	G	1.562-18 UNEF	(1.825) 46.35	1.250-18 UNEF	(1.00) 25.4	(.88) 22.4	
18	G			1.625-18 UNEF	(1.38) 35.1	(1.19) 30.2	
19	G			1.875-18 UNS	(1.63) 41.4	(1.44) 36.5	
20	G			2.125-16 UN	(1.88) 47.8	(1.63) 41.4	
21	H	1.875-16 UN	(2.143) 54.43	1.875-18 UNS	(1.63) 41.4	(1.44) 36.6	
22	H			2.125-16 UN	(1.33) 47.8	(1.63) 41.4	
23	J	2.062-16 UNS	(2.329) 59.16	2.125-16 UN	(1.88) 47.8	(1.63) 41.4	
24	J			2.750-16 UN	(2.38) 60.5	(2.13) 54.1	
25	A	.750-20 UNEF	(1.028) 26.11	.875-20 UNEF	(1.031) 25.19	(.75) 19.5	(.63) 16.0

* Dimensions in (inches) mm

* Dimensions in (inches) mm



M28840/26 PLUG CONNECTOR WITH STRAIGHT EMI/RFI BACKSHELL

M28840/27 45° EMI CONDUIT ADAPTER

M28840/26	C	G	1	A	A	P	1
DESIGNATION	MATERIAL & FINISH	SHELL SIZE	INSERT	BACKSHELL SIZE	BACKSHELL STYLE	CONTACT	KEY POSITION
QPL: M28840/26 Commercial: IN28840/26	C: Class DJ: Aluminum Cadmium Plate U: Class ZJ Aluminum -Zinc Nickel, Non-Reflective M: Class TJ; Aluminum Tin Zinc, Non-Reflective (Commercial only)	A: 11 B: 13 C: 15 D: 17 E: 19 F: 23 G: 25 H: 29 J: 33	1	A B C D	A: EMI Environmental B: Environmental	F: Pin, Size 20 G: Socket, Size 20 P: Pin, Size, 22 S: Socket, Size, 22 D: Pin, Size, 28 E: Socket, Size, 28	1 2 3 4 5 6

M28840/27	16	W	A
DESIGNATION	DASH #	MATERIAL & FINISH	BACKSHELL STYLE
QPL: M28840/27 Commercial: IN28840/27	See Table A	W: Aluminum, Cadmium Plate, O.D. over Electroless Nickel S: Aluminum -Zinc Nickel, Non-Reflective L: Aluminum-Tin-Zinc, Non-Reflective (Commercial only)	A: EMI, Non-Environmental B: EMI, Environmental

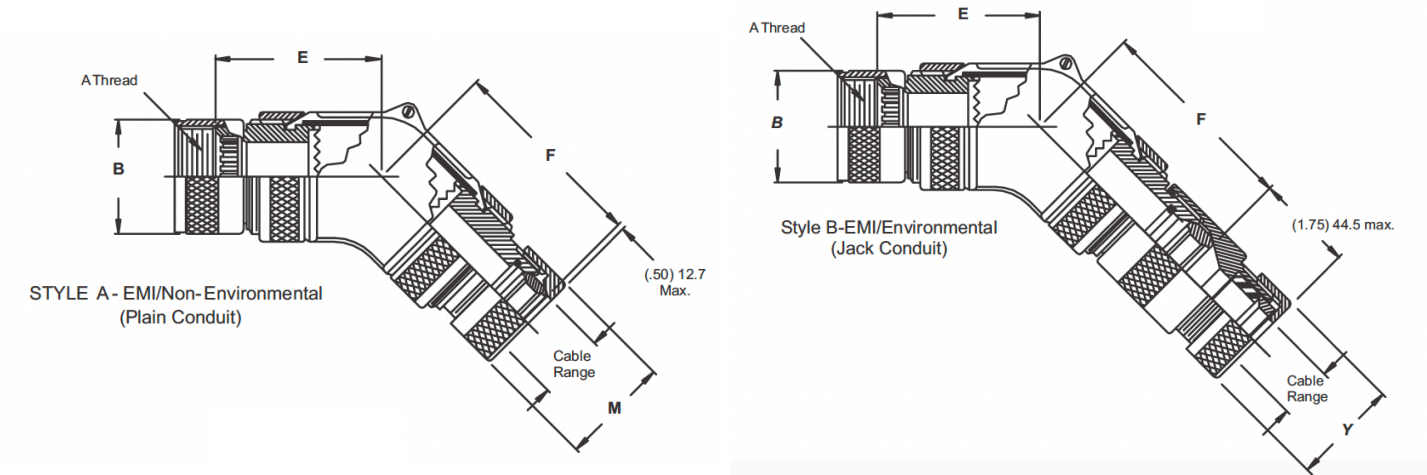
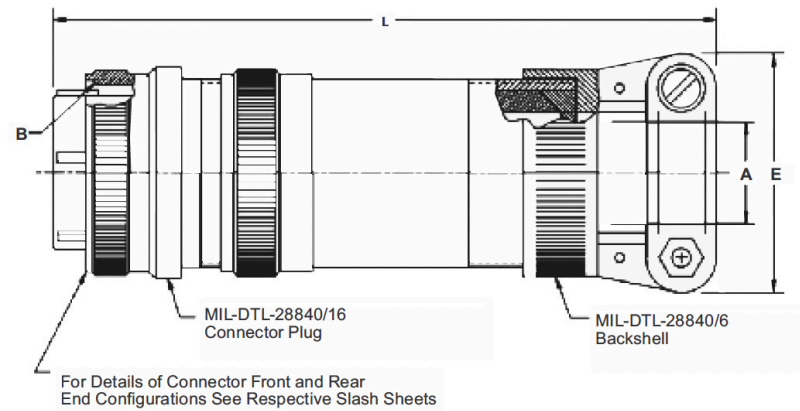

Military Shell Size	Shell Size	Backshell Shell Size	A Cable Entry		B Thread Class 2B	E Max.	L Max.
			Max.	Min.			
A	11	A	(.312) 7.92	(.188) 4.77	.750-1P-.2L-DS	(.938) 23.82	(6.500) 165.1
A	11	B	(.438) 11.12	(.281) 7.13		(1.175) 28.57	(6.500) 165.1
A	11	C	(.562) 14.27	(.344) 8.73		(1.312) 33.32	(6.500) 165.1
B	13	A	(.312) 7.92	(.188) 4.77	.875-1P-.2L-DS	(.938) 23.82	(6.500) 165.1
B	13	B	(.438) 11.12	(.281) 7.13		(1.125) 28.57	(6.500) 165.1
B	13	C	(.562) 14.27	(.344) 8.73		(1.312) 33.32	(6.500) 165.1
B	13	D	(.652) 16.56	(.375) 9.52	1.062-1P-.2L-DS	(1.312) 33.32	(7.000) 177.8
C	15	A	(.438) 11.12	(.281) 7.13		(1.125) 28.57	(6.500) 165.1
C	15	B	(.562) 14.27	(.347) 8.73		(1.312) 33.32	(6.500) 165.1
C	15	C	(.625) 15.87	(.375) 9.52	1.125-1P-.2L-DS	(1.312) 33.32	(6.500) 165.1
C	15	D	(.750) 19.05	(.438) 11.12		(1.593) 40.46	(6.500) 165.1
C	15	E	(.312) 7.92	(.188) 4.77		(0.938) 23.82	(7.000) 177.8
D	17	A	(.625) 15.87	(.375) 9.52	1.312-1P-.2L-DS	(1.312) 33.32	(7.000) 177.8
D	17	B	(.750) 19.05	(.438) 11.12		(1.595) 40.46	(7.000) 177.8
D	17	C	(.938) 23.82	(.625) 15.87		(1.750) 44.45	(7.000) 177.8
E	19	A	(.625) 15.87	(.375) 9.52	1.500-1P-.2L-DS	(1.312) 33.32	(7.500) 190.5
E	19	B	(.938) 23.82	(.625) 15.87		(1.730) 44.15	(7.625) 193.67
F	23	A	(.750) 19.05	(.438) 11.12		(1.593) 40.46	(7.812) 193.42
F	23	B	(.938) 23.82	(.625) 15.87	1.625-1P-.2L-DS	(1.750) 44.45	(7.625) 193.67
F	23	C	(1.188) 30.17	(.812) 20.62		(2.093) 53.16	(7.625) 193.67
G	25	A	(.938) 23.82	(.625) 15.87		(1.750) 44.45	(7.625) 193.67
G	25	B	(1.188) 30.17	(.812) 20.62	1.812-1P-.2L-DS	(2.093) 53.16	(7.625) 193.67
G	25	C	(1.250) 31.75	(.875) 22.22		(2.093) 53.16	(8.312) 211.12
G	25	D	(1.380) 35.05	(1.00) 25.4		(2.343) 59.51	(8.312) 211.12
H	29	A	(1.188) 30.17	(.812) 20.62	2.000-1P-.2L-DS	(2.093) 53.16	(8.312) 211.12
H	29	B	(1.380) 35.05	(1.00) 25.4		(2.343) 59.51	(8.312) 211.12
J	33	A	(1.380) 35.05	(1.00) 25.4		(2.343) 59.51	(8.312) 211.12
J	33	B	(1.625) 41.27	(1.256) 31.75		(2.750) 69.85	(8.625) 219.8

* Dimensions in (inches) mm

DASH #	Military Shell Size	Shell Size	A Thread Class 2B	B Ø Max.	C Thread Class 2	D Ø Max.	Sealing Range		Conduit Size M28840/4	E Max.
							Max..	Min..		
01	A	11	.750-20 UNEF	(1.028) 26.11	.875-20 UNEF	"(1.031) 26.19"	(.63) 16.0	(.50) 12.7	03	(2.36) 59.9
02	B	13	.875-20 UNEF	(1.141) 28.98	.875-20 UNEF		(.63) 16.0	(.50) 12.7	03	
03	B	13			1.000-20 UNEF		(.75) 19.1	(.63) 16.0	04	
04	C	15	1.000-20 UNEF	(1.263) 32.08	.875-20 UNEF	"(1.281) 32.50"	(.63) 16.0	(.50) 12.7	03	(2.56) 65.0
05	C	15			1.000-20 UNEF		(.75) 19.1	(.63) 16.0	04	
06	C	15			1.250-18 UNEF		(.88) 22.4	(.75) 19.1	05	
07	C	15	1.125-18 UNEF	(1.387) 38.23	1.250-18 UNEF	"(1.531) 38.80"	(1.00) 25.4	(.88) 22.4	06	(2.67) 67.8
08	D	17			1.250-18 UNEF		(.88) 22.4	(.75) 19.1	05	
09	D	17			1.625-18 UNEF		(1.00) 25.4	(.88) 22.4	06	
10	D	17	1.250-18 UNEF	(1.513) 38.43	1.625-18 UNEF	"(1.781) 45.24"	(1.38) 35.1	(1.19) 22	08	(3.05) 77.5
11	E	19			1.125-18 UNEF		(.88) 22.4	(.75) 19.1	05	
12	E	19			1.250-18 UNEF		(1.00) 25.4	(.88) 22.4	06	
13	E	19	1.438-18 UNEF	(1.703) 45.51	1.625-18 UNEF	"(1.781) 45.24"	(1.38) 35.1	(1.19) 30.2	08	(3.05) 77.5
14	F	23			1.250-18 UNEF		(1.000) 25.4	(.88) 22.4	06	
15	F	23			1.625-18 UNEF		(1.38) 35.1	(1.19) 30.2	08	
16	F	23	1.562-18 UNEF	(1.825) 46.35	1.875-18 UNS	"(2.031) 51.59"	(1.63) 41.4	(1.44) 36.6	10	(3.33) 84.6
17	G	25			1.250-18 UNEF		(1.00) 25.4	(.88) 22.4	06	
18	G	25			1.625-18 UNEF		(1.38) 41.4	(1.19) 30.2	08	
19	G	25	1.875-16 UNS	(2.143) 54.43	1.875-18 UNS	"(2.531) 64.29"	(1.43) 41.4	(1.44) 36.6	10	(3.70) 94.0
20	G	25			2.125-16 UN		(1.88) 47.8	(1.63) 41.4	12	
21	H	29			1.875-18 UNS		(1.63) 41.4	(1.44) 36.6	10	
22	H	29	2.062-16 UNS	(2.329) 50.16	2.125-16 UN	"(1.031) 26.19"	(1.88) 47.8	(1.63) 41.4	12	(2.36) 59.9
23	J	33			2.750-16 UN		(2.38) 60.5	(2.13) 54.1	16	
24	J	33								
25	A	11	.750-20 UNEF	(1.028) 26.11	.875-20 UNEF	"(1.031) 26.19"	(.75) 19.1	(.63) 16.0	04	(2.36) 59.9

* Dimensions in (inches) mm

M28840/27 45°EMI CONDUIT ADAPTER

TABLE A						
DASH #	Military Shell Size	Shell Size	F Max.	V Thread Class 2	M Ø Max.	Y Ø Max.
01	A	11	(3.50) 88.9	1.000-20 UNEF	(1.12) 28.5	(1.19) 30.23
02	B	13		1.000-20 UNEF	(1.12) 28.5	(1.19) 30.23
03	B	13		1.188-18 UNEF	(1.25) 31.8	(1.38) 35.1
04	C	15	(3.69) 93.7	1.000-20 UNEF	(1.12) 28.5	(1.19) 30.23
05	C	15		1.188-18 UNEF	(1.25) 31.8	(1.38) 35.1
06	C	15		1.438-18 UNEF	(1.43) 36.3	(1.63) 41.4
07	C	15	(3.81) 96.7	1.750-18 UNS	(1.62) 41.2	(1.94) 49.3
08	D	17		1.438-18 UNEF	(1.43) 36.3	(1.63) 41.4
09	D	17		1.750-18 UNS	(1.62) 41.2	(1.94) 49.3
10	D	17		2.00-18 UNS	(1.81) 46.0	(2.19) 55.6
11	E	19		1.438-18 UNEF	(1.43) 36.3	(1.63) 41.4
12	E	19		1.750-18 UNS	(1.62) 41.2	(1.94) 49.3
13	E	19	(4.19) 106.4	2.00-18 UNS	(1.81) 46.0	(2.19) 55.6
14	F	23		1.750-18 UNS	(1.62) 41.2	(1.94) 49.3
15	F	23		2.00-18 UN	(1.81) 46.0	(2.19) 55.6
16	F	23		2.250-16 UN	(2.18) 55.4	(2.44) 62.0
17	G	25		1.750-18 UNS	(1.62) 41.2	(1.94) 49.3
18	G	25		2.00-18 UN	(1.81) 46.0	(2.19) 55.6
19	G	25	(4.50) 114.3	2.250-16 UN	(2.18) 55.4	(2.44) 62.0
20	G	25		2.500-16 UN	(2.56) 65.0	(2.69) 68.3
21	H	29		2.250-16 UN	(2.18) 55.4	(2.44) 62.0
22	H	29	(4.83) 22.6	2.500-16 UN	(2.56) 65.0	(2.69) 68.3
23	J	33		3.00-16 UN	(3.06) 77.8	(3.19) 81.0
24	J	33		2.500-16 UN	(2.56) 65.0	(2.69) 68.3
25	A	11	(3.50) 88.9	1.188-18 UNEF	(1.25) 31.8	(1.38) 35.1

M28840/28 90° ADAPTER ASSEMBLY PLUG

M28840/28	C	G	1	B	A	P	1
DESIGNATION	MATERIAL & FINISH	SHELL SIZE	INSERT	BACKSHELL SIZE	BACKSHELL STYLE	CONTACT	KEY POSITION
QPL: M28840/28 Commercial: IN28840/28	C: Class DJ; Aluminum Cadmium Plate U: Class ZJ Aluminum -Zinc Nickel, Non-Reflective M: Class TJ; Aluminum Tin Zinc, Non-Reflective (Commercial only)	A: 11 B: 13 C: 15 D: 17 E: 19 F: 23 G: 25 H: 29 J: 33	1	A B C D	A: EMI Environmental B: Environmental	F: Pin, Size 20 G: Socket, Size 20 P: Pin, Size, 22 S: Socket, Size, 22 D: Pin, Size, 28 E: Socket, Size, 28	1 2 3 4 5 6

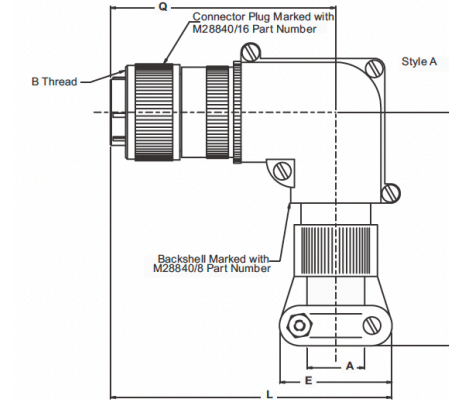

TABLE A									
Military Shell Size	Shell Size	Backshell Shell Size	A Cable Entry		B Thread Class 2B	E Max.	H Max.	L Max.	Q Max.
			Max.	Min.					
A	11	A	(.312) 7.92	(.188) 4.77	.750-1P-.2L-DS	(.938) 23.82	(5.332) 135.43	(3.812) 96.82	(3.250) 82.55
A	11	B	(.438) 11.12	(.281) 7.13		(1.125) 28.57	(5.332) 135.43	(3.812) 96.82	(3.250) 82.55
A	11	C	(.562) 14.27	(.344) 8.73		(1.312) 33.32	(5.457) 138.60	(4.000) 101.6	(3.375) 85.72
B	13	A	(.438) 11.25	(.281) 7.13	.875-1P-.2L-DS	(1.125) 28.57	(5.332) 135.43	(3.812) 96.82	(3.250) 82.55
B	13	B	(.562) 14.27	(.344) 8.73		(1.312) 33.32	(5.457) 138.60	(4.000) 101.6	(3.375) 82.72
B	13	C	(.625) 16.56	(.375) 9.52		(1.312) 33.32	(5.682) 144.32	(4.250) 107.95	(3.500) 88.9
C	15	A	(.438) 11.25	(.281) 7.13	1.062-1P-.2L-DS	(1.125) 28.57	(5.457) 138.60	(4.000) 101.6	(3.375) 85.72
C	15	B	(.562) 14.27	(.344) 8.73		(1.312) 33.32	(5.457) 138.60	(4.000) 101.6	(3.375) 85.72
C	15	C	(.625) 16.56	(.375) 9.52		(1.312) 33.32	(5.682) 144.32	(4.250) 107.95	(3.500) 98.9
C	15	D	(.750) 19.05	(.438) 11.12	1.125-1P-.2L-DS	(1.593) 40.46	(5.713) 145.11	(4.150) 104.77	(3.500) 88.9
D	17	A	(.625) 16.56	(.375) 9.52		(1.312) 33.32	(5.682) 144.32	(4.250) 107.95	(3.500) 88.9
D	17	B	(.750) 19.05	(.438) 11.12		(1.593) 40.46	(5.713) 145.11	(4.250) 107.95	(3.500) 88.9
E	19	A	(.625) 16.56	(.375) 9.52	1.312-1P-.2L-DS	(1.312) 33.32	(5.682) 144.32	(4.250) 107.95	(3.500) 88.9
E	19	B	(.938) 23.82	(.625) 15.87		(1.750) 44.45	(5.832) 148.13	(4.375) 111.12	(3.625) 92.07
F	23	A	(.750) 19.05	(.438) 11.12		(1.593) 40.46	(5.713) 145.11	(4.500) 114.3	(3.625) 92.07
F	23	B	(.938) 23.82	(.625) 15.87	1.500-1P-.2L-DS	(1.750) 44.45	(5.832) 148.13	(4.500) 114.3	(3.625) 92.07
F	23	C	(1.188) 30.17	(.812) 20.62		(2.093) 53.16	(6.019) 152.88	(4.688) 119.07	(3.625) 92.07
G	25	A	(.938) 23.82	(.625) 15.87		(1.750) 44.45	(5.832) 148.13	(4.500) 114.3	(3.625) 92.07
G	25	B	(1.188) 30.17	(.812) 20.62	1.625-1P-.2L-DS	(2.093) 53.16	(6.019) 152.88	(4.688) 119.07	(3.625) 92.07
G	25	C	(1.250) 31.75	(.875) 22.22		(2.093) 53.16	(6.144) 156.05	(4.688) 119.07	(3.750) 95.25
G	25	D	(1.380) 35.05	(1.000) 25.4		(2.343) 59.51	(6.176) 156.87	(4.938) 125.42	(3.750) 95.25
H	29	A	(1.188) 30.17	(.812) 20.62	1.812-1P-.2L-DS	(2.093) 53.16	(6.144) 156.05	(4.812) 122.22	(3.750) 95.25
H	29	B	(1.380) 35.05	(1.000) 25.4		(2.343) 59.51	(6.176) 156.87	(4.938) 125.42	(3.750) 95.25
J	33	A	(1.380) 35.05	(1.000) 25.4		2.000-1P-.2L-DS	(2.343) 59.51	(6.426) 163.22	(5.188) 131.77
J	33	B	(1.625) 41.27	(1.250) 31.75	(2.750) 69.85		(6.701) 170.20	(5.375) 136.52	(4.000) 101.6



* Dimensions in (inches) mm

* Dimensions in (inches) mm

M28840/29 PLUG CONNECTOR WITH 45° EMI/RFI BACKSHELL

M28840/29	C	G	1	b	A	P	1
DESIGNATION	MATERIAL & FINISH	SHELL SIZE	INSERT	BACKSHELL SIZE	BACKSHELL STYLE	CONTACT	KEY POSITION
QPL: M28840/29 Commercial: IN28840/29	C: Class DJ: Aluminum Cadmium Plate U: Class ZJ Aluminum -Zinc Nickel, Non-Reflective M: Class TJ; Aluminum Tin Zinc, Non- Reflective (Commercial only)	A: 11 B: 13 C: 15 D: 17 E: 19 F: 23 G: 25 H: 29 J: 33	1	A B C D	A: EMI Environmental B: Environmental	F: Pin, Size 20 G: Socket, Size 20 P: Pin, Size, 22 S: Socket, Size, 22 D: Pin, Size, 28 E: Socket, Size, 28	1 2 3 4 5 6

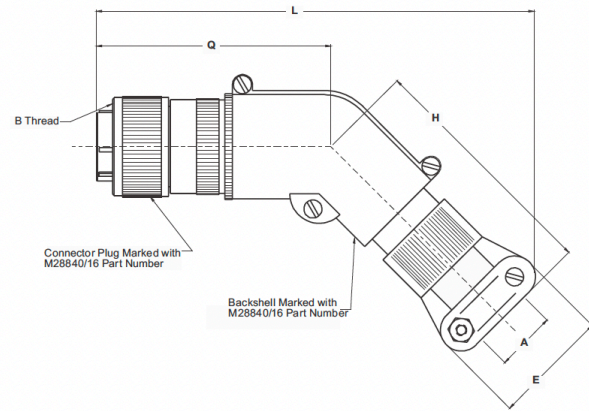

Military Shell Size	Shell Size	Backshell Shell Size	A Cable Entry		B Thread Class 2B	E Max.	H Max.	L Max.	Q Max.
			Max.	Min.					
A	11	A	(.312) 7.92	(.188) 4.77	.750-1P-.2L-DS	(.938) 23.82	(5.332) 135.43	(3.812) 96.82	(3.250) 82.55
A	11	B	(.438) 11.12	(.281) 7.13		(1.125) 28.57	(5.332) 135.43	(3.812) 96.82	(3.250) 82.55
A	11	C	(.562) 14.27	(.344) 8.73		(1.312) 33.32	(5.457) 138.60	(4.000) 101.6	(3.375) 85.72
B	13	A	(.438) 11.25	(.281) 7.13	.875-1P-.2L-DS	(1.125) 28.57	(5.332) 135.43	(3.812) 96.82	(3.250) 82.55
B	13	B	(.562) 14.27	(.344) 8.73		(1.312) 33.32	(5.457) 138.60	(4.000) 101.6	(3.375) 82.72
B	13	C	(.625) 16.56	(.375) 9.52		(1.312) 33.32	(5.682) 144.32	(4.250) 107.95	(3.500) 88.9
C	15	A	(.438) 11.25	(.281) 7.13	1.062-1P-.2L-DS	(1.125) 28.57	(5.457) 138.60	(4.000) 101.6	(3.375) 85.72
C	15	B	(.562) 14.27	(.344) 8.73		(1.312) 33.32	(5.457) 138.60	(4.000) 101.6	(3.375) 85.72
C	15	C	(.625) 16.56	(.375) 9.52		(1.312) 33.32	(5.682) 144.32	(4.250) 107.95	(3.500) 98.9
C	15	D	(.750) 19.05	(.438) 11.12	1.125-1P-.2L-DS	(1.593) 40.46	(5.713) 145.11	(4.150) 104.77	(3.500) 88.9
D	17	A	(.625) 16.56	(.375) 9.52		(1.312) 33.32	(5.682) 144.32	(4.250) 107.95	(3.500) 88.9
D	17	B	(.750) 19.05	(.438) 11.12		(1.593) 40.46	(5.713) 145.11	(4.250) 107.95	(3.500) 88.9
E	19	A	(.625) 16.56	(.375) 9.52	1.312-1P-.2L-DS	(1.312) 33.32	(5.682) 144.32	(4.250) 107.95	(3.500) 88.9
E	19	B	(.938) 23.82	(.625) 15.87		(1.750) 44.45	(5.832) 148.13	(4.375) 111.12	(3.625) 92.07
F	23	A	(.750) 19.05	(.438) 11.12		(1.593) 40.46	(5.713) 145.74	(4.500) 114.3	(3.625) 92.07
F	23	B	(.938) 23.82	(.625) 15.87	1.500-1P-.2L-DS	(1.750) 44.45	(5.832) 148.13	(4.500) 114.3	(3.625) 92.07
F	23	C	(1.188) 30.17	(.812) 20.62		(2.093) 53.16	(6.019) 152.88	(4.688) 119.07	(3.625) 92.07
G	25	A	(.938) 23.82	(.625) 15.87		(1.750) 44.45	(5.832) 148.13	(4.500) 114.3	(3.625) 92.07
G	25	B	(1.188) 30.17	(.812) 20.62	1.625-1P-.2L-DS	(2.093) 53.16	(6.019) 152.88	(4.688) 119.07	(3.625) 92.07
G	25	C	(1.250) 31.75	(.875) 22.22		(2.093) 53.16	(6.144) 156.05	(4.688) 119.07	(3.750) 95.25
G	25	D	(1.380) 35.05	(1.000) 25.4		(2.343) 59.51	(6.176) 156.87	(4.938) 125.42	(3.750) 95.25
H	29	A	(1.188) 30.17	(.812) 20.62	1.812-1P-.2L-DS	(2.093) 53.16	(6.144) 156.05	(4.812) 122.22	(3.750) 95.25
H	29	B	(1.380) 35.05	(1.000) 25.4		(2.343) 59.51	(6.176) 156.87	(4.938) 125.42	(3.750) 95.25
J	33	A	(1.380) 35.05	(1.000) 25.4		(2.343) 59.51	(6.426) 163.22	(5.188) 131.77	(4.000) 101.6
J	33	B	(1.625) 41.27	(1.250) 31.75	2.000-1P-.2L-DS	(2.750) 69.85	(6.701) 170.20	(5.375) 136.52	(4.000) 101.6

* Dimensions in (inches) mm

M28840/30 METAL CONDUIT COUPLER STYLES A & B

M28840/30	16	W	A
DESIGNATION	DASH #	MATERIAL & FINISH	BACKSHELL STYLE
QPL: M28840/30 Commercial: IN28840/30	See Table A	W: Aluminum, Cadmium Plate, O.D. over Electroless Nickel	A: EMI, Non-Environmental B: Environmental

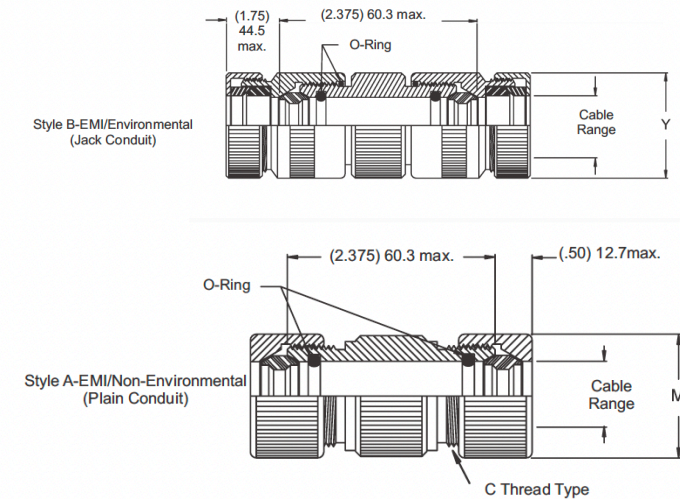

DASH #	Conduit Size	Sealing Range		C Thread	M Ø Max.	V Thread Class 2	Y Ø Max.
		Min.	Max.				
03	03	(.50) 12.7	(.63) 16.0	.875-20 UNEF	(1.12) 28.5	.100-20 UNEF	(1.19) 30.23
04	04	(.63) 16.0	(.75) 19.1	1.000-20 UNEF	(1.25) 31.8	1.188-18 UNEF	(1.38) 35.1
05	05	(.75) 18.1	(.88) 22.4	1.125-18 UNEF	(1.43) 36.3	1.438-18 UNEF	(1.63) 41.4
06	06	(.88) 22.4	(1.00) 25.4	1.250-18 UNEF	(1.62) 41.2	1.750-18 UNS	(1.94) 49.3
08	08	(1.19) 30.2	(1.38) 35.1	1.625-18 UNEF	(1.81) 46.0	2.00-18 UNS	(2.19) 55.6
10	10	(1.44) 36.6	(1.63) 41.4	1.875-18 UNS	(2.18) 55.4	2.250-16 UN	(2.44) 62.0
12	12	(1.63) 41.4	(1.88) 47.8	2.125-16 UN	(2.56) 65.0	2.50-16 UN	(2.69) 68.3
16	16	(2.13) 54.1	(2.38) 60.5	2.750-16 UN	(3.06) 77.8	3.00-16 UN	(3.19) 81.0



www.powell.com
800-235-7880
pcinfo@powell.com

* Dimensions in (inches) mm

M39029/83 STANDARD DUTY ELECTRICAL PIN CONTACT

Standard Pin Crimp Contact for MIL-DTL-28840 Connectors

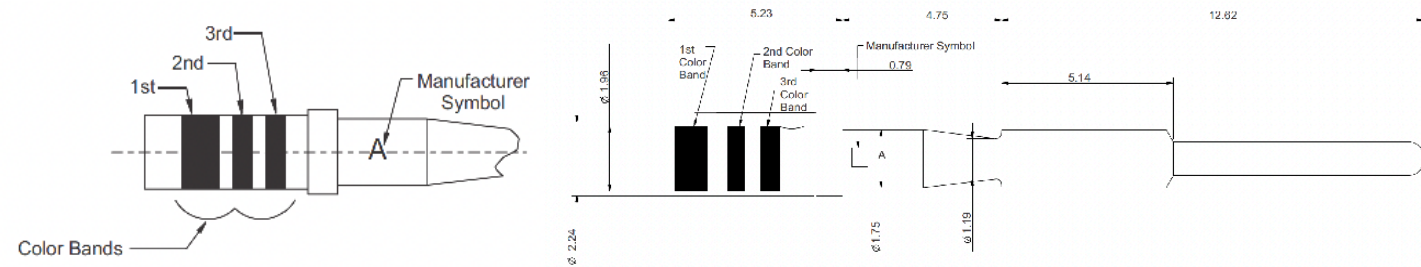

Mating End Size	Wire Accomodation	Military P/N	Amphenol P/N
20	20-24 AWG	M39029 /83-508	IN39029/83-508
20	22-26 AWG	M39029 /83-450	IN39029/83-450
20	28-32 AWG	M39029 /83-451	IN39029/83-451

Materials & Finish

Pin Contact: Copper Alloy per ASTM B197, 50 Micro inches Gold plated per ASTM B488 Type II Code C Class 1. 27 over nickel plate per QQ-N-290 Class 2, 50-100 micro inches.

Size	Military P/N	Amphenol P/N	B Ø	C Ø	Color Bands		
					1st	2nd	3rd
20	M39029 /83-508	IN39029/83-508	(.050) 1.27 (.048) 1.21	(.032) 0.81 (.26) 0.66	Green	Black	Grey
20	M39029 /83-450	IN39029/83-450	(.0355) 0.91 (.0355) 0.86	(.032) 0.81 (.026) 0.66	Yellow	Green	Black
20	M39029 /83-451	IN39029/83-451	(.0200) 0.50 (.0180) 0.45	(.022) 0.56 (.018) 0.46	Yellow	Green	Brown

Size	Military P/N	Amphenol P/N	AWG Handling	Crimp Tool	Positioner	Insertion Tool	Extraction Tool
20	M39029 /83-508	IN39029/83-508	20, 22, 24	M22520/34-01	M22520/34-02	M81969/33-01	M81969/34-01
20	M39029 /83-450	IN39029/83-450	22, 24, 26	M22520/34-01	M22520/34-02	M81969/33-01	M81969/34-01
20	M39029 /83-451	IN39029/83-451	28, 30, 32	M22520/34-01	M22520/34-02	M81969/33-01	M81969/34-01

Size	Military P/N
Durability	(Meets SAE-AS39029, paragraph 3.5.9) No electrical or mechanical defects after 500 cycles of engagement & disengagement
Contact Retention	(Meets MIL-DTL-38999, paragraph 3.23) The axial displacement of the contact shall not exceed .012 inch (0.30 mm). No damage to contacts or inserts shall result.
Pin Engagement End	(Meets SAE-AS39029 paragraph 3.4.1) Unless otherwise specified, the mating end of all contacts (except size 22 and smaller) shall be formed with an approximate spherical radius.
Permeability	(Meets SAE-AS39029, paragraph 3.5.1) When tested as specified in paragraph 4.7.2, the relative magnetic permeability of the contact shall be no greater than 2.0.
Vibration	(Meets SAE-AS39029, paragraph 3.5.10) When contacts are tested as specified in paragraph 4.7.11, there shall be no electrical discontinuity of 1 microsecond or greater. There shall be no defects detrimental to the mechanical or electrical performance.
Salt Spray (corrosion)	(Meets SAE-AS39029, paragraph 3.5.12) When tested as specified in 4.7.13. mated contacts shall withstand 48 hours of salt spray conditioning without defects detrimental to the mechanical or electrical performance.
Temperature life	(Meets SAE-AS39029, paragraph 3.5.13) When tested as specified in paragraph 4. 7. 14, mated contacts shall withstand temperature conditioning for 1,000 hours without defects detrimental to mechanical or electrical performance. There shall be no diffusion/migration of the base metal through the contact outer plating Class A - Maximum operating temperature +125°C. per paragraph 1.2.2
Dielectric withstanding voltage	(Meets SAE-AS39029, paragraph 3.5.19) When tested as specified in paragraph 4.7.20, crimped contacts shall show no evidence of breakdown or flashover.
Workmanship	(Meets SAE-AS39029, paragraph 3.7) Contacts shall be processed in such a manner as to be uniform in quality and shall be free from foreign material & burrs or sharp corners that might damage the connector or affect mating of the contacts. Burrs & sharp edges shall be removed 0.005 inch max. (0.13mm)

M39029/84 STANDARD DUTY ELECTRICAL SOCKET CONTACT

Standard Socket Crimp Contact for MIL-DTL-28840 Connectors

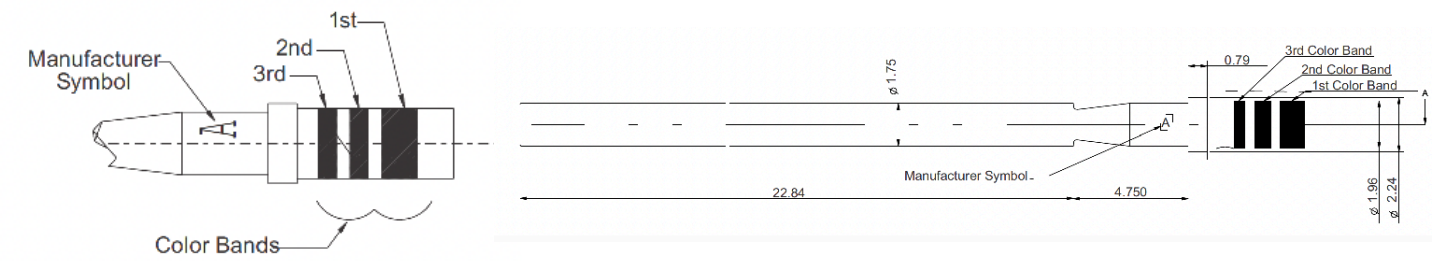

Mating End Size	Wire Accomodation	Military P/N	Amphenol P/N
20	20-24 AWG	M39029/84-509	IN39029/84-509
20	22-26 AWG	M39029/84-452	IN39029/84-452
20	28-32 AWG	M39029/84-453	IN39029/84-453

Materials & Finish

Pin Contact: Copper Alloy per ASTM B197, 50 Micro inches Gold plated per ASTM B488 Type II Code C Class 1. 27 over nickel plate per QQ-N-290 Class 2, 50-100 micro inches.
Socket Contact Hood: Stainless Steel, passivated per AMS-QQ-P-35.

Size	Military P/N	Amphenol P/N	B Ø	C Ø	Color Bands		
					1st	2nd	3rd
20	M39029/84-509	IN39029/84-509	(.050) 1.27 (.048) 1.21	(.032) 0.81 (.026) 0.66	Green	Black	White
20	M39029/84-452	IN39029/84-452	(.0355) 0.91 (.0335) 0.86	(.032) 0.81 (.026) 0.66	Yellow	Green	Red
20	M39029/84-453	IN39029/84-453	(.0200) 0.52 (.0180) 0.45	(.022) 0.56 (.018) 0.45	Yellow	Green	Orange

Size	Military P/N	Amphenol P/N	AWG Handling	Crimp Tool	Positioner	Insertion Tool	Extraction Tool
20	M39029/84-509	IN39029/84-509	20, 22, 24	M22520/34-01	M22520/34-02	M81969/33-01	M81969/34-01
20	M39029/84-452	IN39029/84-452	22, 24, 26	M22520/34-01	M22520/34-02	M81969/33-01	M81969/34-01
20	M39029/84-453	IN39029/84-453	28, 30, 32	M22520/34-01	M22520/34-02	M81969/33-01	M81969/34-01

Size	Military P/N
Durability	(Meets SAE-AS39029, paragraph 3.5.9) No electrical or mechanical defects after 500 cycles of engagement & disengagement
Contact Retention	(Meets MIL-DTL-38999, paragraph 3.23) The axial displacement of the contact shall not exceed .012 inch (0.30 mm). No damage to contacts or inserts shall result.
Pin Engagement End	(Meets SAE-AS39029 paragraph 3.4.1) Unless otherwise specified, the mating end of all contacts (except size 22 and smaller) shall be formed with an approximate spherical radius.
Permeability	(Meets SAE-AS39029, paragraph 3.5.1) When tested as specified in paragraph 4.7.2, the relative magnetic permeability of the contact shall be no greater than 2.0.
Vibration	(Meets SAE-AS39029, paragraph 3.5.10) When contacts are tested as specified in paragraph 4.7.11, there shall be no electrical discontinuity of 1 microsecond or greater. There shall be no defects detrimental to the mechanical or electrical performance.
Salt Spray (corrosion)	(Meets SAE-AS39029, paragraph 3.5.12) When tested as specified in 4.7.13. mated contacts shall withstand 48 hours of salt spray conditioning without defects detrimental to the mechanical or electrical performance.
Temperature life	(Meets SAE-AS39029, paragraph 3.5.13) When tested as specified in paragraph 4. 7. 14, mated contacts shall withstand temperature conditioning for 1,000 hours without defects detrimental to mechanical or electrical performance. There shall be no diffusion/migration of the base metal through the contact outer plating Class A - Maximum operating temperature +125°C. per paragraph 1.2.2
Dielectric withstanding voltage	(Meets SAE-AS39029, paragraph 3.5.19) When tested as specified in paragraph 4.7.20, crimped contacts shall show no evidence of breakdown or flashover.
Workmanship	(Meets SAE-AS39029, paragraph 3.7) Contacts shall be processed in such a manner as to be uniform in quality and shall be free from foreign material & burrs or sharp corners that might damage the connector or affect mating of the contacts. Burrs & sharp edges shall be removed 0.005 inch max. (0.13mm)

MIL-DTL-28840 POLARIZATION KEYWAYS/PANEL CUT OUT

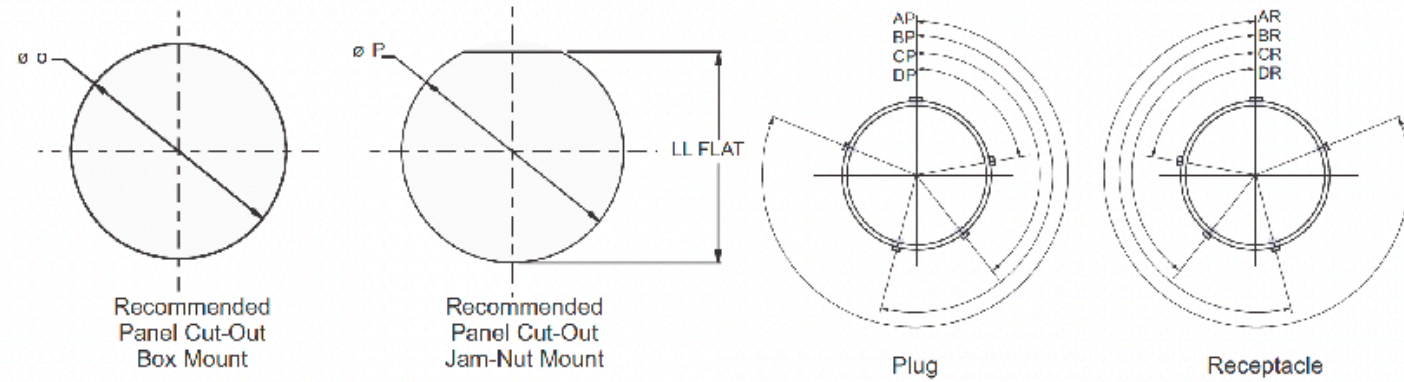

Military Shell Size	Shell Size	P Ø	LL Flat	Ø Ref. Mating Hole
A	11	(.890) 22.60 (.880) 22.25	(.853) 21.67 (.843) 21.41	(.812) 20.62
B	13	(1.015) 25.78 (1.005) 25.53	(.978) 24.84 (.968) 24.59	(.937) 23.80
C	15	(1.203) 30.55 (1.193) 30.3	(1.165) 29.59 (1.155) 29.34	(1.124) 28.55
D	17	(1.265) 32.13 (1.255) 25.40	(1.228) 31.19 (1.218) 30.94	(1.187) 30.15
E	19	(1.453) 36.91 (1.443) 36.65	(1.415) 35.94 (1.405) 35.69	(1.374) 34.90
F	23	(1.640) 41.66 (1.630) 41.40	(1.603) 40.72 (1.593) 40.46	(1.562) 39.67
G	25	(1.765) 44.83 (1.755) 44.57	(1.728) 43.89 (1.718) 43.64	(1.687) 42.85
H	29	(1.953) 49.60 (1.943) 49.35	(1.915) 48.64 (1.905) 48.38	(1.874) 47.60
J	33	(2.140) 54.36 (2.130) 54.10	(2.103) 53.42 (2.093) 53.16	(2.062) 52.37

Military Shell Size	Shell Size	Key & Keyway Arrangement	AR ^o or AP ^o BSC	BR ^o or BP ^o BSC	CR ^o or CP ^o BSC	DR ^o or DP ^o BSC
A B	11 13	1	95	141	208	236
		2	113	156	182	292
		3	90	145	195	252
		4	53	156	220	255
		5	119	146	176	298
		6	51	141	184	242
C D	15 17	1	80	142	196	293
		2	135	170	200	310
		3	49	169	200	244
		4	66	140	200	257
		5	62	145	180	280
		6	79	153	197	272
E F G H J	19 23 25 29 33	1	80	142	196	293
		2	135	170	200	310
		3	49	169	200	244
		4	66	140	200	257
		5	62	145	180	280
		6	79	153	197	272

CONTACT INSERTION/EXTRACTION INSTRUCTIONS

1. Tools

Be sure that all proper assembly tools are on hand & properly calibrated.



2. Stripping

Strip wire inds to 3/16" for 20-32 AWG, taking care not to nick or cut wire strands. Hold insulation & twist strands to eliminate any splaying.

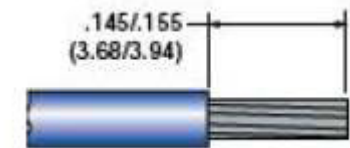

3. Wire Insertion

Insert wire into crimp well of contact. Don't force. Wire strands must be visible through inspection hole.

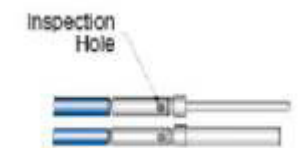

4. Crimping

Using crimp tool & positioner noted above insert wire & contact into locator jaws. Squeeze tool handle completely until ratchet releases. Remove wired contact from tool (Pic. 4).



5. Backshell Preparation

Slide backshell/strain relief over jacketed cable or wires in proper order for re-assembly. Contact factory for proper jacketed cable assembly.



6. Contact Preparation

Slide wired contact into insertion tool of choice so that the tip of the tool butts against the shoulder of the contact.



CONTACT INSERTION/EXTRACTION INSTRUCTIONS

1. Insertion of Contacts

1. Insertion of Contacts: Insert wired contacts & tool into contact 'clicks' into retention clip A straight pull on the wire will assure the contact is properly seated. Note: Isopropyl alcohol maybe used sparingly as a lubricant.

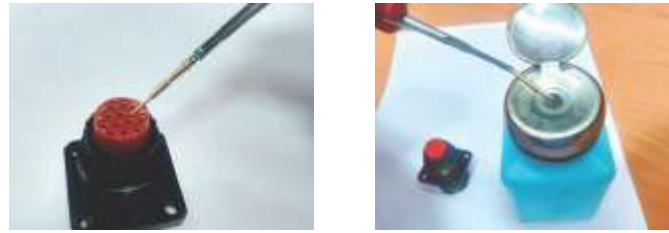

2. Assembly

After all contacts are inserted, assemble backshell or strain relief according to Amphenol backshell catalog instructions.

1. Contact Extraction

Remove backshell or strain relief from connector.



2. Contact Extraction

MIL-DTL-28840 connector contacts are extracted from the rear but released from the front of the connector. Using an extraction tool, slide tool tip into front of contact cavity (Mating face of connector, until tool tip engages against contact retention clip. Push plunger with min. force to release contact. Note: Isopropyl alcohol may be used sparingly as a lubricant.



3. Contact Extraction

Pull wired contact from rear grommet of connector.

Contact Replacement

After replacing contact re-insert starting with assembly instructions number 7.

CONTACT CRIMPING, INSERTION, REMOVAL TOOLS

M22520/34-01 Basic Crimp Tool

Qualified to M22520/34-01, this crimp tool prevents improper crimps and over crimping and is based on the AFM8 miniature adjustable crimp tool, it performs a modified eight impression crimp with a precision cycle controlled ratcheting mechanism for gas-tight wire terminations and excellent tensile strength. Also featured is a four-step crimp depth selector knob and is designed for use with the M22520/34-02 bayonet-type Positioner. Gaging is accomplished with the M22520/35 "Go/No-Go" Gage. The adjustment wheel has eight settings. Check calibration with the M22520/35 gage. Length is 6.75 inches, weight is approximately 10oz.



M22520/34-02 Positioner

This bayonet type positioned locates and holds contacts at the correct position for crimping with the M22520/34-01 Basic Crimp Tool. The face plate shows the correct tool settings. The face plate shows the correct tool settings.



M22520/35 Gauge

Periodic Gauging is recommended to ensure accurate calibration and is easily accomplished by setting the tool selector knob to the proper position and checking the indenter closure with the M22520/35 "Go/No-Go" Gauge.



M22520/34-01 Basic Crimp Tool

Qualified to M22520/34-01, this crimp tool prevents improper crimps and over crimping and is based on the AFM8 miniature adjustable crimp tool, it performs a modified eight impression crimp with a precision cycle controlled ratcheting mechanism for gas-tight wire terminations and excellent tensile strength. Also featured is a four-step crimp depth selector knob and is designed for use with the M22520/34-02 bayonet-type Positioner. Gaging is accomplished with the M22520/35 "Go/No-Go" Gage. The adjustment wheel has eight settings. Check calibration with the M22520/35 gage. Length is 6.75 inches, weight is approximately 10oz.



M22520/34-02 Positioner

This bayonet type positioned locates and holds contacts at the correct position for crimping with the M22520/34-01 Basic Crimp Tool. The face plate shows the correct tool settings. The face plate shows the correct tool settings.



M22520/35 Gauge

Periodic Gauging is recommended to ensure accurate calibration and is easily accomplished by setting the tool selector knob to the proper position and checking the indenter closure with the M22520/35 "Go/No-Go" Gauge.





www.powell.com



800-235-7880



pcdinfo@powell.com

Amphenol Pcd

www.amphenolpcd.com